

CEFEPIME- cefepime injection, powder, for solution

SAMSON MEDICAL TECHNOLOGIES LLC

HIGHLIGHTS OF PRESCRIBING INFORMATION

These highlights do not include all the information needed to use CEFEPIME FOR INJECTION safely and effectively. See full prescribing information for CEFEPIME FOR INJECTION.

CEFEPIME for Injection, for intravenous use

PHARMACY BULK PACKAGE - NOT FOR DIRECT INFUSION

Initial U.S. Approval: 1996

INDICATIONS AND USAGE

Cefepime for Injection, USP is a cephalosporin antibacterial indicated for the treatment of the following infections caused by susceptible strains of the designated microorganisms:

- Pneumonia. (1.1)
- Empiric therapy for febrile neutropenic patients. (1.2)
- Uncomplicated and complicated urinary tract infections (including pyelonephritis). (1.3)
- Uncomplicated skin and skin structure infections. (1.4)
- Complicated intra-abdominal infections (used in combination with metronidazole) in adults. (1.5)

To reduce the development of drug-resistant bacteria and maintain the effectiveness of cefepime and other antibacterial drugs, cefepime should be used only to treat infections that are proven or strongly suspected to be caused by bacteria. (1.6)

DOSAGE AND ADMINISTRATION

For intravenous use only over approximately 30 minutes (2)

THIS IS A PHARMACY BULK PACKAGE - NOT FOR DIRECT INJECTION. Cefepime for Injection, Pharmacy Bulk Package bag SmartPak should not be used in patients who require less than a 500 mg dose of cefepime.

Recommended Dosage in Adults with Creatinine Clearance (CrCL) Greater Than 60 mL/min (2.1)			
Site and Type of Infection	Dose	Frequency	Duration (days)
Moderate to Severe Pneumonia [§]	1 to 2 g IV	Every 8 to 12 hours	10
Empiric Therapy for Febrile Neutropenic Patients	2 g IV	Every 8 hours	7*
Mild to Moderate Uncomplicated or Complicated Urinary Tract Infections	0.5 to 1 g IV/IM**	Every 12 hours	7 to 10
Severe Uncomplicated or Complicated Urinary Tract Infections	2 g IV	Every 12 hours	10
Moderate to Severe Uncomplicated Skin and Skin Structure Infections	2 g IV	Every 12 hours	10
Complicated Intra-abdominal Infections [§] (used in combination with metronidazole)	2 g IV	Every 12 hours	7 to 10

[§]For *Pseudomonas aeruginosa*, use 2 g IV every 8 hours. (2.1)

*Or until resolution of neutropenia. (2.1)

**Intramuscular route of administration is indicated only for mild to moderate, uncomplicated or complicated UTIs due to *E. coli*. (2.1)

Pediatric Patients (2 months to 16 years)

Recommended dosage in pediatric patients with CrCL greater than 60 mL/min. (2.2)

- The usual recommended dosage in pediatric patients is 50 mg per kg per dose administered every 12 hours (every 8 hours for febrile neutropenia). (2.2)
- Patients with Renal Impairment: Adjust dose in patients with CrCL less than or equal to 60 mL/min. (2.3)

DOSAGE FORMS AND STRENGTHS

Cefepime for Injection, USP, is a sterile powder available as Pharmacy Bulk Package bags, 100 grams (3)

THIS IS A PHARMACY BULK PACKAGE – NOT FOR DIRECT INJECTION

-----**CONTRAINDICATIONS**-----

Patients with known immediate hypersensitivity reactions to cefepime or other cephalosporins, penicillins or other beta-lactam antibacterial drugs. (4)

-----**WARNINGS AND PRECAUTIONS**-----

- **Hypersensitivity Reactions:** Cross-hypersensitivity among beta-lactam antibacterial drugs may occur in up to 10% of patients with a history of penicillin allergy. If an allergic reaction to Cefepime for Injection occurs, discontinue the drug. (5.1)
- **Neurotoxicity:** May occur especially in patients with renal impairment administered unadjusted doses. If neurotoxicity associated with cefepime occurs, discontinue the drug. (5.2)
- ***Clostridium difficile* Associated Diarrhea (CDAD):** Evaluate if diarrhea occurs. (5.3)

-----**ADVERSE REACTIONS**-----

- The most common adverse reactions (incidence \geq 1%) were local reactions, positive Coombs test, decreased phosphorous, increased ALT and AST, increased PT and PTT and rash. (6.1)
- At the highest dose (2 g every 8 hours), incidence of adverse reactions was \geq 1% for rash, diarrhea, nausea, vomiting, pruritus, fever, and headache. (6.1)

To report SUSPECTED ADVERSE REACTIONS, contact Samson Medical Technologies, L.L.C. at 1-877-418-3600 or FDA at 1-800-FDA-1088 or www.fda.gov/medwatch

-----**DRUG INTERACTIONS**-----

- **Aminoglycosides:** increased potential of nephrotoxicity and ototoxicity. Monitor renal function. (7.2)
- **Diuretics:** nephrotoxicity has been reported following concomitant administration of other cephalosporins with potent diuretics such as furosemide. Monitor renal function. (7.3)

-----**USE IN SPECIFIC POPULATIONS**-----

- **Geriatric Use:** Serious neurologic adverse reactions have occurred in geriatric patients with renal insufficiency given unadjusted doses of cefepime. (8.5)
- **Pediatric Use: Cefepime for Injection - Pharmacy Bulk Package bag, SmartPak® should not be used in pediatric patients requiring less than a 500 mg dose of cefepime.**
- **Renal Impairment: Cefepime for Injection - Pharmacy Bulk Package bag, SmartPak® should not be used in renally impaired patients who require less than a 500 mg dose of cefepime.**

See 17 for PATIENT COUNSELING INFORMATION.

Revised: 12/2019

FULL PRESCRIBING INFORMATION: CONTENTS*

1 INDICATIONS AND USAGE

- 1.1 Pneumonia
- 1.2 Empiric Therapy for Febrile Neutropenic Patients
- 1.3 Uncomplicated and Complicated Urinary Tract Infections (including pyelonephritis)
- 1.4 Uncomplicated Skin and Skin Structure Infections
- 1.5 Complicated Intra-abdominal Infections (used in combination with metronidazole)
- 1.6 Usage

2 DOSAGE AND ADMINISTRATION

- 2.1 Dosage for Adults
- 2.2 Pediatric Patients (2 months up to 16 years)
- 2.3 Dosage Adjustments in Patients with Renal Impairment
- 2.4 Preparation for Use of Cefepime for Injection, USP, Pharmacy Bulk Package bags, SmartPak®

3 DOSAGE FORMS AND STRENGTHS

4 CONTRAINDICATIONS

5 WARNINGS AND PRECAUTIONS

- 5.1 Hypersensitivity Reactions
- 5.2 Neurotoxicity
- 5.3 *Clostridium difficile* Associated Diarrhea
- 5.4 Development of Drug-Resistant Bacteria
- 5.5 Drug/Laboratory Test Interactions

6 ADVERSE REACTIONS

- 6.1 Clinical Trials Experience
- 6.2 Postmarketing Experience
- 6.3 Cephalosporin-Class Adverse Reactions

7 DRUG INTERACTIONS

- 7.1 Drug/Laboratory Test Interactions
- 7.2 Aminoglycosides
- 7.3 Diuretics

8 USE IN SPECIFIC POPULATIONS

- 8.1 Pregnancy
- 8.2 Labor and Delivery
- 8.3 Nursing Mothers
- 8.4 Pediatric Use
- 8.5 Geriatric Use
- 8.6 Renal Impairment

10 OVERDOSAGE

11 DESCRIPTION

12 CLINICAL PHARMACOLOGY

- 12.1 Mechanism of Action
- 12.2 Pharmacodynamics
- 12.3 Pharmacokinetics
- 12.3 Pharmacokinetics
- 12.4 Microbiology

13 NONCLINICAL TOXICOLOGY

- 13.1 Carcinogenesis, Mutagenesis, Impairment of Fertility

14 CLINICAL STUDIES

- 14.1 Febrile Neutropenic Patients
- 14.2 Complicated Intra-abdominal Infections

15 REFERENCES

16 HOW SUPPLIED/STORAGE AND HANDLING

17 PATIENT COUNSELING INFORMATION

* Sections or subsections omitted from the full prescribing information are not listed.

FULL PRESCRIBING INFORMATION

1 INDICATIONS AND USAGE

1.1 Pneumonia

Cefepime is indicated in the treatment of pneumonia (moderate to severe) caused by susceptible strains of *Streptococcus pneumoniae*, including cases associated with concurrent bacteremia, *Pseudomonas aeruginosa*, *Klebsiella pneumoniae*, or *Enterobacter* species.

1.2 Empiric Therapy for Febrile Neutropenic Patients

Cefepime as monotherapy is indicated for empiric treatment of febrile neutropenic patients. In patients at high risk for severe infection (including patients with a history of recent bone marrow transplantation, with hypotension at presentation, with an underlying hematologic malignancy, or with severe or prolonged neutropenia), antimicrobial monotherapy may not be appropriate. Insufficient data exist to support the efficacy of cefepime monotherapy in such patients. [see *Clinical Studies (14.1)*].

1.3 Uncomplicated and Complicated Urinary Tract Infections (including pyelonephritis)

Cefepime is indicated in the treatment of uncomplicated and complicated urinary tract infections (including pyelonephritis) caused by susceptible isolates of *Escherichia coli* or *Klebsiella pneumoniae*, when the infection is severe, or caused by *Escherichia coli*, *Klebsiella pneumoniae*, or *Proteus mirabilis*, when the infection is mild to moderate, including cases associated with concurrent bacteremia with these bacteria.

1.4 Uncomplicated Skin and Skin Structure Infections

Cefepime is indicated in the treatment of uncomplicated skin and skin structure infections caused by *Staphylococcus aureus* (methicillin-susceptible isolates only) or *Streptococcus pyogenes*.

1.5 Complicated Intra-abdominal Infections (used in combination with metronidazole)

Cefepime is indicated in the treatment of complicated intra-abdominal infections (used in combination with metronidazole) in adults caused by susceptible isolates of *Escherichia coli*, viridans group streptococci, *Pseudomonas aeruginosa*, *Klebsiella pneumoniae*, *Enterobacter* species or *Bacteroides fragilis*. [see *Clinical Studies (14.2)*].

1.6 Usage

To reduce the development of drug-resistant bacteria and maintain the effectiveness of Cefepime for Injection, USP and other antibacterial drugs, Cefepime for Injection, USP should be used only to treat infections that are proven or strongly suspected to be caused by susceptible bacteria. When culture and susceptibility information are available, they should be considered in selecting or modifying antibacterial therapy. In the absence of such data, local epidemiology and susceptibility patterns may contribute to the empiric selection of therapy.

2 DOSAGE AND ADMINISTRATION

THE INTENT OF THIS PHARMACY BULK PACKAGE IS FOR THE PREPARATION OF SOLUTIONS FOR INTRAVENOUS INFUSION ONLY. BEFORE ADMINISTRATION, THIS PHARMACY BULK PACKAGE REQUIRES RECONSTITUTION TO A

CONCENTRATION OF 100 mg/mL AND FURTHER DILUTION IN 50 mL OF A COMPATIBLE SOLUTION.

THIS IS A PHARMACY BULK PACKAGE - NOT FOR DIRECT INJECTION

2.1 Dosage for Adults

Cefepime for Injection, Pharmacy Bulk Package bag SmartPak® should not be used in patients who require less than a 500 mg dose of cefepime.

The recommended adult dosages and routes of administration are outlined Table 1 below for patients with creatinine clearance greater than 60 mL/min. Administer Cefepime for Injection, USP intravenously over approximately 30 minutes.

Table 1: Recommended Dosage Schedule for Cefepime for Injection, USP in Adult Patients with Creatinine Clearance (CrCL) Greater Than 60 mL/minute

Site and Type of Infection	Dose	Frequency	Duration (days)
Adults	Intravenous (IV)		
Moderate to Severe Pneumonia [§]	1 to 2 g IV	Every 8 to 12 hours	10
Empiric therapy for febrile neutropenic patients	2 g IV	Every 8 hours	7*
Mild to Moderate Uncomplicated or Complicated Urinary Tract Infections, including pyelonephritis	0.5 to 1 g IV/IM**	Every 12 hours	7 to 10
Severe Uncomplicated or Complicated Urinary Tract Infections, including pyelonephritis	2 g IV	Every 12 hours	10
Moderate to Severe Uncomplicated Skin and Skin Structure Infections	2 g IV	Every 12 hours	10
Complicated Intra-abdominal Infections [§] (used in combination with metronidazole)	2 g IV	Every 8 to 12 hours	7 to 10

Cefepime for Injection, Pharmacy Bulk Package bag SmartPak® should not be used in patients who require less than a 500 mg dose of cefepime.

*or until resolution of neutropenia. In patients whose fever resolves but who remain neutropenic for more than 7 days, the need for continued antimicrobial therapy should be re-evaluated frequently.

**Intramuscular route of administration is indicated only for mild to moderate, uncomplicated or complicated UTIs due to *E. coli*.

[§]For *P. aeruginosa*, use 2 g IV every 8 hours.

2.2 Pediatric Patients (2 months up to 16 years)

Cefepime for Injection, Pharmacy Bulk Package bag SmartPak® should not be used in patients who require less than a 500 mg dose of cefepime.

The maximum dose for pediatric patients should not exceed the recommended adult dose.

The usual recommended dosage in pediatric patients up to 40 kg in weight for durations as given above for adults is:

- 50 mg per kg per dose, administered every 12 hours for uncomplicated and complicated urinary tract infections (including pyelonephritis), uncomplicated skin and skin structure infections, and pneumonia (see below).
- For moderate to severe pneumonia due to *P. aeruginosa* give 50 mg per kg per dose, every 8 hours.
- 50 mg per kg per dose, every 8 hours for febrile neutropenic patients.

2.3 Dosage Adjustments in Patients with Renal Impairment

Cefepime for Injection, Pharmacy Bulk Package bag SmartPak® should not be used in patients who require less than a 500 mg dose of cefepime.

Adult Patients

Adjust the dose of cefepime in patients with creatinine clearance less than or equal to 60 mL/min to compensate for the slower rate of renal elimination. In these patients, the recommended initial dose of cefepime should be the same as in patients with CrCL greater than 60 mL/min except in patients undergoing hemodialysis. The recommended doses of cefepime in patients with renal impairment are presented in Table 2.

When only serum creatinine is available, the following formula (Cockcroft and Gault equation)¹ may be used to estimate creatinine clearance. The serum creatinine should represent a steady state of renal function:

Males: Creatinine Clearance (mL/min) =	$\frac{\text{Weight (kg)} \times (140 - \text{age})}{72 \times \text{serum creatinine (mg/dL)}}$
Females: 0.85 × above value	

Table 2: Recommended Dosing Schedule for Cefepime for Injection, USP in Adult Patients With Creatinine Clearance Less Than or Equal to 60 mL/min

Creatinine Clearance (mL/min)	Recommended Maintenance Schedule			
Greater than 60	500 mg every 12 hours	1 g every 12 hours	2 g every 12 hours	2 g every 8 hours
30 to 60	500 mg every 24 hours	1 g every 24 hours	2 g every 24 hours	2 g every 12 hours
11 to 29	500 mg every 24 hours	500 mg every 24 hours	1 g every 24 hours	2 g every 24 hours
Less than 11	250 mg every 24 hours	250 mg every 24 hours	500 mg every 24 hours	1 g every 24 hours
Continuous Ambulatory Peritoneal Dialysis (CAPD)	500 mg every 48 hours	1 g every 48 hours	2 g every 48 hours	2 g every 48 hours
Hemodialysis*	1 g on day 1, then 500 mg every 24 hours thereafter			1 g every 24 hours

- * On hemodialysis days, cefepime should be administered following hemodialysis. Whenever possible, cefepime should be administered at the same time each day.

In patients undergoing Continuous Ambulatory Peritoneal Dialysis (CAPD), cefepime may be administered at the recommended doses at a dosage interval of every 48 hours (see Table 2).

In patients undergoing hemodialysis, approximately 68% of the total amount of cefepime present in the body at the start of dialysis will be removed during a 3-hour dialysis period. The dosage of cefepime for hemodialysis patients is 1 g on Day 1 followed by 500 mg every 24 hours for the treatment of all infections except febrile neutropenia, which is 1 g every 24 hours.

Cefepime should be administered at the same time each day and following the completion of hemodialysis on hemodialysis days (see Table 2).

Pediatric Patients

Data in pediatric patients with impaired renal function are not available; however, since cefepime pharmacokinetics are similar in adults and pediatric patients [see *Clinical Pharmacology* (12.3)], changes in the dosing regimen proportional to those in adults (see Tables 1 and 2) are recommended for pediatric patients.

2.4 Preparation for Use of Cefepime for Injection, USP, Pharmacy Bulk Package bags, SmartPak®

Cefepime for Injection, Pharmacy Bulk Package bag SmartPak® should not be used in patients who require less than a 500 mg dose of cefepime.

Directions for Proper Use of a Pharmacy Bulk Package

NOT FOR DIRECT INFUSION. The Pharmacy Bulk Package is for use in the hospital pharmacy admixture service only in a suitable work area, such as a laminar flow hood. Using aseptic technique, the container closure may be penetrated only one time after constitution using a suitable sterile dispensing set or transfer device that allows measured dispensing of the contents. Use of a syringe and needle is not recommended as it may cause leakage. The withdrawal of the container contents should be accomplished without delay. However, should this not be possible, a maximum time of **4 HOURS** from initial reconstitution port closure entry is permitted to complete fluid transfer operations. This time limit should begin with the introduction of the solvent or diluent into the Pharmacy Bulk Package. Discard any unused portion after **4 HOURS**. This pharmacy bulk package is not intended to be dispensed as a unit.

- **PRIOR TO CONSTITUTION: DO NOT USE THE INNER BAG IF PARTICULATE OR FOREIGN MATTER IS PRESENT, IF THE SEALS ARE NOT INTACT, OR IF THERE IS ANY OTHER DAMAGE TO THE BAG. IN SUCH CASE, DISCARD THE BAG IMMEDIATELY.**
- After initial reconstitution port entry, use entire contents of the Pharmacy Bulk Package promptly. Any unused portion must be discarded after **4 HOURS**.

INSTRUCTION FOR CONSTITUTION OF THE PHARMACY BULK PACKAGE BAG SmartPak®

The entire contents of the bag and the preparation process (constitution and dilution) should be completed within **4 hours** of initial entry.

SMARTPAK[®] INNER BAG

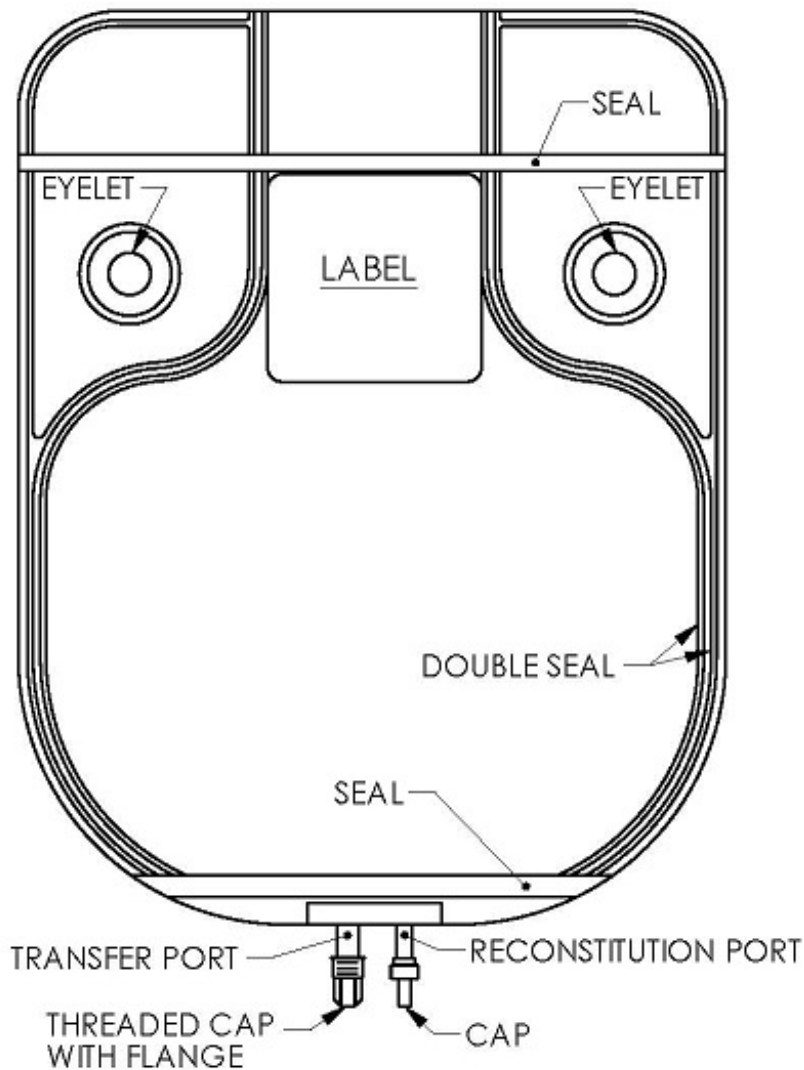

- Document the date and time constitution starts in the designated place on the container label. The entire contents of the bag must be used within **4 hours** from the time of initial entry.
- Remove the translucent unthreaded cap from the reconstitution (smaller) port, and discard it.
- Constitute the powder through the reconstitution (smaller) port, using Sterile Water for Injection according to Table 3 below.

Table 3: Constitution Table

SmartPak [®] Bag Size	Amount of Sterile Water	Approximate Concentration
100 grams	875 mL	100 mg/mL (1gram/10 mL)

- After constitution is complete, remove the transfer needle from the reconstitution port.
- Place the bag on a flat surface of a laminar flow hood and mix for at least 15 minutes by rocking gently from side to side. **CAUTION: To avoid possible leakage caused by the heavy weight of the added water, do not shake vigorously**

or pull strongly on the bag.

- When foam dissipates, visually inspect the bag to verify the solution is clear, pale yellow to amber and free of particulate matter. **DO NOT USE THE INNER BAG IF PARTICULATE OR FOREIGN MATTER IS PRESENT.**
- Unscrew the clear threaded cap from the transfer (larger) port and discard it. Attach sterile tubing and filling adapter unit to the transfer port.
- Constituted solution can now be transferred using the transfer port and the filling adapter.

It should be noted that the spike placed into the transfer port of the Pharmacy Bulk Package SmartPak® is NEVER removed during this procedure and that the reconstitution port is self-sealing.

Dilution

- Hang the bag from two eyelets.
- Following constitution, transfer 10 mL of the constituted solution into transfusion bags, each containing 50 mL of one of the compatible solutions below.

Compatible solutions for dilution are the following:

Sodium Chloride Injection, USP

5% Dextrose Injection, USP

- Dilution should be completed within the **4 hour** preparation process.
- When diluted according to the instructions above, cefepime is stable for 24 hours at room temperature 20°C to 25°C (68°F to 77°F) or 7 days in a refrigerator 2°C to 8°C (36°F to 46°F).

Important Administration Instructions

- Parenteral drugs should be inspected visually for particulate matter before administration. If particulate matter is evident in reconstituted fluids, the drug solution should be discarded.
- Administer the resulting diluted intravenous infusion over approximately 30 minutes.
- Intermittent intravenous infusion with a Y-type administration set can be accomplished with compatible solutions. However, during infusion of a solution containing cefepime, it is desirable to discontinue the other solution.
- Do not add solutions of cefepime, to solutions of ampicillin at a concentration greater than 40 mg per mL, or to metronidazole, vancomycin, gentamicin, tobramycin, netilmicin sulfate, or aminophylline because of potential interaction. However, if concurrent therapy with cefepime is indicated, each of these antibiotics can be administered separately.

3 DOSAGE FORMS AND STRENGTHS

Cefepime for Injection, USP is a sterile white to pale yellow powder in 100 gram SmartPak® Pharmacy Bulk Packages.

THIS IS A PHARMACY BULK PACKAGE – NOT FOR DIRECT INJECTION.

4 CONTRAINDICATIONS

Cefepime for Injection, USP is contraindicated in patients who have shown immediate hypersensitivity reactions to cefepime or the cephalosporin class of antibiotics, penicillins or other beta-lactam antibiotics.

5 WARNINGS AND PRECAUTIONS

5.1 Hypersensitivity Reactions

Before therapy with Cefepime for Injection, USP is instituted, careful inquiry should be made to determine whether the patient has had previous immediate hypersensitivity reactions to cefepime, cephalosporins, penicillins, or other beta-lactams. Exercise caution if this product is to be given to penicillin-sensitive patients because cross-hypersensitivity among beta-lactam antibacterial drugs has been clearly documented and may occur in up to 10% of patients with a history of penicillin allergy. If an allergic reaction to cefepime occurs, discontinue the drug and institute appropriate supportive measures.

5.2 Neurotoxicity

Serious adverse reactions have been reported including life-threatening or fatal occurrences of the following: encephalopathy (disturbance of consciousness including confusion, hallucinations, stupor, and coma), aphasia, myoclonus, seizures, and nonconvulsive status epilepticus [see *Adverse Reactions 6.2*]. Most cases occurred in patients with renal impairment who did not receive appropriate dosage adjustment. However, some cases of neurotoxicity occurred in patients receiving a dosage adjustment appropriate for their degree of renal impairment. In the majority of cases, symptoms of neurotoxicity were reversible and resolved after discontinuation of cefepime and/or after hemodialysis. If neurotoxicity associated with cefepime therapy occurs, discontinue cefepime and institute appropriate supportive measures.

5.3 *Clostridium difficile* Associated Diarrhea

Clostridium difficile associated diarrhea (CDAD) has been reported with use of nearly all antibacterial agents, including cefepime, and may range in severity from mild diarrhea to fatal colitis. Treatment with antibacterial agents alters the normal flora of the colon leading to overgrowth of *C. difficile*.

C. difficile produces toxins A and B, which contribute to the development of CDAD. Hypertoxin-producing strains of *C. difficile* cause increased morbidity and mortality, as these infections can be refractory to antimicrobial therapy and may require colectomy. CDAD must be considered in all patients who present with diarrhea following antibacterial drug use. Careful medical history is necessary since CDAD has been reported to occur over two months after the administration of antibacterial agents.

If CDAD is suspected or confirmed, ongoing antibacterial drug use not directed against *C. difficile* may need to be discontinued. Appropriate fluid and electrolyte management, protein supplementation, antibiotic treatment of *C. difficile*, and surgical evaluation should be instituted as clinically indicated.

5.4 Development of Drug-Resistant Bacteria

Prescribing cefepime in the absence of a proven or strongly suspected bacterial

infection is unlikely to provide benefit to the patient and increases the risk of the development of drug-resistant bacteria.

As with other antimicrobials, prolonged use of cefepime may result in overgrowth of nonsusceptible microorganisms. Repeated evaluation of the patient's condition is essential. Should superinfection occur during therapy, appropriate measures should be taken.

5.5 Drug/Laboratory Test Interactions

Urinary Glucose

The administration of cefepime may result in a false-positive reaction for glucose in the urine when using some methods (e.g. Clinitest™ tablets) [see *Drug Interactions (7.1)*].

Coombs' Tests

Positive direct Coombs' tests have been reported during treatment with cefepime. In patients who develop hemolytic anemia, discontinue the drug and institute appropriate therapy. Positive Coombs' test may be observed in newborns whose mothers have received cephalosporin antibiotics before parturition.

Prothrombin Time

Many cephalosporins, including cefepime, have been associated with a fall in prothrombin activity. Those at risk include patients with renal or hepatic impairment, or poor nutritional state, as well as patients receiving a protracted course of antimicrobial therapy. Prothrombin time should be monitored in patients at risk, and exogenous vitamin K administered as indicated.

6 ADVERSE REACTIONS

The following adverse reactions are discussed in the Warnings and Precautions section and below:

- Hypersensitivity Reactions [see *Warnings and Precautions (5.1)*]
- Neurotoxicity [see *Warnings and Precautions (5.2)*]
- *Clostridium difficile*-Associated Diarrhea [see *Warnings and Precautions (5.3)*]

6.1 Clinical Trials Experience

Because clinical trials are conducted under widely varying conditions, adverse reaction rates observed in clinical trials of a drug cannot be directly compared to rates in the clinical trials of another drug and may not reflect the rates observed in practice.

In clinical trials using multiple doses of cefepime, 4137 patients were treated with the recommended dosages of cefepime (500 mg to 2 g intravenous every 12 hours). There were no deaths or permanent disabilities thought related to drug toxicity. Sixty-four (1.5%) patients discontinued medication due to adverse reactions. Thirty-three (51%) of these 64 patients who discontinued therapy did so because of rash. The percentage of cefepime-treated patients who discontinued study drug because of drug-related adverse reactions was very similar at daily doses of 500 mg, 1 g, and 2 g every 12 hours (0.8%, 1.1%, and 2%, respectively). However, the incidence of discontinuation due to rash increased with the higher recommended doses.

The following adverse events (Table 4) were identified in clinical trials conducted in North America (n=3125 cefepime-treated patients).

Table 4: Adverse Reactions Cefepime Multiple-Dose Dosing Regimens Clinical Trials in North America

Incidence equal to or greater than 1%	Local adverse reactions (3%), including phlebitis (1.3%), pain and/or inflammation (0.6%)*; rash (1.1%)
Incidence less than 1% but greater than 0.1%	Colitis (including pseudomembranous colitis), diarrhea, erythema, fever, headache, nausea, oral moniliasis, pruritus, urticaria, vaginitis, vomiting, anemia

* Local reactions, irrespective of relationship to cefepime in those patients who received intravenous infusion (n=3048).

At the higher dose of 2 g every 8 hours, the incidence of adverse events was higher among the 795 patients who received this dose of cefepime. They consisted of rash (4%), diarrhea (3%), nausea (2%), vomiting (1%), pruritus (1%), fever (1%), and headache (1%).

The following (Table 5) adverse laboratory changes, with cefepime, were seen during clinical trials conducted in North America.

Table 5: Adverse Laboratory Changes in Cefepime Multiple-Dose Dosing Regimens Clinical Trials in North America

Incidence equal to or greater than 1%	Positive Coombs test (without hemolysis) (16.2%); decreased phosphorus (2.8%); increased Alanine Transaminase (ALT) (2.8%), Aspartate Transaminase (AST) (2.4%), eosinophils (1.7%); abnormal PTT (1.6%), Prothrombin Time (PT) (1.4%)
Incidence less than 1% but greater than 0.1%	Increased alkaline phosphatase, Blood Urea Nitrogen (BUN), calcium, creatinine, phosphorus, potassium, total bilirubin; decreased calcium*, hematocrit, neutrophils, platelets, White Blood Cells (WBC)

* Hypocalcemia was more common among elderly patients. Clinical consequences from changes in either calcium or phosphorus were not reported.

A similar safety profile was seen in clinical trials of pediatric patients.

6.2 Postmarketing Experience

The following adverse reactions have been identified during post-approval use of cefepime. Because these reactions are reported voluntarily from a population of uncertain size, it is not always possible to reliably estimate their frequency or establish a

causal relationship to drug exposure.

In addition to the adverse reactions reported in North American clinical trials with cefepime, the following adverse reactions have been reported during worldwide postmarketing experience. Encephalopathy (disturbance of consciousness including confusion, hallucinations, stupor, and coma), aphasia, myoclonus, seizures, and nonconvulsive status epilepticus have been reported. [see *Warnings and Precautions* (5.2)]

Anaphylaxis including anaphylactic shock, transient leukopenia, neutropenia, agranulocytosis and thrombocytopenia have been reported.

6.3 Cephalosporin-Class Adverse Reactions

In addition to the adverse reactions listed above that have been observed in patients treated with cefepime, the following adverse reactions and altered laboratory tests have been reported for cephalosporin-class antibacterial drugs:

Stevens-Johnson syndrome, erythema multiforme, toxic epidermal necrolysis, renal dysfunction, toxic nephropathy, aplastic anemia, hemolytic anemia, hemorrhage, hepatic dysfunction including cholestasis, and pancytopenia.

7 DRUG INTERACTIONS

7.1 Drug/Laboratory Test Interactions

The administration of cefepime may result in a false-positive reaction for glucose in the urine with certain methods. It is recommended that glucose tests based on enzymatic glucose oxidase reactions be used.

7.2 Aminoglycosides

Monitor renal function if aminoglycosides are to be administered with cefepime because of the increased potential of nephrotoxicity and ototoxicity of aminoglycoside antibacterial drugs.

7.3 Diuretics

Nephrotoxicity has been reported following concomitant administration of other cephalosporins with potent diuretics such as furosemide. Monitor renal function when cefepime is concomitantly administered with potent diuretics.

8 USE IN SPECIFIC POPULATIONS

8.1 Pregnancy

Pregnancy Category B

There are no adequate and well-controlled studies of cefepime use in pregnant women. Because animal reproduction studies are not always predictive of human response, this drug should be used during pregnancy only if clearly needed.

Cefepime was not teratogenic or embryocidal when administered during the period of

organogenesis to rats at doses up to 1000 mg/kg/day (1.6 times the recommended human dose calculated on a body surface area basis) or to mice at doses up to 1200 mg/kg (approximately equal to the recommended maximum human dose calculated on a body surface area basis) or to rabbits at a dose level of 100 mg/kg (0.3 times the recommended maximum human dose calculated on a body surface area basis).

8.2 Labor and Delivery

Cefepime has not been studied for use during labor and delivery. Treatment should only be given if clearly indicated.

8.3 Nursing Mothers

Cefepime is excreted in human breast milk. Caution should be exercised when cefepime is administered to a nursing woman [see *Clinical Pharmacology* (12.3)].

8.4 Pediatric Use

Cefepime for Injection, Pharmacy Bulk Package bag SmartPak® should not be used in pediatric patients who require less than a 500 mg dose of cefepime.

The safety and effectiveness of cefepime in the treatment of uncomplicated and complicated urinary tract infections (including pyelonephritis), uncomplicated skin and skin structure infections, pneumonia, and as empiric therapy for febrile neutropenic patients have been established in the age groups 2 months up to 16 years. Use of cefepime in these age groups is supported by evidence from adequate and well-controlled studies of cefepime in adults with additional pharmacokinetic and safety data from pediatric trials [see *Clinical Pharmacology* (12.3)].

Safety and effectiveness in pediatric patients below the age of 2 months have not been established. There are insufficient clinical data to support the use of cefepime in pediatric patients for the treatment of serious infections in the pediatric population where the suspected or proven pathogen is *H. influenzae* type b. In those patients in whom meningeal seeding from a distant infection site or in whom meningitis is suspected or documented, an alternate agent with demonstrated clinical efficacy in this setting should be used.

8.5 Geriatric Use

Of the more than 6400 adults treated with cefepime in clinical studies, 35% were 65 years or older while 16% were 75 years or older. When geriatric patients received the usual recommended adult dose, clinical efficacy and safety were comparable to clinical efficacy and safety in non-geriatric adult patients.

Serious adverse events have occurred in geriatric patients with renal insufficiency given unadjusted doses of cefepime, including life-threatening or fatal occurrences of the following: encephalopathy, myoclonus, and seizures [see *Warnings and Precautions* (5.2), *Adverse Reactions* (6.2)].

This drug is known to be substantially excreted by the kidney, and the risk of toxic reactions to this drug may be greater in patients with impaired renal function. Because elderly patients are more likely to have decreased renal function, care should be taken in dose selection, and renal function should be monitored [see *Clinical Pharmacology*

(12.3), Warnings and Precautions (5.2), Dosage and Administration (2.3)].

8.6 Renal Impairment

Cefepime for Injection, Pharmacy Bulk Package bag SmartPak® should not be used in patients with renal impairment who require less than a 500 mg dose of cefepime.

Adjust the dose of cefepime in patients with creatinine clearance less than or equal to 60 mL/min to compensate for the slower rate of renal elimination. [see *Dosage Adjustments in Patients with Renal Impairment* (2.3)]

10 OVERDOSAGE

Patients who receive an overdose should be carefully observed and given supportive treatment. In the presence of renal insufficiency, hemodialysis, not peritoneal dialysis, is recommended to aid in the removal of cefepime from the body. Symptoms of overdose include encephalopathy (disturbance of consciousness including confusion, hallucinations, stupor, and coma), myoclonus, seizures, neuromuscular excitability and nonconvulsive status epilepticus [see *Warnings and Precautions* (5.2), *Adverse Reactions* (6.2), *Dosage and Administration* (2.3)].

11 DESCRIPTION

Cefepime for Injection, Pharmacy Bulk Package bag SmartPak® should not be used in patients who require less than a 500 mg dose of cefepime.

Cefepime for Injection, USP is a semi-synthetic, cephalosporin antibacterial for parenteral administration. The chemical name is 1-[[[(6R,7R)-7-[2-(2-amino-4-thiazolyl)-glyoxylamido]-2-carboxy-8-oxo-5-thia-1-azabicyclo[4.2.0] oct-2-en-3-yl]methyl]-1-methylpyrrolidinium chloride, 7²-(Z)-(O-methyloxime), monohydrochloride, monohydrate, which corresponds to the following structural formula:

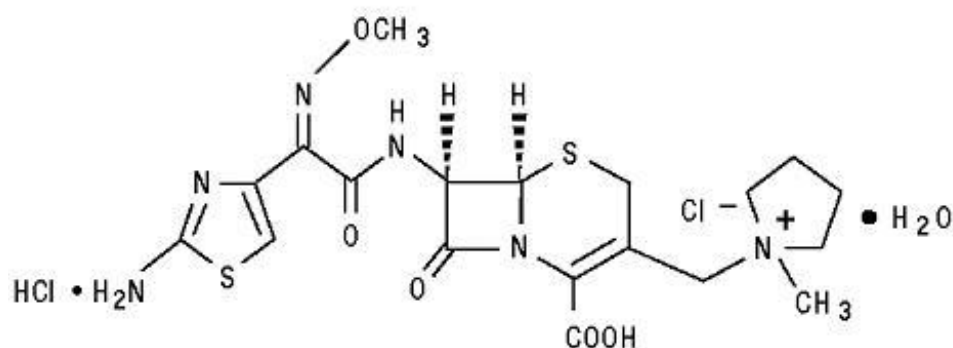

BEFORE ADMINISTRATION, THIS PHARMACY BULK PACKAGE REQUIRES CONSTITUTION USING STERILE WATER FOR INJECTION, USP TO A CONCENTRATION OF 100 MG PER ML AND FURTHER DILUTION IN 50 ML OF A COMPATIBLE SOLUTION AND INFUSED INTRAVENOUSLY.

Cefepime hydrochloride is a white to pale yellow powder. Cefepime hydrochloride contains the equivalent of not less than 825 mcg and not more than 911 mcg of cefepime (C₁₉H₂₄N₆O₅S₂) per mg, calculated on an anhydrous basis. It is highly soluble

in water.

Cefepime for Injection, USP is supplied in a SmartPak[®] pharmacy bulk package containing the equivalent of 100 grams of cefepime. Cefepime for Injection is a sterile, dry mixture of cefepime hydrochloride and L-arginine. The L-arginine, at an approximate concentration of 707 mg/g of cefepime, is added to control the pH of the constituted solution at 4 to 6. Freshly constituted solutions of Cefepime for Injection will range in color from pale yellow to amber.

Each SmartPak[®] Pharmacy Bulk Package contains sterile Cefepime Hydrochloride, USP, equivalent to 100 grams of cefepime and is intended for intravenous infusion only. Its L-arginine content is approximately 70.7 grams. A Pharmacy Bulk Package is a container of a sterile preparation for parenteral use that contains many single doses. The contents are intended for use in a pharmacy admixture service and are restricted to the preparation of admixtures for intravenous infusion. **FURTHER DILUTION IS REQUIRED BEFORE USE. CONSTITUTED BULK SOLUTION SHOULD NOT BE USED FOR DIRECT INFUSION.**

12 CLINICAL PHARMACOLOGY

12.1 Mechanism of Action

Cefepime is a cephalosporin antibacterial drug [see *Microbiology (12.4)*].

12.2 Pharmacodynamics

Similar to other beta-lactam antimicrobial agents, the time that the unbound plasma concentration of cefepime exceeds the MIC of the infecting organism has been shown to best correlate with efficacy in animal models of infection. However, the pharmacokinetic/pharmacodynamics relationship for cefepime has not been evaluated in patients.

12.3 Pharmacokinetics

Pharmacokinetic parameters for cefepime in healthy adult male volunteers (n=9) following single 30-minute infusions (IV) of cefepime 500 mg, 1 g, and 2 g are summarized in Table 6. Elimination of cefepime is principally via renal excretion with an average (\pm SD) half-life of 2 (\pm 0.3) hours and total body clearance of 120 (\pm 8) mL/min in healthy volunteers. Cefepime pharmacokinetics are linear over the range 250 mg to 2 g. There is no evidence of accumulation in healthy adult male volunteers (n=7) receiving clinically relevant doses for a period of 9 days.

Table 6: Pharmacokinetic Parameters for Cefepime (\pm SD), Intravenous Administration

Parameter	CEFEPIME		
	500 mg IV	1 g IV	2 g IV
C _{max} , mcg/mL	39.1 (3.5)	81.7 (5.1)	163.9 (25.3)
AUC, h x mcg/mL	70.8 (6.7)	148.5 (15.1)	284.8 (30.6)
Number of subjects (male)	9	9	9

Pharmacokinetic parameters for cefepime following a single intramuscular injection are summarized in Table 7. The pharmacokinetics of cefepime are linear over the range of 500 mg to 2 g intramuscularly and do not vary with respect to treatment duration.

Table 7: Mean Pharmacokinetic Parameters for Cefepime (\pm SD), Intramuscular Administration

Parameter	CEFEPIME		
	500 mg IV	1 g IM	2 g IM
C _{max} , mcg/mL	13.9 (3.4)	29.6 (4.4)	57.5 (9.5)
T _{max} , h	1.4 (0.9)	1.6 (0.4)	1.5 (0.4)
AUC, h x mcg/mL	60 (8)	137 (11)	137 (11)
Number of subjects (male)	6	6	12

Absorption

Following intramuscular (IM) administration, cefepime is completely absorbed.

Distribution

The average steady-state volume of distribution of cefepime is 18 (\pm 2) L. The serum protein binding of cefepime is approximately 20% and is independent of its concentration in serum.

Cefepime is excreted in human milk at a concentration of 0.5 mcg/mL. A nursing infant consuming approximately 1000 mL of human milk per day would receive approximately 0.5 mg of cefepime per day [see Use in Specific Populations (8.3)].

Concentrations of cefepime achieved in specific tissues and body fluids are listed in Table 8.

Table 8: Mean Concentrations of Cefepime in Specific Body Fluids (mcg/mL) or Tissues (mcg/g)

Tissue or Fluid	Dose/Route	# of Patients	Mean Time of Sample Post-Dose (h)	Mean Concentration
Blister Fluid	2 g IV	6	1.5	81.4 mcg/mL
Bronchial Mucosa	2 g IV	20	4.8	24.1 mcg/g
Sputum	2 g IV	5	4	7.4 mcg/mL
	500 mg IV	8	0 to 4	292 mcg/mL
Urine	1 g IV	12	0 to 4	926 mcg/mL
	2 g IV	12	0 to 4	3120 mcg/mL
Bile	2 g IV	26	9.4	17.8 mcg/mL
Peritoneal Fluid	2 g IV	19	4.4	18.3 mcg/mL
Appendix	2 g IV	31	5.7	5.2 mcg/g
Gallbladder	2 g IV	38	8.9	11.9 mcg/g
Prostate	2 g IV	5	1	31.5 mcg/g

Data suggest that cefepime does cross the inflamed blood-brain barrier. The clinical relevance of these data is uncertain at this time.

Metabolism and Excretion

Cefepime is metabolized to N-methylpyrrolidine (NMP) which is rapidly converted to the N-oxide (NMP-N-oxide). Urinary recovery of unchanged cefepime accounts for approximately 85% of the administered dose. Less than 1% of the administered dose is recovered from urine as NMP, 6.8% as NMP-N-oxide, and 2.5% as an epimer of cefepime. Because renal excretion is a significant pathway of elimination, patients with renal dysfunction and patients undergoing hemodialysis require dosage adjustment [see Dosage and Administration (2.3)].

Specific Populations

Patients with Renal impairment

Cefepime pharmacokinetics have been investigated in patients with various degrees of renal impairment (n=30). The average half-life in patients requiring hemodialysis was 13.5 (\pm 2.7) hours and in patients requiring continuous peritoneal dialysis was 19 (\pm 2) hours. Cefepime total body clearance decreased proportionally with creatinine clearance in patients with abnormal renal function, which serves as the basis for dosage adjustment recommendations in this group of patients [see Dosage and Administration (2.3)].

Patients with Hepatic impairment

The pharmacokinetics of cefepime were unaltered in patients with hepatic impairment who received a single 1 g dose (n=11).

Geriatric Patients

Cefepime pharmacokinetics have been investigated in elderly (65 years of age and older) men (n=12) and women (n=12) whose mean (SD) creatinine clearance was 74 (\pm 15) mL/min. There appeared to be a decrease in cefepime total body clearance as a function of creatinine clearance. Therefore, dosage administration of cefepime in the elderly should be adjusted as appropriate if the patient's creatinine clearance is 60 mL/minute or less [see Dosage and Administration (2.3)].

Pediatric Patients

Cefepime pharmacokinetics have been evaluated in pediatric patients from 2 months to 11 years of age following single and multiple doses on every 8 hours (n=29) and every 12 hours (n=13) schedules. Following a single intravenous dose, total body clearance and the steady-state volume of distribution averaged 3.3 (\pm 1) mL/min/kg and 0.3 (\pm 0.1) L/kg, respectively. The urinary recovery of unchanged cefepime was 60.4 (\pm 30.4)% of the administered dose, and the average renal clearance was 2 (\pm 1.1) mL/min/kg. There were no significant effects of age or gender (25 male vs. 17 female) on total body clearance or volume of distribution, corrected for body weight. No accumulation was seen when cefepime was given at 50 mg per kg every 12 hours (n=13), while C_{max} , AUC, and $t_{1/2}$ were increased about 15% at steady state after 50 mg per kg every 8 hours. The exposure to cefepime following a 50 mg per kg intravenous dose in a pediatric patient is comparable to that in an adult treated with a 2 g intravenous dose. The absolute bioavailability of cefepime after an intramuscular dose of 50 mg per kg was 82.3 (\pm 15)% in eight patients.

12.3 Pharmacokinetics

Pharmacokinetic parameters for cefepime in healthy adult male volunteers (n=9) following single 30-minute infusions (IV) of cefepime 500 mg, 1 g, and 2 g are summarized in Table 6. Elimination of cefepime is principally via renal excretion with an average (\pm SD) half-life of 2 (\pm 0.3) hours and total body clearance of 120 (\pm 8) mL/min in healthy volunteers. Cefepime pharmacokinetics are linear over the range 250 mg to 2 g. There is no evidence of accumulation in healthy adult male volunteers (n=7) receiving clinically relevant doses for a period of 9 days.

Table 6: Mean Pharmacokinetic Parameters for Cefepime (\pm SD), Intravenous Administration

Parameter	CEFEPIME		
	500 mg IV	1 g IV	2 g IV
C _{max} , mcg/mL	39.1 (3.5)	81.7 (5.1)	163.9 (25.3)
AUC, h x mcg/mL	70.8 (6.7)	148.5 (15.1)	284.8 (30.6)
Number of subjects (male)	9	9	9

Pharmacokinetic parameters for cefepime following a single intramuscular injection are summarized in Table 7. The pharmacokinetics of cefepime are linear over the range of 500 mg to 2 g intramuscularly and do not vary with respect to treatment duration.

Table 7: Mean Pharmacokinetic Parameters for Cefepime (\pm SD), Intramuscular Administration

Parameter	CEFEPIME		
	500 mg IM	1 g IM	2 g IM
C _{max} , mcg/mL	13.9 (3.4)	29.6 (4.4)	57.5 (9.5)
T _{max} , h	1.4 (0.9)	1.6 (0.4)	1.5 (0.4)
AUC, h x mcg/mL	60 (8)	137 (11)	262 (23)
Number of subjects (male)	6	6	12

Absorption

Following intramuscular (IM) administration, cefepime is completely absorbed.

Distribution

The average steady-state volume of distribution of cefepime is 18 (\pm 2) L. The serum protein binding of cefepime is approximately 20% and is independent of its concentration in serum.

Cefepime is excreted in human milk at a concentration of 0.5 mcg/mL. A nursing infant consuming approximately 1000 mL of human milk per day would receive approximately 0.5 mg of cefepime per day [see *Use in Specific Populations* (8.3)].

Concentrations of cefepime achieved in specific tissues and body fluids are listed in Table 8.

Table 8: Mean Concentrations of Cefepime in Specific Body Fluids (mcg/mL) or Tissues (mcg/g)

Tissue or Fluid	Dose/Route	# of Patients	Mean Time of Sample Post-Dose (h)	Mean Concentration
Blister Fluid	2 g IV	6	1.5	81.4 mcg/mL
Bronchial Mucosa	2 g IV	20	4.8	24.1 mcg/g
Sputum	2 g IV	5	4	7.4 mcg/mL
Urine	500 mg IV	8	0 to 4	292 mcg/mL
	1 g IV	12	0 to 4	926 mcg/mL
	2 g IV	12	0 to 4	3120 mcg/mL
Bile	2 g IV	26	9.4	17.8 mcg/mL
Peritoneal Fluid	2 g IV	19	4.4	18.3 mcg/mL
Appendix	2 g IV	31	5.7	5.2 mcg/g
Gallbladder	2 g IV	38	8.9	11.9 mcg/g
Prostate	2 g IV	5	1	31.5 mcg/g

Data suggest that cefepime does cross the inflamed blood-brain barrier. The clinical relevance of these data is uncertain at this time.

Metabolism and Excretion

Cefepime is metabolized to N-methylpyrrolidine (NMP) which is rapidly converted to the N-oxide (NMP-N-oxide). Urinary recovery of unchanged cefepime accounts for approximately 85% of the administered dose. Less than 1% of the administered dose is recovered from urine as NMP, 6.8% as NMP-N-oxide, and 2.5% as an epimer of cefepime. Because renal excretion is a significant pathway of elimination, patients with renal dysfunction and patients undergoing hemodialysis require dosage adjustment [see *Dosage and Administration (2.3)*].

Specific Populations

Patients with Renal impairment

Cefepime pharmacokinetics have been investigated in patients with various degrees of renal impairment (n=30). The average half-life in patients requiring hemodialysis was 13.5 (\pm 2.7) hours and in patients requiring continuous peritoneal dialysis was 19 (\pm 2) hours. Cefepime total body clearance decreased proportionally with creatinine clearance in patients with abnormal renal function, which serves as the basis for dosage adjustment recommendations in this group of patients [see *Dosage and Administration (2.3)*].

Patients with Hepatic impairment

The pharmacokinetics of cefepime were unaltered in patients with hepatic impairment who received a single 1 g dose (n=11).

Geriatric Patients

Cefepime pharmacokinetics have been investigated in elderly (65 years of age and older)

men (n=12) and women (n=12) whose mean (SD) creatinine clearance was 74 (\pm 15) mL/min. There appeared to be a decrease in cefepime total body clearance as a function of creatinine clearance. Therefore, dosage administration of cefepime in the elderly should be adjusted as appropriate if the patient's creatinine clearance is 60 mL/minute or less [see *Dosage and Administration* (2.3)].

Pediatric Patients

Cefepime pharmacokinetics have been evaluated in pediatric patients from 2 months to 11 years of age following single and multiple doses on every 8 hours (n=29) and every 12 hours (n=13) schedules. Following a single intravenous dose, total body clearance and the steady-state volume of distribution averaged 3.3 (\pm 1) mL/min/kg and 0.3 (\pm 0.1) L/kg, respectively. The urinary recovery of unchanged cefepime was 60.4 (\pm 30.4)% of the administered dose, and the average renal clearance was 2 (\pm 1.1) mL/min/kg. There were no significant effects of age or gender (25 male vs. 17 female) on total body clearance or volume of distribution, corrected for body weight. No accumulation was seen when cefepime was given at 50 mg per kg every 12 hours (n=13), while C_{max} , AUC, and $t_{1/2}$ were increased about 15% at steady state after 50 mg per kg every 8 hours. The exposure to cefepime following a 50 mg per kg intravenous dose in a pediatric patient is comparable to that in an adult treated with a 2 g intravenous dose. The absolute bioavailability of cefepime after an intramuscular dose of 50 mg per kg was 82.3 (\pm 15)% in eight patients.

12.4 Microbiology

Mechanism of Action

Cefepime is a bactericidal drug that acts by inhibition of bacterial cell wall synthesis. Cefepime has a broad spectrum of *in vitro* activity that encompasses a wide range of Gram-positive and Gram-negative bacteria. Within bacterial cells, the molecular targets of cefepime are the penicillin binding proteins (PBP).

Antimicrobial Activity

Cefepime has been shown to be active against most isolates of the following microorganisms, both *in vitro* and in clinical infections as described in the Indications and Usage section (1).

Gram-negative Bacteria

Enterobacter spp.

Escherichia coli

Klebsiella pneumoniae

Proteus mirabilis

Pseudomonas aeruginosa

Gram-positive Bacteria

Staphylococcus aureus (methicillin-susceptible isolates only)

Streptococcus pneumoniae

Streptococcus pyogenes

Viridans group streptococci

The following *in vitro* data are available, but their clinical significance is unknown. At least 90 percent of the following bacteria exhibit an *in vitro* minimum inhibitory concentration (MIC) less than or equal to the susceptible breakpoint for cefepime against isolates of similar genus or organism group. However, the efficacy of cefepime in treating clinical infections due to these bacteria has not been established in adequate and well-controlled clinical trials.

Gram-positive Bacteria

Staphylococcus epidermidis (methicillin-susceptible isolates only)

Staphylococcus saprophyticus

Streptococcus agalactiae

NOTE: Most isolates of enterococci, e.g., *Enterococcus faecalis*, and methicillin-resistant staphylococci are resistant to cefepime.

Gram-negative Bacteria

Acinetobacter calcoaceticus subsp. *lwoffii*

Citrobacter diversus

Citrobacter freundii

Enterobacter agglomerans

Haemophilus influenzae

Hafnia alvei

Klebsiella oxytoca

Moraxella catarrhalis

Morganella morganii

Proteus vulgaris

Providencia rettgeri

Providencia stuartii

Serratia marcescens

NOTE: Cefepime is inactive against many isolates of *Stenotrophomonas maltophilia*.

Susceptibility Test Methods

For specific information regarding susceptibility test interpretive criteria and associated test methods and quality control standards recognized by FDA for this drug, please see: <https://www.fda.gov/STIC>.

13 NONCLINICAL TOXICOLOGY

13.1 Carcinogenesis, Mutagenesis, Impairment of Fertility

No animal carcinogenicity studies have been conducted with cefepime. In chromosomal

aberration studies, cefepime was positive for clastogenicity in primary human lymphocytes, but negative in Chinese hamster ovary cells. In other *in vitro* assays (bacterial and mammalian cell mutation, DNA repair in primary rat hepatocytes, and sister chromatid exchange in human lymphocytes), cefepime was negative for genotoxic effects. Moreover, *in vivo* assessments of cefepime in mice (2 chromosomal aberration and 2 micronucleus studies) were negative for clastogenicity. No untoward effects on fertility were observed in rats when cefepime was administered subcutaneously at doses up to 1000 mg/kg/day (1.6 times the recommended maximum human dose calculated on a body surface area basis).

14 CLINICAL STUDIES

14.1 Febrile Neutropenic Patients

The safety and efficacy of empiric cefepime monotherapy of febrile neutropenic patients have been assessed in two multicenter, randomized trials comparing cefepime monotherapy (at a dose of 2 g intravenously every 8 hours) to ceftazidime monotherapy (at a dose of 2 g intravenously every 8 hours). These studies comprised 317 evaluable patients. Table 9 describes the characteristics of the evaluable patient population.

Table 9: Demographics of Evaluable Patients (First Episodes Only)

Total	Cefepime	Ceftazidime
	164	153
Median age (yr)	56 (range, 18 to 82)	55 (range, 16 to 84)
Male	86 (52%)	85 (56%)
Female	78 (48%)	68 (44%)
Leukemia	65 (40%)	52 (34%)
Other hematologic malignancies	43 (26%)	36 (24%)
Solid tumor	54 (33%)	56 (37%)
Median ANC nadir (cells/microliter)	20 (range, 0 to 500)	20 (range, 0 to 500)
Median duration of neutropenia (days)	6 (range, 0 to 39)	6 (range, 0 to 32)
Indwelling venous catheter	97 (59%)	86 (56%)
Prophylactic antibiotics	62 (38%)	64 (42%)
Bone marrow graft	9 (5%)	7 (5%)
SBP less than 90 mm Hg at entry	7 (4%)	2 (1%)

ANC = absolute neutrophil count; SBP = systolic blood pressure

Table 10 describes the clinical response rates observed. For all outcome measures, cefepime was therapeutically equivalent to ceftazidime.

Table 10: Pooled Response Rates for Empiric Therapy of Febrile Neutropenic Patients

Outcome Measures	% Response	
	Cefepime	Ceftazidime

	(n=164)	(n=153)
Primary episode resolved with no treatment modification, no new febrile episodes or infection, and oral antibiotics allowed for completion of treatment	51	55
Primary episode resolved with no treatment modification, no new febrile episodes or infection and no post-treatment oral antibiotics	34	39
Survival, any treatment modification allowed	93	97
Primary episode resolved with no treatment modification and oral antibiotics allowed for completion of treatment	62	67
Primary episode resolved with no treatment modification and no post-treatment oral antibiotics	46	51

Insufficient data exist to support the efficacy of cefepime monotherapy in patients at high risk for severe infection (including patients with a history of recent bone marrow transplantation, with hypotension at presentation, with an underlying hematologic malignancy, or with severe or prolonged neutropenia). No data are available in patients with septic shock.

14.2 Complicated Intra-abdominal Infections

Patients hospitalized with complicated intra-abdominal infections participated in a randomized, double-blind, multicenter trial comparing the combination of cefepime (2 g every 12 hours) plus intravenous metronidazole (500 mg every 6 hours) versus imipenem/cilastatin (500 mg every 6 hours) for a maximum duration of 14 days of therapy. The study was designed to demonstrate equivalence of the two therapies. The primary analyses were conducted on the population consisting of those with a surgically confirmed complicated infection, at least one pathogen isolated pretreatment, at least 5 days of treatment and a 4 to 6 week follow-up assessment for cured patients. Subjects in the imipenem/cilastatin arm had higher APACHE II scores at baseline. The treatment groups were otherwise generally comparable with regard to their pretreatment characteristics. The overall clinical cure rate among the primary analysis patients was 81% (51 cured/63 evaluable patients) in the cefepime plus metronidazole group and 66% (62/94) in the imipenem/cilastatin group. The observed differences in efficacy may have been due to a greater proportion of patients with high APACHE II scores in the imipenem/cilastatin group.

15 REFERENCES

1. Cockcroft DW, Gault MH. Prediction of creatinine clearance from serum creatinine. *Nephron*. 1976; 16:31-41.

16 HOW SUPPLIED/STORAGE AND HANDLING

How Supplied

Cefepime for Injection, USP in the dry state is a white to pale yellow powder. Constituted solutions of Cefepime for Injection, USP can range in color from pale yellow to amber. Cefepime for Injection, USP is available in the following SmartPakPharmacy Bulk

Package:

100 grams* (1 Pharmacy Bulk Package) Product No. 8100 NDC 66288-8100-1 sold in individual bags.

*Each 100 gram Pharmacy Bulk Package contains sterile cefepime hydrochloride equivalent to 100 grams of cefepime and 70.7 grams of L-arginine.

SmartPak[®] system components are not made with natural rubber latex.

Storage and Handling

Cefepime for Injection, USP in the dry state should be stored at 20 to 25°C (68 to 77°F) [see USP controlled room temperature.] and protected from light. The inner bag should be retained in the outer bag until time of use.

17 PATIENT COUNSELING INFORMATION

- Counsel patients that antibacterial drugs including Cefepime for Injection, USP should only be used to treat bacterial infections. They do not treat viral infections (e.g., the common cold). When cefepime is prescribed to treat a bacterial infection, tell patients that although it is common to feel better early in the course of therapy, the medication should be taken exactly as directed. Skipping doses or not completing the full course of therapy may (1) decrease the effectiveness of the immediate treatment and (2) increase the likelihood that bacteria will develop resistance and will not be treatable by cefepime or other antibacterial drugs in the future.
- Diarrhea is a common problem caused by antibacterial drugs, which usually ends when the antibiotic is discontinued. Inform the patient that they may develop watery and bloody stools (with or without stomach cramps and fever) during treatment and as late as two or more months after having taken the last dose of the antibiotic. Inform patients that they should contact their physician as soon as possible if this occurs.
- Advise patients of neurological adverse events that could occur with cefepime use. Instruct patients or their caregivers to inform their healthcare provider at once of any neurological signs and symptoms, including encephalopathy (disturbance of consciousness including confusion, hallucinations, stupor, and coma), aphasia (disturbance of speaking and understanding spoken and written language), myoclonus, seizures and nonconvulsive status epilepticus, for immediate treatment, dosage adjustment, or discontinuation of cefepime.

Rx only

SmartPak is a registered trademark of Samson Medical Technologies, L.L.C.

C8100a

Manufactured for Samson Medical Technologies, L.L.C.

Cherry Hill, NJ 08003

by

ACS Dobfar S.p.A.

20067 Tribiano (Milano) Italy

Printed in USA *6628881001*

NDC 66288-8100-1 SmartPak

Cefepime for Injection, USP

100 grams [ONE HUNDRED GRAMS] per Pharmacy Bulk Package Bag

PHARMACY BULK PACKAGE -

NOT FOR DIRECT INFUSION

FOR INTRAVENOUS USE ONLY

NOT TO BE DISPENSED AS A UNIT

Rx Only

IMPORTANT: READ PACKAGE INSERT FOR PRECAUTIONS AND DIRECTIONS FOR USE.
AFTER CONSTITUTION, MUST BE FURTHER DILUTED.

Sterile, Nonpyrogenic, Preservative-Free

Each 100 gram Pharmacy Bulk Package contains sterile cefepime hydrochloride equivalent to 100 grams of cefepime and L-arginine for pH adjustment.

USUAL DOSAGE: See package insert.

Prior to constitution, store dry powder at 20° to 25°C (68° to 77°F).

[see USP Controlled Room Temperature.]

After constitution, dilute and use promptly. DISCARD BAG WITHIN 4 HOURS AFTER INITIAL ENTRY. See package insert for full information.

THIS PHARMACY BULK PACKAGE IS INTENDED FOR PREPARING MANY SINGLE DOSES IN A PHARMACY ADMIXTURE PROGRAM.

Approximate Concentration	Amount of Sterile Water for Injection
1 gram/10 mL	875 mL

See package insert for detailed constitution, final dilution, and administration instructions. Protect from light: THE INNER BAG SHOULD BE RETAINED IN THE OUTER BAG UNTIL TIME OF USE.

SmartPak system components are not made with natural rubber latex.

Date entered _____
Time of entry _____
Discard within 4 hours

Manufactured in Italy for Samson Medical Technologies, L.L.C.
Cherry Hill, NJ 08003

Product No. 8100
A8100

Cefepime for Injection, USP**100** grams [ONE HUNDRED GRAMS] per Pharmacy Bulk Package Bag**PHARMACY BULK PACKAGE -
NOT FOR DIRECT INFUSION**FOR INTRAVENOUS USE ONLY
NOT TO BE DISPENSED AS A UNIT

Rx Only

IMPORTANT: READ PACKAGE INSERT FOR PRECAUTIONS AND DIRECTIONS FOR USE. AFTER CONSTITUTION, MUST BE FURTHER DILUTED.

Sterile, Nonpyrogenic, Preservative-Free

Each 100 gram Pharmacy Bulk Package contains sterile cefepime hydrochloride equivalent to 100 grams of cefepime and L-arginine for pH adjustment.

USUAL DOSAGE: See package insert.

Prior to constitution, store dry powder at 20° to 25°C (68° to 77°F).

[see USP Controlled Room Temperature.]

After constitution, dilute and use promptly. **DISCARD BAG WITHIN 4 HOURS AFTER INITIAL ENTRY.** See package insert for full information.**THIS PHARMACY BULK PACKAGE IS INTENDED FOR PREPARING MANY SINGLE DOSES IN A PHARMACY ADMIXTURE PROGRAM.**

Approximate Concentration	Amount of Sterile Water for Injection
1 gram/10 mL	875 mL

See package insert for detailed constitution, final dilution, and administration instructions. Protect from light: **THE INNER BAG SHOULD BE RETAINED IN THE OUTER BAG UNTIL TIME OF USE.**

SmartPak system components are not made with natural rubber latex.

Manufactured in Italy for:

SAMSON™
MEDICAL TECHNOLOGIES, L.L.C.

Cherry Hill, NJ 08003

Date of Entry: _____
Time of Entry: _____ (AM/PM)
DISCARD 4 HOURS AFTER INITIAL ENTRYProduct No. 8100
A8100**CEFEPIME**

cefepime injection, powder, for solution

Product Information

Product Type	HUMAN PRESCRIPTION DRUG	Item Code (Source)	NDC:66288-8100
Route of Administration	INTRAVENOUS		

Active Ingredient/Active Moiety

Ingredient Name		Basis of Strength	Strength	
CEFEPIME HYDROCHLORIDE (UNII: I8X1O0607P) (CEFEPIME - UNII:807PW4VQE3)		CEFEPIME	100 g	
Inactive Ingredients				
Ingredient Name		Strength		
ARGININE (UNII: 94ZLA3W45F)				
Packaging				
#	Item Code	Package Description	Marketing Start Date	Marketing End Date
1	NDC:66288-8100-1	1 in 1 BAG	10/01/2018	
1		1 in 1 BAG; Type 0: Not a Combination Product		
Marketing Information				
Marketing Category	Application Number or Monograph Citation	Marketing Start Date	Marketing End Date	
ANDA	ANDA209408	10/01/2018		

Labeler - SAMSON MEDICAL TECHNOLOGIES LLC (102837429)

Revised: 1/2022

SAMSON MEDICAL TECHNOLOGIES LLC