

HYDRATING FACIAL CREAM SPF 15 DRY SKIN- ethylhexyl methoxycinnamate, butyl methoxydibenzoylmethane, benzophenone-3 cream
BALM WITH NATURAL BUTTERS SPF15- octinoxate lipstick
EYELASH AND EYEBROW LENGTHENER- propylene glycol cream
FACIAL PRIMER PROTECTOR SPF 50- homosalate cream
HYDRATING FACIAL SPF 15 MIX NORMAL SKIN- octinoxate cream
ULTRA LIGHT FACIAL SUNSCREEN SPF 50- octocrylene cream
ANTI LOSS TREATMENT TERRAMAR- 3-hexyloxypropylene glycol cream
ANTILOSS TERRAMAR SH- propylene glycol 1 - oleate cream
SKIN RECOVERY FACE SPF 15- octinoxate cream
MATTIFYING FACIAL SPF 15 OILY SKIN- octinoxate cream
BODY SUNSCREEN FPS 50- octocrylene, homosalate, butyl methoxydibenzoylmethane, ethylhexyl salicylate, 4-methylbenzylidene camphor cream
PROTECTIVE MAKEUP SPF 15 WITH EDELWESS STEM CELLS- ethylhexyl methoxycinnamate, benzophenone-3 cream
MAQUILLAJE LIQUIDO MAXIMA COBERTURA- ethylhexyl methoxycinnamate, benzophenone-3 cream
MATURE SKIN FACIAL DAY SPF 15- ethylhexyl methoxycinnamate, titanium dioxide, silica, dimethicone cream
COLOR CORRECTING SPF 20- ethylhexyl methoxycinnamate, octocrylene, butyl methoxydibenzoylmethane cream
SUN PROTECTION FACIAL SPF 50- homosalate, neo heliopan, ethylhexyl salicylate, benzophenone-3, octocrylene, avovenzona (butyl methoxydibenzoylmethane), titanium dioxide ci 77891 cream
ANTI HAIR LOSS GEL WITH ARNICA, ROSEMARY, AND LEMON EXTRACTS.- propylene glycol gel
DESODORANTE ANTIPERSPIRANT- aluminium chlorohydrate aerosol, spray
FACIAL PRIMER PROTECTOR SPF 50- homosalate, benzophenone-3, octocrylene, ethylhexyl salicylate, butyl methoxydibenzoylmethane cream
FOCUSED CORRECTIVE- water (aqua), butylene glycol, peg-60 almond glycerides, caprylyl glycol, glycerin, carbomer, nordihydroguaiaretic acid, oleanolic acid, beta vulgaris (beet) root extract, oenothera biennis (evening primrose) leaf extract cream
TERRAMAR BRANDS S de RL de CV

Disclaimer: Most OTC drugs are not reviewed and approved by FDA, however they may be marketed if they comply with applicable regulations and policies. FDA has not evaluated whether this product complies.

TERRAMAR BRANDS - SUNSCREEN PRODUCTS

51945-4

Drug Facts

Active Ingredients

Butylene Glycol (and) Aqua (and) PPG-26-Buteth-26 (and) PEG-40 Hydrogenated Castor Oil (and) Apigenin (and) Oleanolic Acid (and) Biotinoyl Tripeptide-1 /// 3%

Water (Aqua), Glycerin, Alcohol, Sodium PCA, Sodium Lactate, Arginine, Aspartic Acid, Pca, Glycine, Alanine, Serine, Valine, Proline, Threonine, Isoleucine, Histidine, Phenylalanine, Hedicago Sativa (AFAFA) Extract, Humulus Lupulus (Hops) Extract, Rosmarinus Officinalis (Rosemary) Extract, Helibcus Officinalis Extract. /// 2%

Propylene Glycol, Aqua, Rosmarinus Officinalis (Rosemary) Leaf Extract, Chamomilla Recutita (Matricaria) Flower Extract, Arnica Montana Flower Extract, Lamium Album Extract, Salvia Officinalis (Sage) Leaf Extract, Pinus Sylvestris Bud Extract, Nasturtium Officinale Extract, Actium Majus Root Extract, Citrus Medica Limonum (Lemon) Peel Extract, Hedera Helix (Ivy) Leaf Extract, Calendula Officinalis Flower Extract, Tropaeolum Majus Flower Extract. /// 0.20%

Uses

Anti hair loss treatment

Warnings

Ask a doctor if:

For external use.

May cause eye irritation. Discontinue use if irritation or rash occurs.

If pregnant or breast-feeding, ask a health professional before use.

Keep out of reach of children.

Directions

Apply as needed

Other Information

Store at room temperature

Inactive Ingredients

Listed in front label.

Questions or comments?

800-313-0903

customerservice@tmbrandsusa.com

Drug Facts



Active Ingredients

Butylene Glycol (and) Aqua (and) PPG-26-Buteth-26 (and) PEG-40 Hydrogenated Castor Oil (and) Apigenin (and) Oleoic Acid (and) Biotinyl Tripeptide-1 /// 3%

Water (Aqua), Glycerin, Alcohol, Sodium PCA, Sodium Lactate, Arginine, Aspartic Acid, Pca, Glycine, Alanine, Serine, Valine, Proline, Threonine, Isoleucine, Histidine, Phenylalanine, Medicago Sativa (Alfalfa) Extract, Humulus Lupulus (Hops) Extract, Rosmarinus Officinalis (Rosemary) Extract, Helibolus Officinalis Extract. /// 2%

Propylene Glycol, Aqua, Rosmarinus Officinalis (Rosemary) Leaf Extract, Chamomilla Recutita (Matricaria) Flower Extract, Arnica Montana Flower Extract, Lamium Album Extract, Salvia Officinalis (Sage) Leaf Extract, Pinus Sylvestris Bud Extract, Nasturtium Officinale Extract, Actium Hagus Root Extract, Citrus Medica Limonum (Lemon) Peel Extract, Hedera Helix (Ivy) Leaf Extract, Calendula Officinalis Flower Extract, Tropaeolum Hagus Flower Extract. /// 0.20%

Uses

Anti hair loss treatment

Warnings

Ask a doctor if:

For external use.

May cause eye irritation. Discontinue use if irritation or rash occurs.

If pregnant or breast-feeding, ask a health professional before use.

Keep out of reach of children.

Directions

Apply as needed

Other Information

Store at room temperature

Inactive Ingredients

Listed in front label.

Questions or comments?

800-313-0903

customerservice@tmbrandsusa.com

51945-4

51945-4

Drug Facts

Active Ingredients

Butylene Glycol (and) Aqua (and) PEG-26-Buteth-26 (and) PEG-40 Hydrogenated Castor Oil (and) Apigenin (and) Oleoic Acid (and) Botanoyl Tripeptide-1 /// 3%

Water (Aqua), Glycerin, Alcohol, Sodium PCA, Sodium Lactate, Arginine, Aspartic Acid, Pca, Glycine, Alanine, Serine, Valine, Proline, Threonine, Isoleucine, Histidine, Phenylalanine, Hedicago Sativa (AFAFA) Extract, Humulus Lupulus (Hops) Extract, Rosmarinus Officinalis (Rosemary) Extract, Helictus Officinalis Extract. /// 2%

Propylene Glycol, Aqua, Rosmarinus Officinalis (Rosemary) Leaf Extract, Chamomilla Recutita (Matricaria) Flower Extract, Arnica Montana Flower Extract, Lamium Album Extract, Salvia Officinalis (Sage) Leaf Extract, Pinus Sylvestris Bud Extract, Nasturtium Officinale Extract, Actium Majus Root Extract, Citrus Medica Limonum (Lemon) Peel Extract, Hedera Helix (Ivy) Leaf Extract, Calendula Officinalis Flower Extract, Tropaeolum Majus Flower Extract. /// 0.20%

Uses

Anti hair loss treatment

Warnings

Ask a doctor if:

For external use.

May cause eye irritation. Discontinue use if irritation or rash occurs.

If pregnant or breast-feeding, ask a health professional before use.

Keep out of reach of children.

Directions

Apply as needed

Other Information

Store at room temperature

Inactive Ingredients

Listed in front label.

Questions or comments?

800-313-0903

customerservice@tmbrandsusa.com

51945-

51945-4

Drug Facts

Active Ingredients

Butylene Glycol (and) Aqua (and) PPG-26-Buteth-26 (and) PEG-40 Hydrogenated Castor Oil (and) Apigenin (and) Oleoic Acid (and) Botinoyl Tripeptide-1 /// 3%

Water (Aqua), Glycerin, Alcohol, Sodium PCA, Sodium Lactate, Arginine, Aspartic Acid, Pca, Glycine, Alanine, Serine, Valine, Proline, Threonine, Isoleucine, Histidine, Phenylalanine, Medicago Sativa (Alfalfa) Extract, Humulus Lupulus (Hops) Extract, Rosmarinus Officinalis (Rosemary) Extract, Heliotropium Officinale Extract. /// 2%

Propylene Glycol, Aqua, Rosmarinus Officinalis (Rosemary) Leaf Extract, Cinnamomum Cassia (Cassia) Flower Extract, Arnica Montana Flower Extract, Lamium Album Extract, Salvia Officinalis (Sage) Leaf Extract, Pinus Sylvestris Bud Extract, Nasturtium Officinale Extract, Arctium Lappa Root Extract, Citrus Medica Limonum (Lemon) Peel Extract, Hedera Helix (Ivy) Leaf Extract, Calendula Officinalis Flower Extract, Tropaeolum Majus Flower Extract. /// 0.20%

Uses

Anti hair loss treatment

Warnings

Ask a doctor if:

For external use.

May cause eye irritation. Discontinue use if irritation or rash occurs.

If pregnant or breast-feeding, ask a health professional before use.

Keep out of reach of children.

Directions

Apply as needed

Other Information

Store at room temperature

Inactive Ingredients

Listed in front label.

Questions or comments?

800-313-0903

customerservice@tmbrandsusa.com

51945-

51945-4

Drug Facts

Active Ingredients

Butylene Glycol (and) Aqua (and) PPG-26-Buteth-26 (and) PEG-40 Hydrogenated Castor Oil (and) Apigenin (and) Oleoic Acid (and) Botinoyl Tripeptide-1 /// 3%

Water (Aqua), Glycerin, Alcohol, Sodium PCA, Sodium Lactate, Arginine, Aspartic Acid, Pca, Glycine, Alanine, Serine, Valine, Proline, Threonine, Isoleucine, Histidine, Phenylalanine, Medicago Sativa (Alfalfa) Extract, Humulus Lupulus (Hops) Extract, Rosmarinus Officinalis (Rosemary) Extract, Helibcus Officinalis Extract. /// 2%

Propylene Glycol, Aqua, Rosmarinus Officinalis (Rosemary) Leaf Extract, Chamomilla Recutita (Matricaria) Flower Extract, Arnica Montana Flower Extract, Lamium Album Extract, Salvia Officinalis (Sage) Leaf Extract, Pinus Sylvestris Bud Extract, Nasturtium Officinale Extract, Actium Majus Root Extract, Citrus Medica Limonum (Lemon) Peel Extract, Hedera Helix (Ivy) Leaf Extract, Calendula Officinalis Flower Extract, Tropaeolum Majus Flower Extract. /// 0.20%

Uses

Anti hair loss treatment

Warnings

Ask a doctor if:

For external use.

May cause eye irritation. Discontinue use if irritation or rash occurs.

If pregnant or breast-feeding, ask a health professional before use.

Keep out of reach of children.

Directions

Apply as needed

Other Information

Store at room temperature

Inactive Ingredients

Listed in front label.

Questions or comments?

800-313-0903
customerservice@tmbrandsusa.com

51945-4

51945-4

Drug Facts

Active Ingredients

Butylene Glycol (and) Aqua (and) PPG-26-Buteth-26 (and) PEG-40 Hydrogenated Castor Oil (and) Apigenin (and) Oleoic Acid (and) Bioinoyl Tripeptide-1 /// 3%

Water (Aqua), Glycerin, Alcohol, Sodium PCA, Sodium Lactate, Arginine, Aspartic Acid, Pca, Glycine, Alanine, Serine, Valine, Proline, Threonine, Isoleucine, Histidine, Phenylalanine, Medicago Sativa (Alfalfa) Extract, Humulus Lupulus (Hops) Extract, Rosmarinus Officinalis (Rosemary) Extract, Helibulus Officinalis Extract. /// 2%

Propylene Glycol, Aqua, Rosmarinus Officinalis (Rosemary) Leaf Extract, Chamomilla Recutita (Matricaria) Flower Extract, Arnica Montana Flower Extract, Lamium Album Extract, Salvia Officinalis (Sage) Leaf Extract, Pinus Sylvestris Bud Extract, Nasturtium Officinale Extract, Actium Majus Root Extract, Citrus Medica Limonum (Lemon) Peel Extract, Hedera Helix (Ivy) Leaf Extract, Calendula Officinalis Flower Extract, Tropaeolum Majus Flower Extract. /// 0.20%

Uses

Anti hair loss treatment

Warnings

Ask a doctor if:

For external use.

May cause eye irritation. Discontinue use if irritation or rash occurs.

If pregnant or breast-feeding, ask a health professional before use.

Keep out of reach of children.

Directions

Apply as needed

Other Information

Store at room temperature

Inactive Ingredients

Listed in front label.

Questions or comments?

800-313-0903

customerservice@tmbrandsusa.com

51945-4

51945-4

Drug Facts

Active Ingredients

Butylene Glycol (and) Aqua (and) PPG-26-Buteth-26 (and) PEG-40 Hydrogenated Castor Oil (and) Apigenin (and) Oleoic Acid (and) Biotinyl Tripeptide-1 /// 3%

Water (Aqua), Glycerin, Alcohol, Sodium PCA, Sodium Lactate, Arginine, Aspartic Acid, Pca, Glycine, Alanine, Serine, Valine, Proline, Threonine, Isoleucine, Histidine, Phenylalanine, Medicago Sativa (Alfalfa) Extract, Humulus Lupulus (Hops) Extract, Rosmarinus Officinalis (Rosemary) Extract, Helibcus Officinalis Extract /// 2%

Propylene Glycol, Aqua, Rosmarinus Officinalis (Rosemary) Leaf Extract, Chamomilla Recutita (Matricaria) Flower Extract, Arnica Montana Flower Extract, Lamium Album Extract, Salvia Officinalis (Sage) Leaf Extract, Pinus Sylvestris Bud Extract, Nasturium Officinale Extract, Actium Majus Root Extract, Citrus Medica Limonum (Lemon) Peel Extract, Hedera Helix (Ivy) Leaf Extract, Calendula Officinalis Flower Extract, Tropaeolum Majus Flower Extract /// 0.20%

Uses

Anti hair loss treatment

Warnings

Ask a doctor if:

For external use.

May cause eye irritation. Discontinue use if irritation or rash occurs.

If pregnant or breast-feeding, ask a health professional before use.

Keep out of reach of children.

Directions

Apply as needed

Other Information

Store at room temperature

Inactive Ingredients

Listed in front label.

Questions or comments?

800-313-0903

customerservice@tmbrandsusa.com

51945-4

Drug Facts

Active Ingredients

Butylene Glycol (and) Aqua (and) PPG-26-Buteth-26 (and) PEG-40 Hydrogenated Castor Oil (and) Apigenin (and) Oleoic Acid (and) Bis(2-Ethylhexyl) Tripropylene Glycol // 3%

Water (Aqua), Glycerin, Alcohol, Sodium PCA, Sodium Lactate, Arginine, Aspartic Acid, Pca, Glycine, Alanine, Serine, Valine, Proline, Threonine, Isoleucine, Histidine, Phenylalanine, Medicago Sativa (Alfalfa) Extract, Humulus Lupulus (Hops) Extract, Rosmarinus Officinalis (Rosemary) Extract, Helibolus Officinalis Extract. // 2%

Propylene Glycol, Aqua, Rosmarinus Officinalis (Rosemary) Leaf Extract, Chamomilla Recutita (Matricaria) Flower Extract, Arnica Montana Flower Extract, Lamium Album Extract, Salvia Officinalis (Sage) Leaf Extract, Pinus Sylvestris Bud Extract, Nasturium Officinale Extract, Actium Majus Root Extract, Citrus Medica Limonum (Lemon) Peel Extract, Hedera Helix (Ivy) Leaf Extract, Calendula Officinalis Flower Extract, Tropaeolum Majus Flower Extract. // 0.20%

Uses

Anti hair loss treatment

Warnings

Ask a doctor if:

For external use.

May cause eye irritation. Discontinue use if irritation or rash occurs.

If pregnant or breast-feeding, ask a health professional before use.

Keep out of reach of children.

Directions

Apply as needed

Other Information

OTHER INFORMATION

Store at room temperature

Inactive Ingredients

Listed in front label.

Questions or comments?

800-313-0903

customerservice@tmbrandsusa.com

51945-4

Drug Facts

Active Ingredients

Butylene Glycol (and) Aqua (and) PPG-26-Buteth-26 (and) PEG-40 Hydrogenated Castor Oil (and) Apigenin (and) Oleoic Acid (and) Biotinoyl Tripeptide-1 /// 3%

Water (Aqua), Glycerin, Alcohol, Sodium PCA, Sodium Lactate, Arginine, Aspartic Acid, Pca, Glycine, Alanine, Serine, Valine, Proline, Threonine, Isoleucine, Histidine, Phenylalanine, Medicago Sativa (Alfalfa) Extract, Humulus Lupulus (Hops) Extract, Rosmarinus Officinalis (Rosemary) Extract, Helibcus Officinalis Extract. /// 2%

Propylene Glycol, Aqua, Rosmarinus Officinalis (Rosemary) Leaf Extract, Chamomilla Recutita (Matricaria) Flower Extract, Arnica Montana Flower Extract, Lamium Album Extract, Salvia Officinalis (Sage) Leaf Extract, Pinus Sylvestris Bud Extract, Nasturtium Officinale Extract, Actium Majus Root Extract, Citrus Medica Limonum (Lemon) Peel Extract, Hedera Helix (Ivy) Leaf Extract, Calendula Officinalis Flower Extract, Tropaeolum Majus Flower Extract. /// 0.20%

Uses

Anti hair loss treatment

Warnings

Ask a doctor if:

For external use.

May cause eye irritation. Discontinue use if irritation or rash occurs.

If pregnant or breast-feeding, ask a health professional before use.

Keep out of reach of children.

Directions

Apply as needed

Other Information

Store at room temperature

Inactive Ingredients

Listed in front label.

Questions or comments?

800-313-0903

customerservice@tmbrandsusa.com

Drug Facts

Active Ingredients

Butylene Glycol (and) Aqua (and) PPG-26-Buteth-26 (and) PEG-40 Hydrogenated Castor Oil (and) Apigenin (and) Oleanoic Acid (and) BioGlycerylTripeptide-1 /// 3%

Water (Aqua), Glycerin, Alcohol, Sodium PCA, Sodium Lactate, Arginine, Aspartic Acid, Pca, Glycine, Alanine, Serine, Valine, Proline, Threonine, Isoleucine, Histidine, Phenylalanine, Medicago Sativa (Alfalfa) Extract, Humulus Lupulus (Hops) Extract, Rosmarinus Officinalis (Rosemary) Extract, Helibolus Officinalis Extract. /// 2%

Propylene Glycol, Aqua, Rosmarinus Officinalis (Rosemary) Leaf Extract, Chamomilla Recutita (Matricaria) Flower Extract, Arnica Montana Flower Extract, Lamium Album Extract, Salvia Officinalis (Sage) Leaf Extract, Pinus Sylvestris Bud Extract, Nasturtium Officinale Extract, Actium Majus Root Extract, Citrus Medica Limonum (Lemon) Peel Extract, Hedera Helix (Ivy) Leaf Extract, Calendula Officinalis Flower Extract, Tropaeolum Majus Flower Extract. /// 0.20%

Uses

Anti hair loss treatment

Warnings

Ask a doctor if:

For external use.

May cause eye irritation. Discontinue use if irritation or rash occurs.

If pregnant or breast-feeding, ask a health professional before use.

Keep out of reach of children.

Directions

Apply as needed

Other Information

Store at room temperature

Inactive Ingredients

Listed in front label.

Questions or comments?

800-313-0903

customerservice@tmbrandsusa.com

Drug Facts

Active Ingredients

Butylene Glycol (and) Aqua (and) PPG-26-Buteth-26 (and) PEG-40 Hydrogenated Castor Oil (and) Apigenin (and) Oleoic Acid (and) Biotinyl Tripeptide-1 /// 3%

Water (Aqua), Glycerin, Alcohol, Sodium PCA, Sodium Lactate, Arginine, Aspartic Acid, Pca, Glycine, Alanine, Serine, Valine, Proline, Threonine, Isoleucine, Histidine, Phenylalanine, Medicago Sativa (Alfalfa) Extract, Humulus Lupulus (Hops) Extract, Rosmarinus Officinalis (Rosemary) Extract, Heliotus Officinalis Extract. /// 2%

Propylene Glycol, Aqua, Rosmarinus Officinalis (Rosemary) Leaf Extract, Chamomilla Recutita (Matricaria) Flower Extract, Arnica Montana Flower Extract, Lamium Album Extract, Salvia Officinalis (Sage) Leaf Extract, Pinus Sylvestris Bud Extract, Nasturtium Officinale Extract, Actinum Majus Root Extract, Citrus Medica Limonum (Lemon) Peel Extract, Hedera Helix (Ivy) Leaf Extract, Calendula Officinalis Flower Extract, Tropaeolum Majus Flower Extract. /// 0.20%

Uses

Anti hair loss treatment

Warnings

Ask a doctor if:

For external use.

May cause eye irritation. Discontinue use if irritation or rash occurs.

If pregnant or breast-feeding, ask a health professional before use.

Keep out of reach of children.

Directions

Apply as needed

Other Information

Store at room temperature

Inactive Ingredients

Listed in front label.

Questions or comments?

800-313-0903

customerservice@tmbrandsusa.com

Drug Facts

Active Ingredients

Butylene Glycol (and) Aqua (and) PPG-26-Buteth-26 (and) PEG-40 Hydrogenated Castor Oil (and) Apigenin (and) Oleoic Acid (and) Biotinyl Tripeptide-1 /// 3%

Water (Aqua), Glycerin, Alcohol, Sodium PCA, Sodium Lactate, Arginine, Aspartic Acid, Pca, Glycine, Alanine, Serine, Valine, Proline, Threonine, Isoleucine, Histidine, Phenylalanine, Medicago Sativa (Alfalfa) Extract, Humulus Lupulus (Hops) Extract, Rosmarinus Officinalis (Rosemary) Extract, Helibcus Officinalis Extract /// 2%

Propylene Glycol, Aqua, Rosmarinus Officinalis (Rosemary) Leaf Extract, Chamomilla Recutita (Matricaria) Flower Extract, Arnica Montana Flower Extract, Lamium Album Extract, Salvia Officinalis (Sage) Leaf Extract, Pinus Sylvestris Bud Extract, Nasturtium Officinale Extract, Actium Majus Root Extract, Citrus Medica Limonum (Lemon) Peel Extract, Hedera Helix (Ivy) Leaf Extract, Calendula Officinalis Flower Extract, Tropaeolum Majus Flower Extract /// 0.20%

Uses

Anti hair loss treatment

Warnings

Ask a doctor if:

For external use.

May cause eye irritation. Discontinue use if irritation or rash occurs.

If pregnant or breast-feeding, ask a health professional before use.

Keep out of reach of children.

Directions

Directions

Apply as needed

Other Information

Store at room temperature

Inactive Ingredients

Listed in front label.

Questions or comments?

800-313-0903

customerservice@tmbrandsusa.com

Drug Facts

Active Ingredients

Butylene Glycol (and) Aqua (and) PPG-26-Buteth-26 (and) PEG-40 Hydrogenated Castor Oil (and) Apigenin (and) Oleoic Acid (and) Botinoyl Tripeptide-1 /// 3%

Water (Aqua), Glycerin, Alcohol, Sodium PCA, Sodium Lactate, Arginine, Aspartic Acid, Pca, Glycine, Alanine, Serine, Valine, Proline, Threonine, Isoleucine, Histidine, Phenylalanine, Medicago Sativa (Alfalfa) Extract, Humulus Lupulus (Hops) Extract, Rosmarinus Officinalis (Rosemary) Extract, Helibcus Officinalis Extract. /// 2%

Propylene Glycol, Aqua, Rosmarinus Officinalis (Rosemary) Leaf Extract, Chamomilla Recutita (Matricaria) Flower Extract, Arnica Montana Flower Extract, Lamium Album Extract, Salvia Officinalis (Sage) Leaf Extract, Pinus Sylvestris Bud Extract, Nasturtium Officinale Extract, Actium Majus Root Extract, Citrus Medica Limonum (Lemon) Peel Extract, Hedera Helix (Ivy) Leaf Extract, Calendula Officinalis Flower Extract, Tropaeolum Majus Flower Extract. /// 0.20%

Uses

Anti hair loss treatment

Warnings

Ask a doctor if:

For external use.

May cause eye irritation. Discontinue use if irritation or rash occurs.

If pregnant or breast-feeding, ask a health professional before use.

Keep out of reach of children.

Directions

Apply as needed

Other Information

Store at room temperature

Inactive Ingredients

Listed in front label.

Questions or comments?

800-313-0903

customerservice@tmbrandsusa.com

51945-4

Drug Facts

Active Ingredients

Butylene Glycol (and) Aqua (and) PPG-26-Buteth-26 (and) PEG-40 Hydrogenated Castor Oil (and) Apigenin (and) Oleoic Acid (and) Bioinoyl Tripeptide-1 /// 3%

Water (Aqua), Glycerin, Alcohol, Sodium PCA, Sodium Lactate, Arginine, Aspartic Acid, Pca, Glycine, Alanine, Serine, Valine, Proline, Threonine, Isoleucine, Histidine, Phenylalanine, Medicago Sativa (Alfalfa) Extract, Humulus Lupulus (Hops) Extract, Rosmarinus Officinalis (Rosemary) Extract, Heliotropium Officinale Extract. /// 2%

Propylene Glycol, Aqua, Rosmarinus Officinalis (Rosemary) Leaf Extract, Chamomilla Recutita (Matricaria) Flower Extract, Arnica Montana Flower Extract, Lamium Album Extract, Salvia Officinalis (Sage) Leaf Extract, Pinus Sylvestris Bud Extract, Nasturtium Officinale Extract, Actinum Majus Root Extract, Citrus Medica Limonum (Lemon) Peel Extract, Hedera Helix (Ivy) Leaf Extract, Calendula Officinalis Flower Extract, Tropaeolum Majus Flower Extract. /// 0.20%

Uses

Anti hair loss treatment

Warnings

Ask a doctor if:

For external use.

May cause eye irritation. Discontinue use if irritation or rash occurs.

may cause eye irritation. Discontinue use if irritation or rash occurs.
If pregnant or breast-feeding, ask a health professional before use.
Keep out of reach of children.

Directions

Apply as needed

Other Information

Store at room temperature

Inactive Ingredients

Listed in front label.

Questions or comments?

800-313-0903
customerservice@tmbrandsusa.com

Drug Facts

Active Ingredients

Butylene Glycol (and) Aqua (and) PPG-26-Buteth-26 (and) PEG-40 Hydrogenated Castor Oil (and) Apigenin (and) Oleanolic Acid (and) Botanoyl Tripeptide-1 /// 3%

Water (Aqua), Glycerin, Alcohol, Sodium PCA, Sodium Lactate, Arginine, Aspartic Acid, Pca, Glycine, Alanine, Serine, Valine, Proline, Threonine, Isoleucine, Histidine, Phenylalanine, Medicago Sativa (Alfalfa) Extract, Humulus Lupulus (Hops) Extract, Rosmarinus Officinalis (Rosemary) Extract, Helibctus Officinalis Extract /// 2%

Propylene Glycol, Aqua, Rosmarinus Officinalis (Rosemary) Leaf Extract, Chamomilla Recutita (Matricaria) Flower Extract, Arnica Montana Flower Extract, Lamium Album Extract, Salvia Officinalis (Sage) Leaf Extract, Pinus Sylvestris Bud Extract, Nasturtium Officinale Extract, Actium Majus Root Extract, Citrus Medica Limonum (Lemon) Peel Extract, Hedera Helix (Ivy) Leaf Extract, Calendula Officinalis Flower Extract, Tropaeolum Majus Flower Extract /// 0.20%

Uses

Anti hair loss treatment

Warnings

Ask a doctor if:

For external use.

May cause eye irritation. Discontinue use if irritation or rash occurs.

If pregnant or breast-feeding, ask a health professional before use.

Keep out of reach of children.

Directions

Apply as needed

Other Information

Store at room temperature

Inactive Ingredients

Listed in front label.

Questions or comments?

800-313-0903

customerservice@tmbrandsusa.com

DRUG FACTS

ACTIVE INGREDIENTS

Drug Facts

Active Ingredients

Butylene Glycol (and) Aqua (and) PEG-26-Buteth-26 (and) PEG-40 Hydrogenated Castor Oil (and) Apigenin (and) Oleanolic Acid (and) Bis(Octyl)Tripeptide-1 /// 3%

Water (Aqua), Glycerin, Alcohol, Sodium PCA, Sodium Lactate, Arginine, Aspartic Acid, Pca, Glycine, Alanine, Serine, Valine, Proline, Threonine, Isoleucine, Histidine, Phenylalanine, Medicago Sativa (Alfalfa) Extract, Humulus Lupulus (Hops) Extract, Rosmarinus Officinalis (Rosemary) Extract, Helictus Officinalis Extract. /// 2%

Propylene Glycol, Aqua, Rosmarinus Officinalis (Rosemary) Leaf Extract, Chamomilla Recutita (Matricaria) Flower Extract, Arnica Montana Flower Extract, Lamium Album Extract, Salvia Officinalis (Sage) Leaf Extract, Pinus Sylvestris Bud Extract, Nasturtium Officinale Extract, Actium Majus Root Extract, Citrus Medica Limonum (Lemon) Peel Extract, Hedera Helix (Ivy) Leaf Extract, Calendula Officinalis Flower Extract, Tropaeolum Majus Flower Extract. /// 0.20%

Uses

Anti hair loss treatment

Warnings

Ask a doctor if:

For external use.

May cause eye irritation. Discontinue use if irritation or rash occurs.

If pregnant or breast-feeding, ask a health professional before use.

Keep out of reach of children.

Directions

Apply as needed

Other Information

Store at room temperature

Inactive Ingredients

Listed in front label.

Questions or comments?

800-313-0903

customerservice@tmbrandsusa.com

ask a doctor if:

Drug Facts

Active Ingredients

Butylene Glycol (and) Aqua (and) PPG-26-Buteth-26 (and) PEG-40 Hydrogenated Castor Oil (and) Apigenin (and) Oleanolic Acid (and) Bioinoyl Tripeptide-1 /// 3%

Water (Aqua), Glycerin, Alcohol, Sodium PCA, Sodium Lactate, Arginine, Aspartic Acid, Pca, Glycine, Alanine, Serine, Valine, Proline, Threonine, Isoleucine, Histidine, Phenylalanine, Medicago Sativa (AlfaFa) Extract, Humulus Lupulus (Hops) Extract, Rosmarinus Officinalis (Rosemary) Extract, Heliotus Officinalis Extract. /// 2%

Propylene Glycol, Aqua, Rosmarinus Officinalis (Rosemary) Leaf Extract, Chamomilla Recutita (Matricaria) Flower Extract, Arnica Montana Flower Extract, Lamium Album Extract, Salvia Officinalis (Sage) Leaf Extract, Pinus Sylvestris Bud Extract, Nasturtium Officinale Extract, Actium Hajas Root Extract, Citrus Medica Limonum (Lemon) Peel Extract, Hedera Helix (Ivy) Leaf Extract, Calendula Officinalis Flower Extract, Tropaeolum Hajas Flower Extract. /// 0.20%

Uses

Anti hair loss treatment

Warnings

Ask a doctor if:

For external use.

May cause eye irritation. Discontinue use if irritation or rash occurs.

If pregnant or breast-feeding, ask a health professional before use.

Keep out of reach of children.

Directions

Apply as needed

Other Information

Store at room temperature

Inactive Ingredients

Listed in front label.

Questions or comments?

800-313-0903

customerservice@tmbrandsusa.com

symptoms

Drug Facts

Active Ingredients

Butylene Glycol (and) Aqua (and) PPG-26-Buteth-26 (and) PEG-40 Hydrogenated Castor Oil (and) Apigenin (and) Oleic Acid (and) Biotinyl Tripeptide-1 /// 3%

Water (Aqua), Glycerin, Alcohol, Sodium PCA, Sodium Lactate, Arginine, Aspartic Acid, Pca, Glycine, Alanine, Serine, Valine, Proline, Threonine, Isoleucine, Histidine, Pteryls lanine, Medicago Sativa (Alfalfa) Extract, Humulus Lupulus (Hops) Extract, Rosmarinus Officinalis (Rosemary) Extract, Heliclus Officinalis Extract. /// 2%

Propylene Glycol, Aqua, Rosmarinus Officinalis (Rosemary) Leaf Extract, Chamomilla Recutita (Matricaria) Flower Extract, Arnica Montana Flower Extract, Lamium Album Extract, Salvia Officinalis (Sage) Leaf Extract, Pinus Sylvestris Bud Extract, Nasturium Officinale Extract, Actium Majus Root Extract, Citrus Medica Limonum (Lemon) Peel Extract, Hedera Helix (Ivy) Leaf Extract, Calendula Officinalis Flower Extract, Tropaeolum Majus Flower Extract. /// 0.20%

Uses

Anti hair loss treatment

Warnings

Ask a doctor if:

For external use.

May cause eye irritation. Discontinue use if irritation or rash occurs.

If pregnant or breast-feeding, ask a health professional before use.

Keep out of reach of children.

Directions

Apply as needed

Other Information

Store at room temperature

Inactive Ingredients

Listed in front label.

Questions or comments?

800-313-0903

customerservice@tmbrandsusa.com

do not use if

keep out of reach of children

Drug Facts

Active Ingredients

Butylene Glycol (and) Aqua (and) PPG-26-Buteth-26 (and) PEG-40 Hydrogenated Castor Oil (and) Apigenin (and) Oleoic Acid (and) Botanoyl Tripeptide-1 /// 3%

Water (Aqua), Glycerin, Alcohol, Sodium PCA, Sodium Lactate, Arginine, Aspartic Acid, Pca, Glycine, Alanine, Serine, Valine, Proline, Threonine, Isoleucine, Histidine, Phenylalanine, Medicago Sativa (Alfalfa) Extract, Humulus Lupulus (Hops) Extract, Rosmarinus Officinalis (Rosemary) Extract, Helictus Officinalis Extract. /// 2%

Propylene Glycol, Aqua, Rosmarinus Officinalis (Rosemary) Leaf Extract, Chamomilla Recutita (Matricaria) Flower Extract, Arnica Montana Flower Extract, Lamium Album Extract, Salvia Officinalis (Sage) Leaf Extract, Pinus Sylvestris Bud Extract, Nasturtium Officinale Extract, Actium Maius Root Extract, Citrus Medica Limonum (Lemon) Peel Extract, Hedera Helix

Uses

Anti hair loss treatment

Warnings

Ask a doctor if:

For external use.

May cause eye irritation. Discontinue use if irritation or rash occurs.

If pregnant or breast-feeding, ask a health professional before use.

Keep out of reach of children.

Directions

Apply as needed

Other Information

Store at room temperature

Inactive Ingredients

Listed in front label.

Questions or comments?

800-313-0903

customerservice@tmbrandsusa.com

If pregnant or breast-feeding, ask a health

Drug Facts

Active Ingredients

Butylene Glycol (and) Aqua (and) PPG-26-Buteth-26 (and) PEG-40 Hydrogenated Castor Oil (and) Apigenin (and) Oleanolic Acid (and) Bioflavonoid Tripeptide-1 /// 3%

Water (Aqua), Glycerin, Alcohol, Sodium PCA, Sodium Lactate, Arginine, Aspartic Acid, Pca, Glycine, Alanine, Serine, Valine, Proline, Threonine, Isoleucine, Histidine, Phenylalanine, Medicago Sativa (Alfalfa) Extract, Humulus Lupulus (Hops) Extract, Rosmarinus Officinalis (Rosemary) Extract, Melilotus Officinalis Extract. /// 2%

(Rosemary) Extract, Helianthus Annuus Extract /// 0.2%

Propylene Glycol, Aqua, Rosmarinus Officinalis (Rosemary) Leaf Extract, Chamomilla Recutita (Matricaria) Flower Extract, Arnica Montana Flower Extract, Lamium Album Extract, Salvia Officinalis (Sage) Leaf Extract, Pinus Sylvestris Bud Extract, Nasturtium Officinale Extract, Actium Majus Root Extract, Citrus Medica Limonum (Lemon) Peel Extract, Hedera Helix (Ivy) Leaf Extract, Calendula Officinalis Flower Extract, Tropaeolum Majus Flower Extract /// 0.20%

Uses

Anti hair loss treatment

Warnings

Ask a doctor if:

For external use.

May cause eye irritation. Discontinue use if irritation or rash occurs.

If pregnant or breast-feeding, ask a health professional before use.

Keep out of reach of children.

Directions

Apply as needed

Other Information

Store at room temperature

Inactive Ingredients

Listed in front label.

Questions or comments?

800-313-0903

customerservice@tmbrandsusa.com

use.

professional before

Drug Facts

Active Ingredients

Butylene Glycol (and) Aqua (and) PPG-26-Buteth-26 (and) PEG-40 Hydrogenated Castor Oil (and) Apigenin (and) Oleoic Acid (and)

000001111peptide-1 // 1%

Water (Aqua), Glycerin, Alcohol, Sodium PCA, Sodium Lactate, Arginine, Aspartic Acid, Pca, Glycine, Alanine, Serine, Valine, Proline, Threonine, Isoleucine, Histidine, Phenylalanine, Medicago Sativa (Alfalfa) Extract, Humulus Lupulus (Hops) Extract, Rosmarinus Officinalis (Rosemary) Extract, Helibolus Officinalis Extract. /// 2%

Propylene Glycol, Aqua, Rosmarinus Officinalis (Rosemary) Leaf Extract, Chamomilla Recutita (Matricaria) Flower Extract, Arnica Montana Flower Extract, Lamium Album Extract, Salvia Officinalis (Sage) Leaf Extract, Pinus Sylvestris Bud Extract, Nasturtium Officinale Extract, Actium Majus Root Extract, Citrus Medica Limonum (Lemon) Peel Extract, Hedera Helix (Ivy) Leaf Extract, Calendula Officinalis Flower Extract, Tropaeolum Majus Flower Extract. /// 0.20%

Uses

Anti hair loss treatment

Warnings

Ask a doctor if:

For external use.

May cause eye irritation. Discontinue use if irritation or rash occurs.

If pregnant or breast-feeding, ask a health professional before use.

Keep out of reach of children.

Directions

Apply as needed

Other Information

Store at room temperature

Inactive Ingredients

Listed in front label.

Questions or comments?

800-313-0903

customerservice@tmbrandsusa.com

Purpose

800-313-0903

customerservice@tmbrandsusa.com

Drug Facts

Active Ingredients

Butylene Glycol (and) Aqua (and) PPG-26-Buteth-26 (and) PEG-40 Hydrogenated Castor Oil (and) Apigenin (and) Oleoic Acid (and) BioGlycyl Tripeptide-1 /// 3%

Water (Aqua), Glycerin, Alcohol, Sodium PCA, Sodium Lactate, Arginine, Aspartic Acid, Pca, Glycine, Alanine, Serine, Valine, Proline, Threonine, Isoleucine, Histidine, Phenylalanine, Medicago Sativa (Alfalfa) Extract, Humulus Lupulus (Hops) Extract, Rosmarinus Officinalis (Rosemary) Extract, Helibcus Officinalis Extract. /// 2%

Propylene Glycol, Aqua, Rosmarinus Officinalis (Rosemary) Leaf Extract, Chamomilla Recutita (Matricaria) Flower Extract, Arnica Montana Flower Extract, Lamium Album Extract, Salvia Officinalis (Sage) Leaf Extract, Pinus Sylvestris Bud Extract, Nasturtium Officinale Extract, Actium Majus Root Extract, Citrus Medica Limonum (Lemon) Peel Extract, Hedera Helix (Ivy) Leaf Extract, Calendula Officinalis Flower Extract, Tropaeolum Majus Flower Extract. /// 0.20%

Uses

Anti hair loss treatment

Warnings

Ask a doctor if:

For external use.

May cause eye irritation. Discontinue use if irritation or rash occurs.

If pregnant or breast-feeding, ask a health professional before use.

Keep out of reach of children.

Directions

Apply as needed

Other Information

Store at room temperature

Inactive Ingredients

Listed in front label.

Questions or comments?

800-313-0903

customerservice@tmbrandsusa.com

Drug Facts

Active Ingredients

Butylene Glycol (and) Aqua (and) PPG-26-Buteth-26 (and) PEG-90 Hydrogenated Castor Oil (and) Apigenin (and) Oleic Acid (and) Biotinoyl Tripeptide-1 /// 3%

Water (Aqua), Glycerin, Alcohol, Sodium PCA, Sodium Lactate, Arginine, Aspartic Acid, Pca, Glycine, Alanine, Serine, Valine, Proline, Threonine, Isoleucine, Histidine, Phenylalanine, Medicago Sativa (Alfalfa) Extract, Humulus Lupulus (Hops) Extract, Rosmarinus Officinalis (Rosemary) Extract, Helibulus Officinalis Extract. /// 2%

Propylene Glycol, Aqua, Rosmarinus Officinalis (Rosemary) Leaf Extract, Chamomilla Recutita (Matricaria) Flower Extract, Anisa Montana Flower Extract, Lamium Album Extract, Salvia Officinalis (Sage) Leaf Extract, Pinus Sylvestris Bud Extract, Nasturtium Officinale Extract, Actium Hajas Root Extract, Citrus Medica Limonum (Lemon) Peel Extract, Hedera Helix (Ivy) Leaf Extract, Calendula Officinalis Flower Extract, Tropaeolum Hajas Flower Extract. /// 0.20%

Uses

Anti hair loss treatment

Warnings

Ask a doctor if:

For external use.

May cause eye irritation. Discontinue use if irritation or rash occurs.

If pregnant or breast-feeding, ask a health professional before use.

Keep out of reach of children.

Directions

Apply as needed

Other Information

Store at room temperature

Inactive Ingredients

Listed in front label.

Questions or comments?

800-313-0903

customerservice@tmbrandsusa.com

Stop use if

Drug Facts

Active Ingredients

Butylene Glycol (and) Aqua (and) PPG-26-Buteth-26 (and) PEG-40 Hydrogenated Castor Oil (and) Apigenin (and) Oleic Acid (and) Biotinoyl Tripeptide-1 /// 3%

Water (Aqua), Glycerin, Alcohol, Sodium PCA, Sodium Lactate, Arginine, Aspartic Acid, Pca, Glycine, Alanine, Serine, Valine, Proline, Threonine, Isoleucine, Histidine, Phenylalanine, Medicago Sativa (Milk) Extract, Humulus Lupulus (Hops) Extract, Rosmarinus Officinalis (Rosemary) Extract, Helibolus Officinalis Extract. /// 2%

Propylene Glycol, Aqua, Rosmarinus Officinalis (Rosemary) Leaf Extract, Chamomilla Recutita (Matricaria) Flower Extract, Arnica Montana Flower Extract, Lamium Album Extract, Salvia Officinalis (Sage) Leaf Extract, Pinus Sylvestris Bud Extract, Nasturtium Officinale Extract, Actium Majus Root Extract, Citrus Medica Limonum (Lemon) Peel Extract, Hedera Helix (Ivy) Leaf Extract, Calendula Officinalis Flower Extract, Tropaeolum Majus Flower Extract. /// 0.20%

Uses

Anti hair loss treatment

Warnings

Ask a doctor if:

For external use.

May cause eye irritation. Discontinue use if irritation or rash occurs.

If pregnant or breast-feeding, ask a health professional before use.

Keep out of reach of children.

Directions

Apply as needed

Other Information

Store at room temperature

Inactive Ingredients

Listed in front label.

Questions or comments?

800-313-0903

customerservice@trnbrandsusa.com

When using

Drug Facts

Drug Facts

Active Ingredients

Butylene Glycol (and) Aqua (and) PPG-26-Buteth-26 (and) PEG-40 Hydrogenated Castor Oil (and) Apigenin (and) Oleoic Acid (and) Botinoyl Tripeptide-1 /// 3%

Water (Aqua), Glycerin, Alcohol, Sodium PCA, Sodium Lactate, Arginine, Aspartic Acid, Pca, Glycine, Alanine, Serine, Valine, Proline, Threonine, Isoleucine, Histidine, Phenylalanine, Medicago Sativa (Alfalfa) Extract, Humulus Lupulus (Hops) Extract, Rosmarinus Officinalis (Rosemary) Extract, Heliotropium Officinale Extract. /// 2%

Propylene Glycol, Aqua, Rosmarinus Officinalis (Rosemary) Leaf Extract, Chamomilla Recutita (Matricaria) Flower Extract, Arnica Montana Flower Extract, Lamium Album Extract, Salvia Officinalis (Sage) Leaf Extract, Pinus Sylvestris Bud Extract, Nasturtium Officinale Extract, Actium Majus Root Extract, Citrus Medica Limonum (Lemon) Peel Extract, Hedera Helix (Ivy) Leaf Extract, Calendula Officinalis Flower Extract, Tropaeolum Majus Flower Extract. /// 0.20%

Uses

Anti hair loss treatment

Warnings

Ask a doctor if:

For external use.

May cause eye irritation. Discontinue use if irritation or rash occurs.

If pregnant or breast-feeding, ask a health professional before use.

Keep out of reach of children.

Directions

Apply as needed

Other Information

Store at room temperature

Inactive Ingredients

Listed in front label.

Questions or comments?

800-313-0903

customerservice@tmbrandsusa.com

Inactive

Drug Facts

Active Ingredients

Butylene Glycol (and) Aqua (and) PPG-26-Buteth-26 (and) PEG-40 Hydrogenated Castor Oil (and) Apigenin (and) Oleonic Acid (and) Bioinoyl Tripeptide-1 /// 3%

Water (Aqua), Glycerin, Alcohol, Sodium PCA, Sodium Lactate, Arginine, Aspartic Acid, Pca, Glycine, Alanine, Serine, Valine, Proline, Threonine, Isoleucine, Histidine, Phenylalanine, Medicago Sativa (Alfalfa) Extract, Humulus Lupulus (Hops) Extract, Rosmarinus Officinalis (Rosemary) Extract, Helibius Officinalis Extract. /// 2%

Propylene Glycol, Aqua, Rosmarinus Officinalis (Rosemary) Leaf Extract, Chamomilla Recutita (Matricaria) Flower Extract, Arnica Montana Flower Extract, Lamium Album Extract, Salvia Officinalis (Sage) Leaf Extract, Pinus Sylvestris Bud Extract, Nasturtium Officinale Extract, Actium Majus Root Extract, Citrus Medica Limonum (Lemon) Peel Extract, Hedera Helix (Ivy) Leaf Extract, Calendula Officinalis Flower Extract, Tropaeolum Majus Flower Extract. /// 0.20%

Uses

Anti hair loss treatment

Warnings

Ask a doctor if:

For external use.

May cause eye irritation. Discontinue use if irritation or rash occurs.

If pregnant or breast-feeding, ask a health professional before use.

Keep out of reach of children.

Directions

Apply as needed

Other Information

Store at room temperature

Inactive Ingredients

Listed in front label.

Questions or comments?

800-313-0903

customerservice@tmbrandsusa.com

PMS
872 C

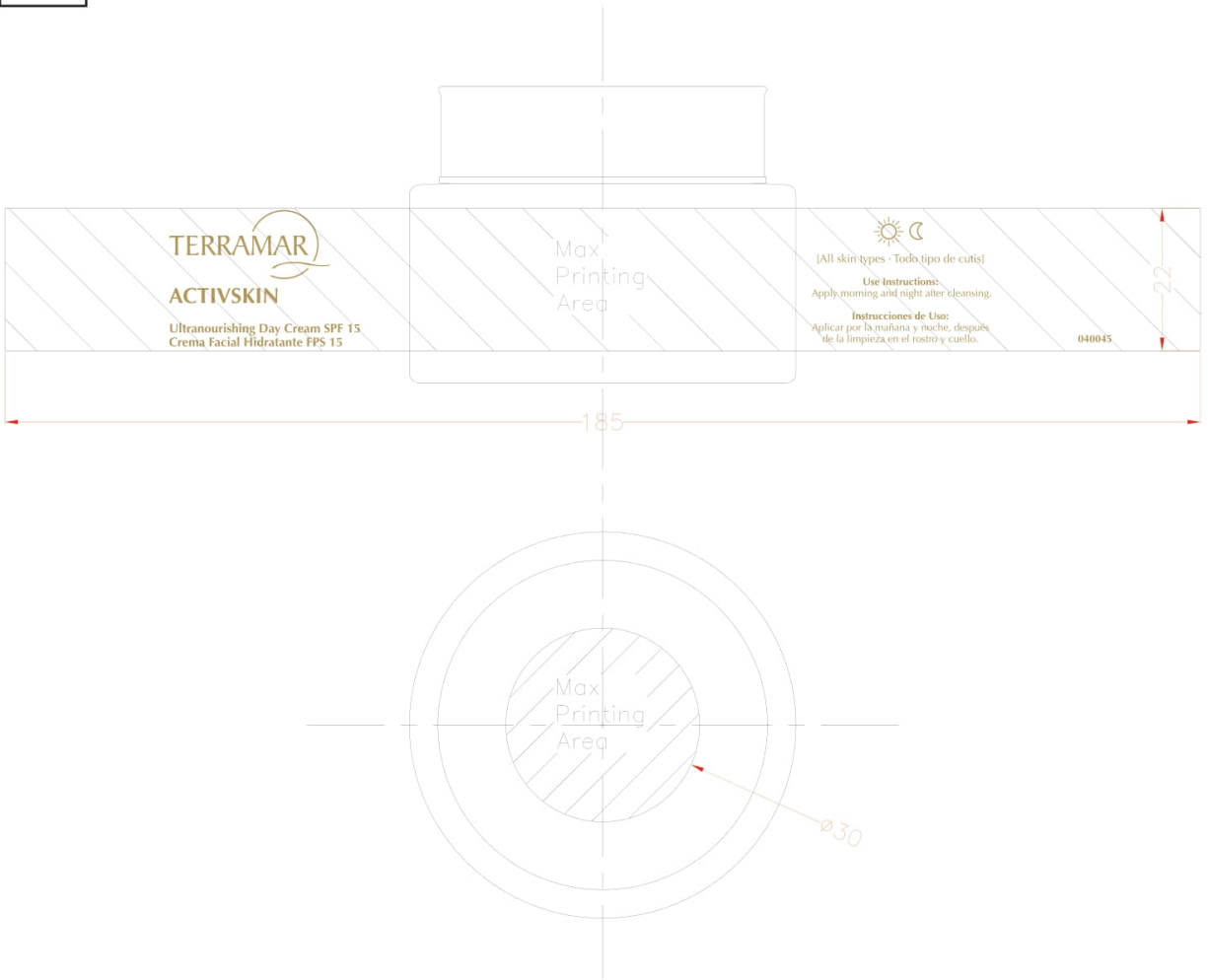

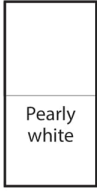

4.1338

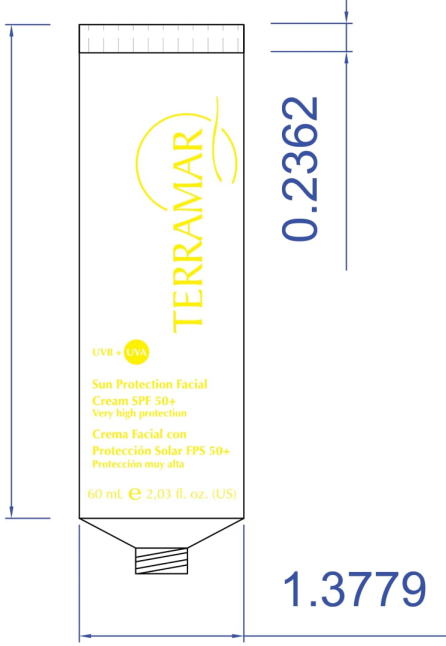

0.9330



1.3779

4.3287

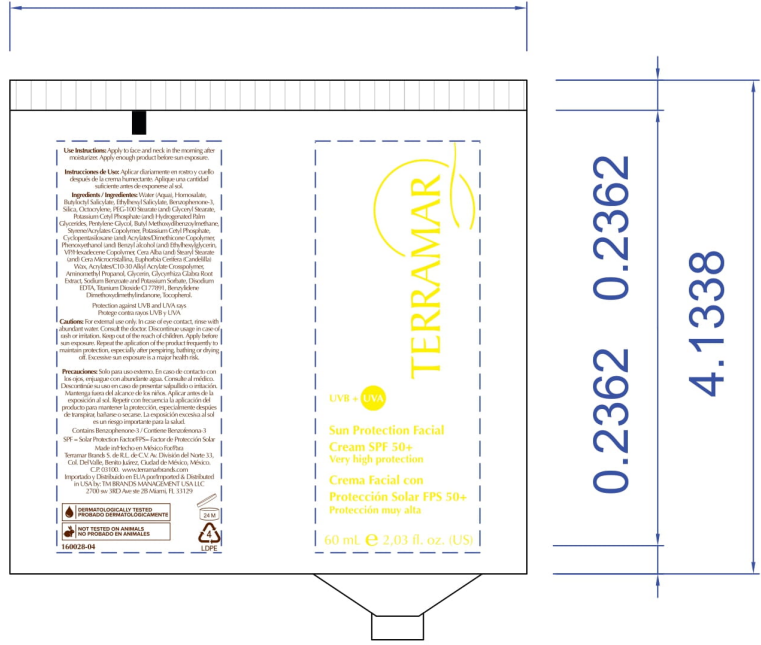

Use Instructions: Apply to face and neck in the morning after showering. Apply through product before sun exposure.
Instrucciones de Uso: Aplicar diariamente en mañanas y tardes después de la ducha o afeitado. Aplicar una cantidad suficiente antes de exponerse al sol.
Ingredientes / Ingredientes: Water / Agua, Homosalate, Butyl Methoxydibenzoylmethane / Butilmetoxidibenzilmetano, Silica, Octocrylene, PEG-10 Stearate (and Glyceryl Stearate), Titanium Dioxide (and Iron Oxides) (TiO₂ / Fe₂O₃), Cyclopentasiloxane, Ethylhexyl Methoxycinnamate, Dimethylaminoethyl Tetrahydro Pteridine, Phenoxyethanol (and Benzyl Alcohol) (and Ethylhexylglycerin), Ultraviolet A / Ultravioleta A, Glycerin, Ethylhexyl Salicylate, and Creole Marine Oil / Aceite de Mar Caribe y plantas de Mar, Acetyl Glucoside, Glycerin, Chlorophyllin Copper Salt, Sodium Hexametaphosphate, Dimethylaminoethyl Tetrahydro Pteridine, Glycerin, Chlorophyllin Copper Salt, Ethylhexyl Salicylate, and Titanium Dioxide, Diethylaminoethyl Tetrahydro Pteridine, Acetyl Glucoside.
 Protection against UVA and UVB rays.
 Protección contra rayos UVA y UVB.
Caution: For external use only. In case of eye contact, rinse with abundant water. Consult the doctor. Do not use on severely irritated or sunburned skin. Avoid contact with the eyes. Do not use on children. Apply before sun exposure. Repeat the application after prolonged exposure to maintain protection, especially after perspiring, bathing, or wiping off. Excessive sun exposure is a major health risk.
Precauciones: Solo para uso externo. En caso de contacto con los ojos, enjuague con abundante agua. Consulte al médico. Evite el uso en caso de presentar sensibilidad o irritación. No utilizar en niños. Aplicar antes de la exposición al sol. Repetir con frecuencia la aplicación del producto para mantener la protección, especialmente después de transpirar, bañarse o secarse. La exposición excesiva al sol es un riesgo importante para la salud.
 Contenido: 60 mL (2.03 fl. oz.) Factor de Protección Solar SPF - Solar Protection Factor (SPF) - Factor de Protección Solar.
 Made in the USA by The BRANDS MANUFACTURING COMPANY
 Brand: TERRAMAR
 Item #: 169028-01
 NOT RECYCLED ON ANIMAL FEEDING PREMISES
 169028-01
 LRPB

TERRAMAR
 UVA + UVB
 Sun Protection Facial
 Cream SPF 50+
 Very high protection
 Crema Facial con
 Protección Solar FPS 50+
 Protección muy alta
 60 mL e 2.03 fl. oz. (US)

MATERIAL:
CARTULINA
SULFATADA
18 PUNTOS

IMPRESIÓN:
OFFSET

TINTAS:
2X0



LOGO
TERRAMAR

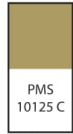

TEXTOS USO
E INGREDIENTES

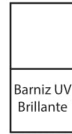

PLASTA A REGISTRO
INDICADA EN CAPA

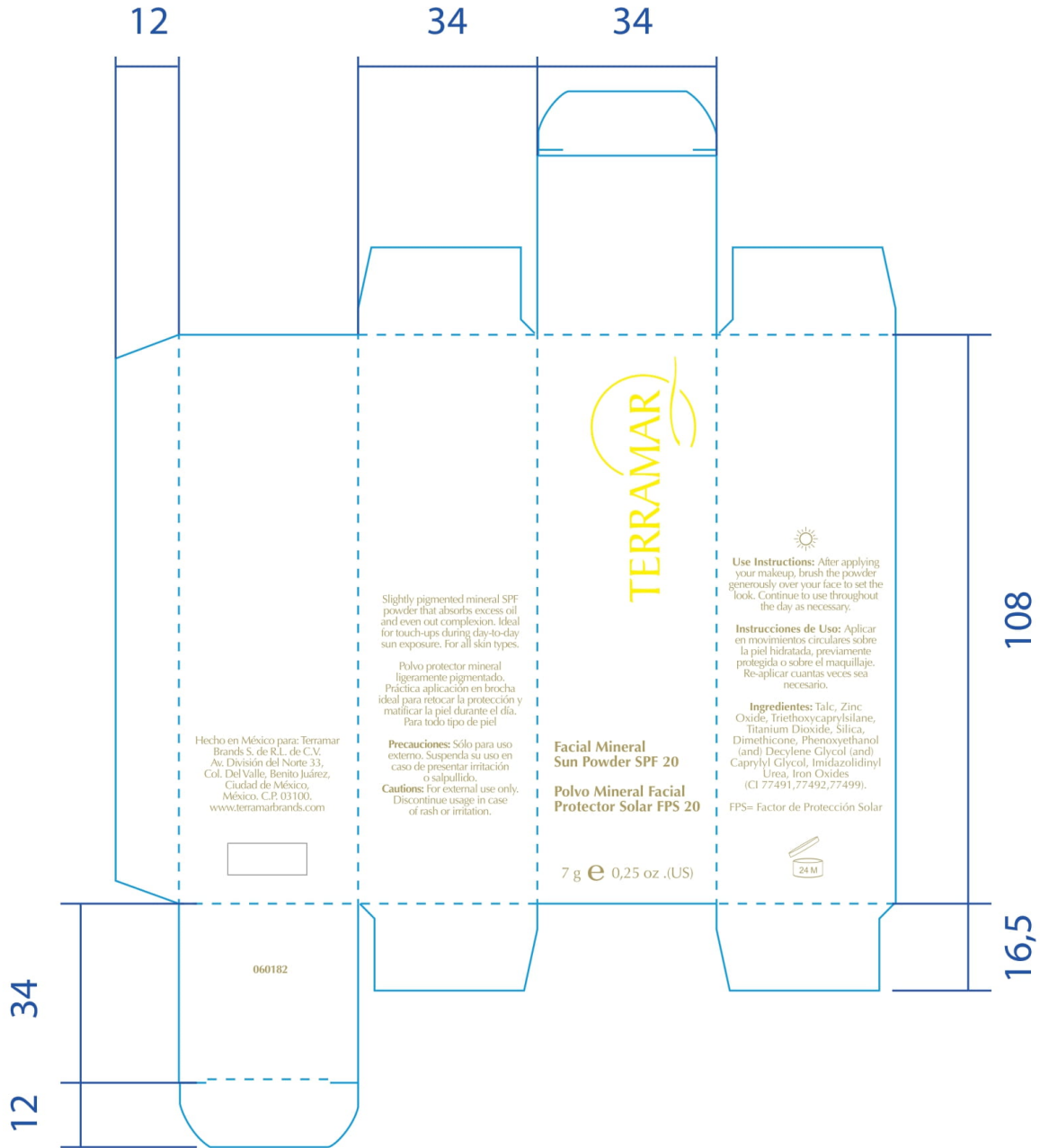

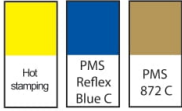

Decoration: Matte gold

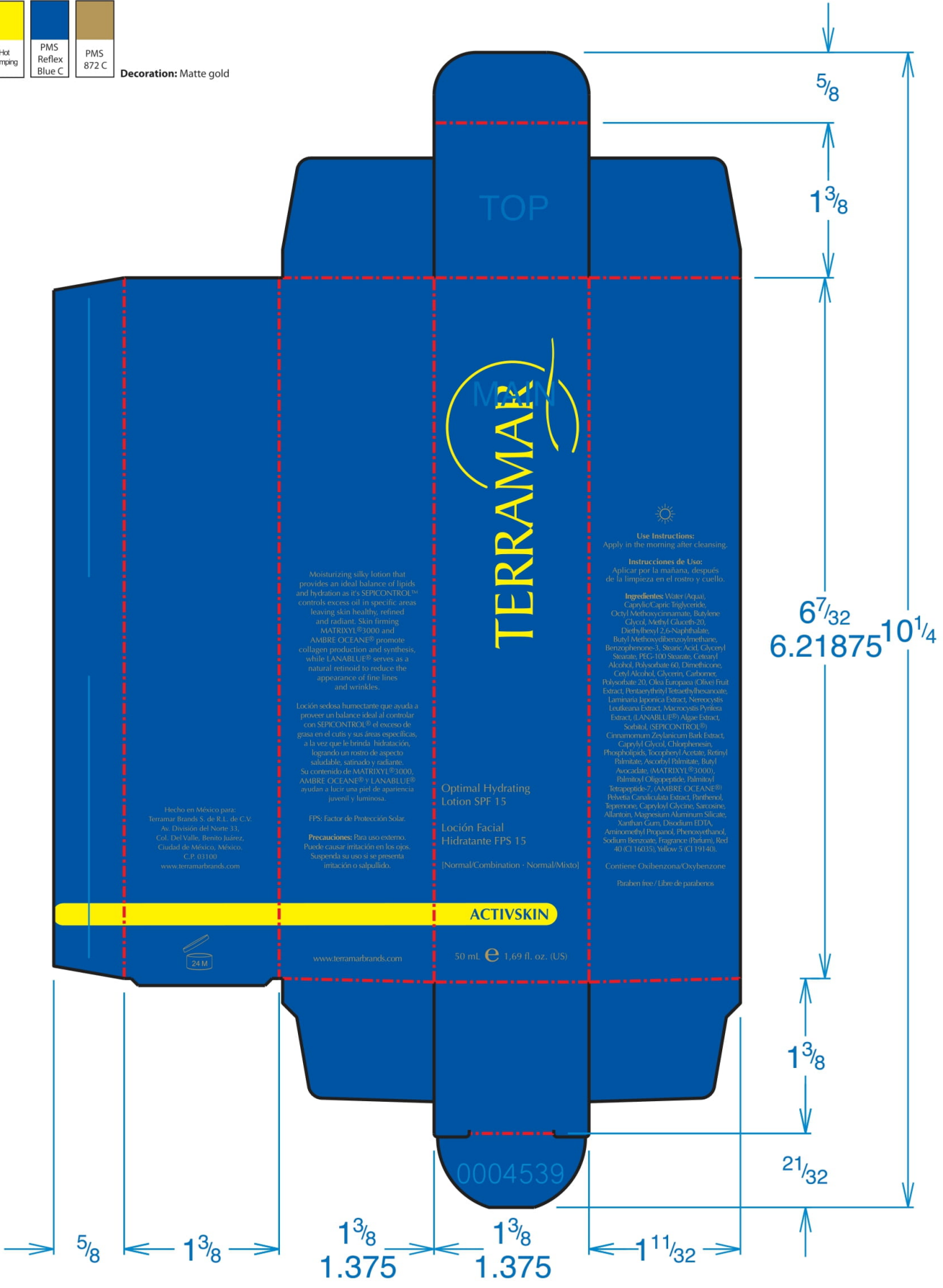

Moisturizing silky lotion that provides an ideal balance of lipids and hydration as its SEPICONTROL® controls excess oil in specific areas leaving skin healthy, refined and radiant. Skin firming MATRIXYL®3000 and AMBRE OCEANE® promote collagen production and synthesis, while LANABLU® serves as a natural retinoid to reduce the appearance of fine lines and wrinkles.

Loción sedosa humectante que ayuda a proveer un balance ideal al controlar con SEPICONTROL® el exceso de grasa en el cutis y sus áreas específicas, a la vez que le brinda hidratación, logrando un rostro de aspecto saludable, satinado y radiante. Su contenido de MATRIXYL®3000, AMBRE OCEANE® y LANABLU® ayudan a hacer una piel de apariencia juvenil y luminosa.

FPS: Factor de Protección Solar.

Precauciones: Para uso externo. Puede causar irritación en los ojos. Suspénda su uso si se presenta irritación o salpicado.

Hecho en México para:
Terramar Brands S. de R.L. de C.V.
Av. División del Norte 33,
Col. Del Valle, Benito Juárez,
Ciudad de México, México.
C.P. 03100
www.terramarbrands.com

www.terramarbrands.com

Optimal Hydrating
Lotion SPF 15

Loción Facial
Hidratante FPS 15

[Normal/Combination - Normal/Mixto]

ACTIVSKIN

50 mL e 1.69 fl. oz. (US)

 **Use Instructions:**
Apply in the morning after cleansing.

Instrucciones de Uso:
Aplicar por la mañana, después de la limpieza en el rostro y cuello.

Ingredientes: Water (Aqua), Caprylic/Capric Triglyceride, Octyl Methoxycinnamate, Butylene Glycol, Methyl Glucoside-20, Diethylhexyl 2,6-Naphthalate, Butyl Methoxydibenzoylmethane, Benzophenone-3, Stearic Acid, Glycerol Stearate, PEG-100 Stearate, Cetearyl Alcohol, Polyisobutyl Acrylate, Cetyl Alcohol, Glyceryl Caprylate, Polyisobutyl 20, Olea Europaea (Olive) Fruit Extract, Pentaerythrityl Tetraethylhexanoate, Laminaria Japonica Extract, Nereocystis Lutescens Extract, Microcystis Pyrioides Extract, LANABLU®, Algae Extract, Sorbitol, SEPICONTROL®, Cinnamomum Zeylanicum Bark Extract, Caprylyl Glycol, Chlorphenesin, Phospholipids, Tocopheryl Acetate, Retinyl Palmitate, Acetyl Palmitate, Butyl Acrylate, MATRIXYL®3000, Palmitoyl Oligopeptide, Palmitoyl Tetrapeptide-7, AMBRE OCEANE®, Polvetia Canaliculata Extract, Panthenol, Tapenone, Capryloyl Glycine, Sarcosine, Allantoin, Magnesium Aluminum Silicate, Xanthan Gum, Disodium EDTA, Aminomethyl Propanol, Phenoxethanol, Sodium Benzoate, Fragrance (Parfum), Red 40 (CI 16035), Yellow 5 (CI 19140).

Contiene Oxibenzona/Oxybenzone
Paraben free/ Libre de parabenos

$6\frac{7}{32}$
6.21875 $10\frac{1}{4}$

$1\frac{3}{8}$

$2\frac{1}{32}$

$1\frac{3}{8}$
1.375

$1\frac{3}{8}$
1.375

$1\frac{11}{32}$

$\frac{5}{8}$

$1\frac{3}{8}$

$\frac{5}{8}$

$1\frac{3}{8}$

TOP

MATTE
TERRAMAR

0004539





Decoration: Matte gold hot stamping



Note: All dimensions are in millimeters

CONFIDENTIAL

This document contains proprietary information of Arminak & Associates. Its receipt or possession does not convey any rights to reproduce or disclose its contents or to manufacture, use, or sell anything it may describe. Reproduction, disclosure, or use without specific written authorization of Arminak & Associates, Inc. is strictly forbidden.

AIRLESS BOTTLE					
Rev.	Date	Description			
		Capacity: 50ml			
		Output: 0.2cc			
				Sheet	1 of 1
Date	07/14/08	Scale	1:1	Dwg No.	AAJ2450ML12

Arminak & Associates

1350 Mountain View Circle

Azusa, CA 91702

Tel. (626)358-4804 Fax (626)358-4688

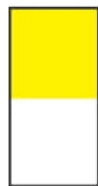

Decorado:
Hot stamping
oro brillante



Decorado:
Serigrafía



Envase



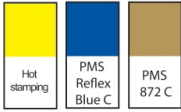

Decoration: Matte gold

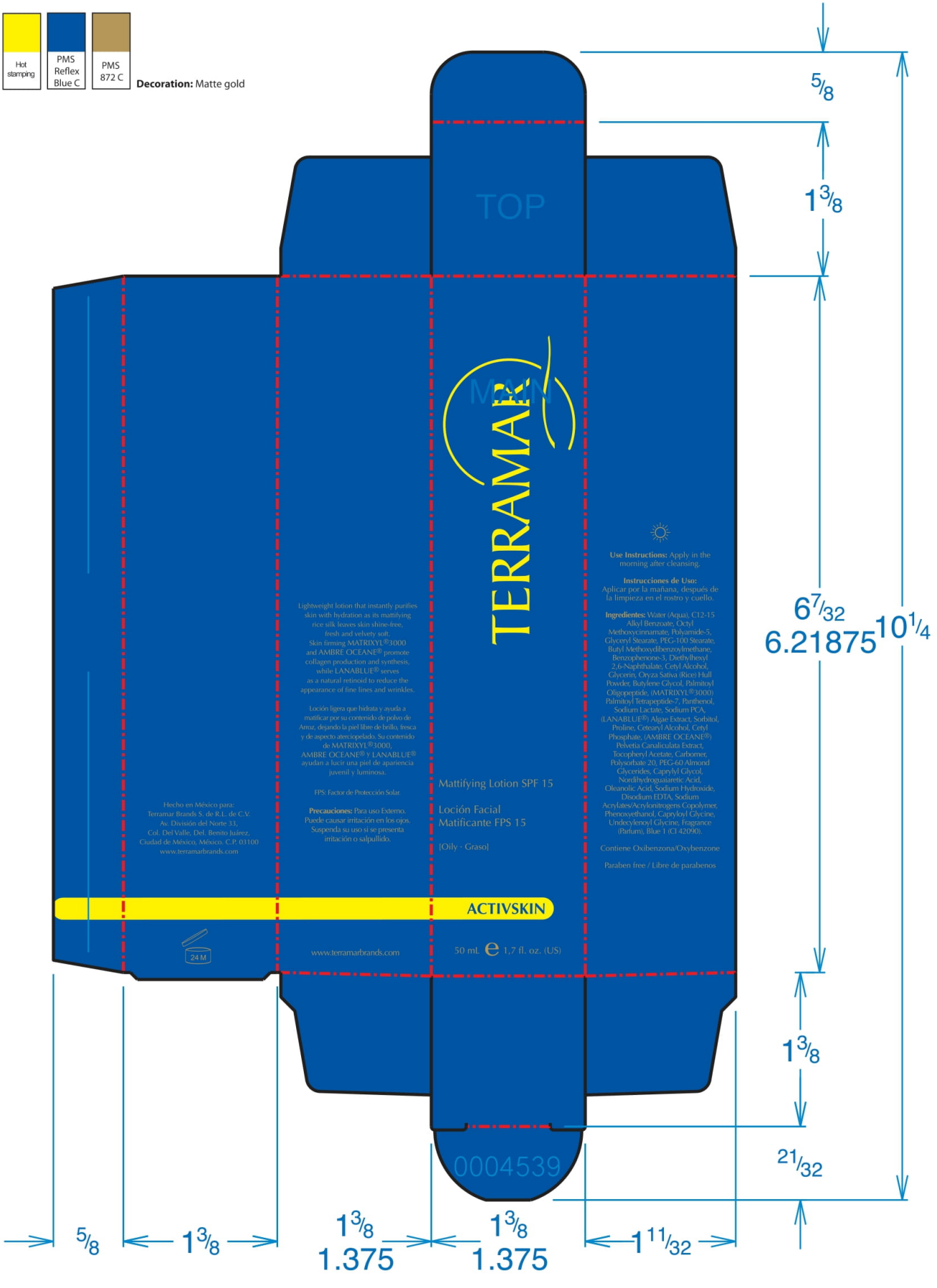

6⁷/₃₂
6.21875 10¹/₄

Hecho en México para:
Terramar Brands S. de R.L. de C.V.
Av. División del Norte 33,
Col. Del Valle, Del. Benito Juárez,
Ciudad de México, México, C.P. 03100
www.terramarbrands.com

Lightweight lotion that instantly purifies skin with hydration as its mattifying rice silk, leaves skin thin, free, fresh and velvety soft. Skin-firming MATRIXYL®3000 and AMBRE OCEANE® promote collagen production and synthesis, while LANABLU® serives as a natural retinoid to reduce the appearance of fine lines and wrinkles.

Loción ligera que hidrata y ayuda a matificar por su contenido de polvo de Arroz, dejando la piel lisa de fondo, fresca y de aspecto atecopado. Su contenido de MATRIXYL®3000, AMBRE OCEANE® y LANABLU® ayudan a lucir una piel de apariencia juvenil y luminosa.

FPS: Factor de Protección Solar

Precauciones: Para uso Externo. Puede causar irritación en los ojos. Suspénda su uso si se presenta irritación o salpullido.

Mattifying Lotion SPF 15

Loción Facial Matificante FPS 15

(Oilly - Graso)

ACTIVSKIN

www.terramarbrands.com

50 mL e 1.7 fl. oz. (US)

Use Instructions: Apply in the morning after cleansing.

Instrucciones de Uso: Aplicar por la mañana, después de la limpieza en el rostro y cuello.

Ingredientes: Water (Aqua), CI2-15, Allyl Benzoinate, Octyl Methoxycinnamate, Polyamide-5, Glyceryl Stearate, PEG-100 Stearate, Butyl Methoxydibenzoylmethane, Benzophenone-3, Diethylhexyl 2,6-Naphthalate, Cetyl Alcohol, Glycerin, Oryza Sativa (Rice) Hull Powder, Butylene Glycol, Palmitoyl Oligopeptide, (MATRIXYL®3000) Palmitoyl Tetrapeptide-7, Panthenol, Sodium Lactate, Sodium PCA, (LANABLU®) Algae Extract, Sorbitol, Pinine, Glycerol, Alcohol, Cetyl Phosphate, (AMBRE OCEANE®) Polyvetta Canaliculata Extract, Tocopheryl Acetate, Carbomer, Polybutene-20, (PEG-40) Almond Glyceryl, Caprylyl Glycol, Nordihydroguaiaretic Acid, Oleoic Acid, Sodium Hydroxide, Disodium EDTA, Sodium Acrylate/Acrylonitrile Copolymer, Phenoxethanol, Capryloyl Glycine, Undecylenoyl Glycine, Fragrance (Parfum), Blue 1 (CI 42090).

Contiene Oxibenzona/Oxybenzone Paraben free / Libre de parabenos

0004539

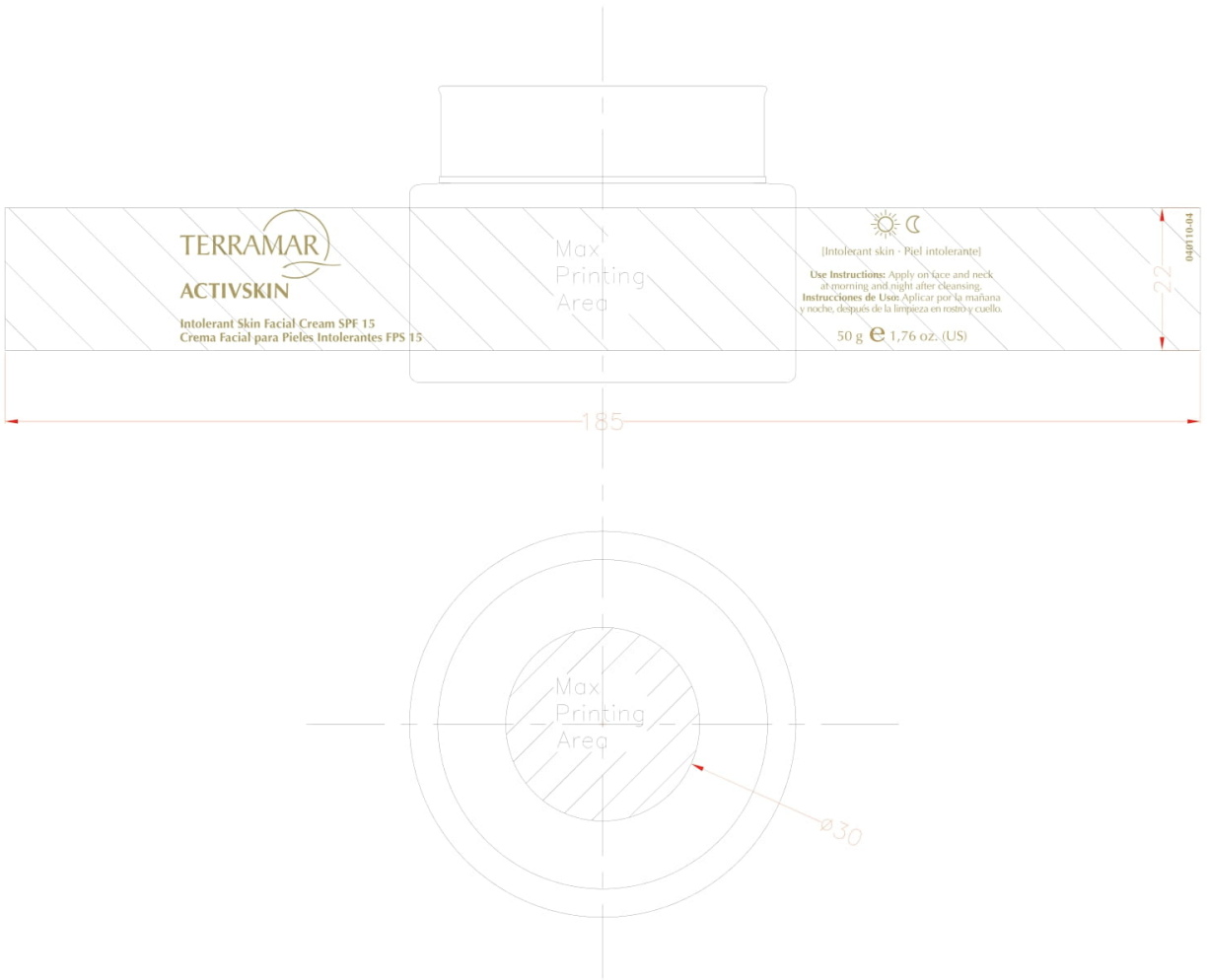
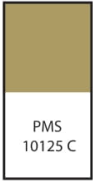



Hot Stamping
oro
brillante

PANEL
FRENTE



PMS
872 C

PANEL
VUELTA



Blanco
perlado

ENVASE



Decoration:

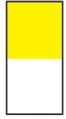

Hot stamping
oro brillante

Tubo:



PMS
Reflex
Blue C

LLEVA BARNIZ EXCEPTO
EN AREAS DE SELLO

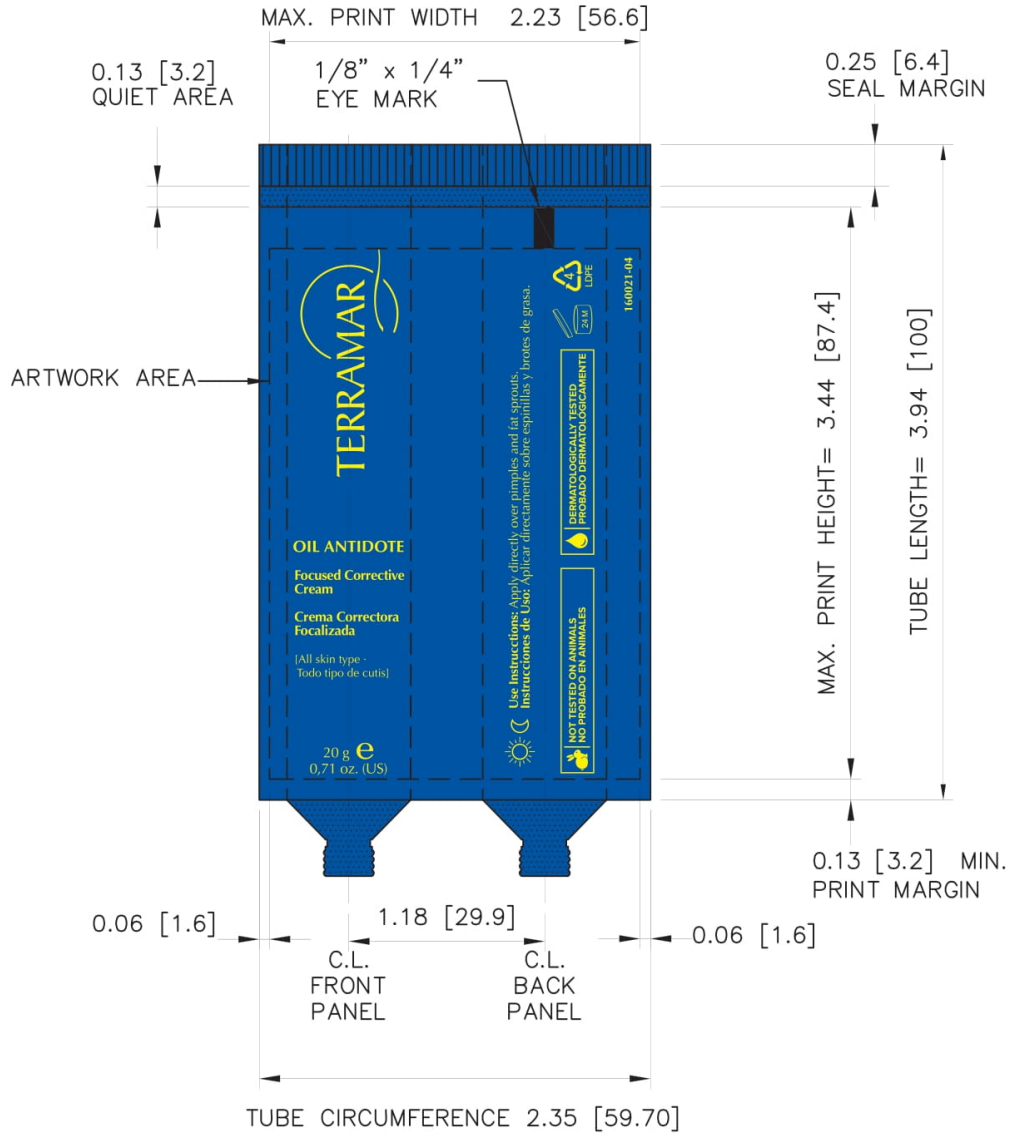



Decoration: Matte gold hot stamping



Note: All dimensions are in millimeters

CONFIDENTIAL

This document contains proprietary information of Arminak & Associates. Its receipt or possession does not convey any rights to reproduce or disclose its contents or to manufacture, use, or sell anything it may describe. Reproduction, disclosure, or use without specific written authorization of Arminak & Associates, Inc. is strictly forbidden.

AIRLESS BOTTLE					
Rev.	Date	Description			
		Capacity: 50ml			
		Output: 0.2cc			
				Sheet	1 of 1
Date	07/14/08	Scale	1:1	Dwg No.	AAJ2450ML12

Arminak & Associates

1350 Mountain View Circle

Azusa, CA 91702

Tel. (626)358-4804 Fax (626)358-4688

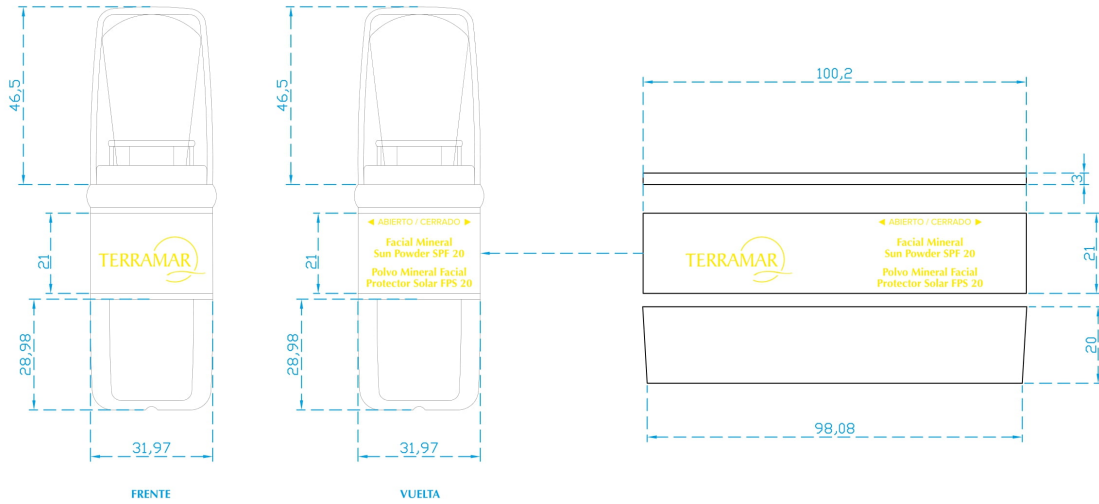

Hot stamping
oro brillante

CUSTOMER				DATE	2007.09.28
PRODUCT	ML-070928 DECO AREA			DESIGN	M.
MAT'L	—	UNIT	MM	REVIEW	—
PROCESS	—	SCALE	—	CHECK	J. CHANG
PROJECTION		ANGLE	—	APPROVE	HSU. J
 MARKET LINK <small>SMART VISION GROUP</small>				DWG NO.	—

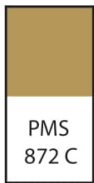

PMS
872 C

Decoration:
Matte gold
hot stamping

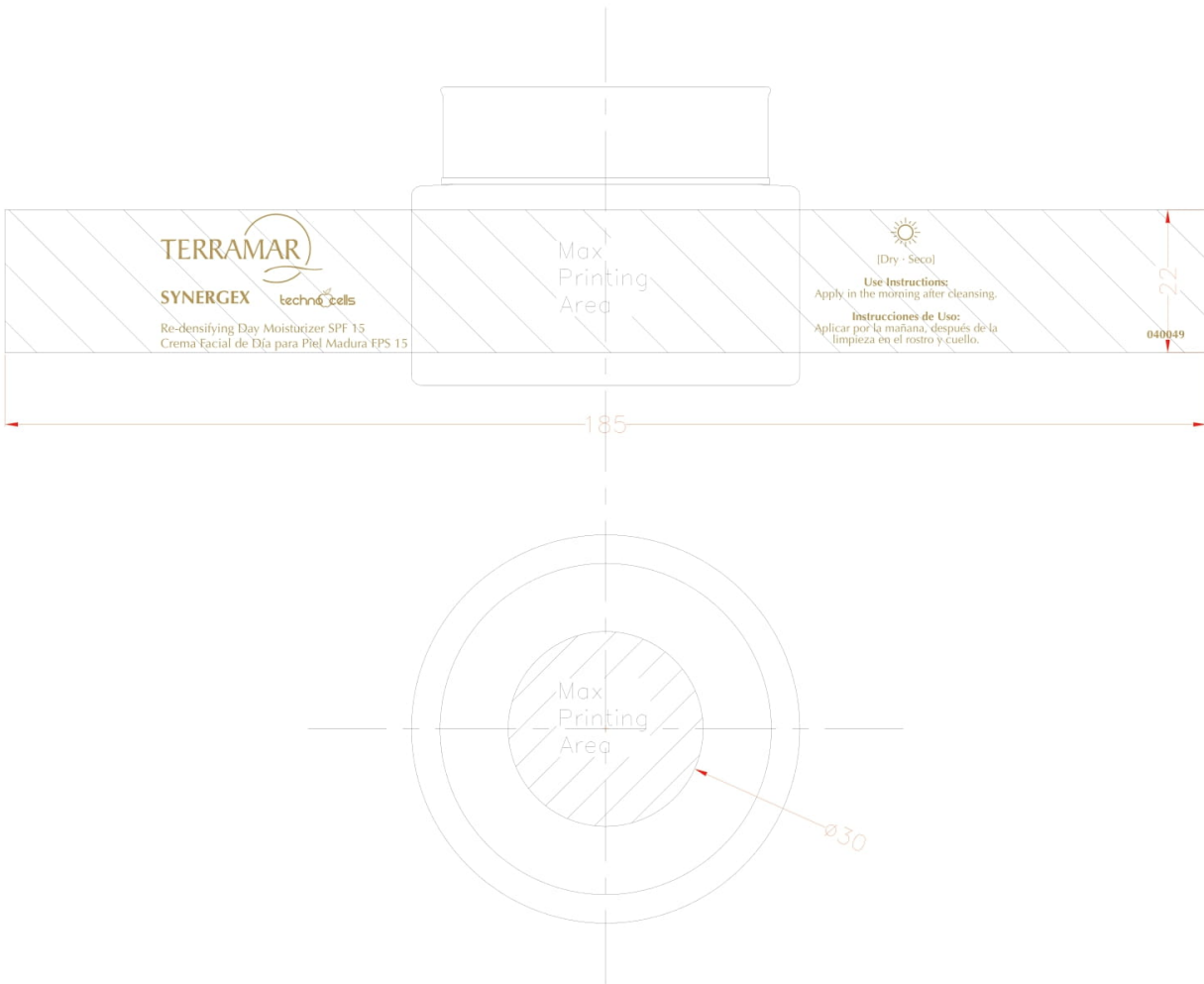

MATERIAL:
CARTULINA
SULFATADA
18 PUNTOS

IMPRESIÓN:
OFFSET
TINTAS:
ZVI



LOGO
TERRAMAR
PLECA



FONDO
AZUL



TEXTOS USO
E INGREDIENTES



PLASTA A REGISTRO
INDICADA EN CAPA

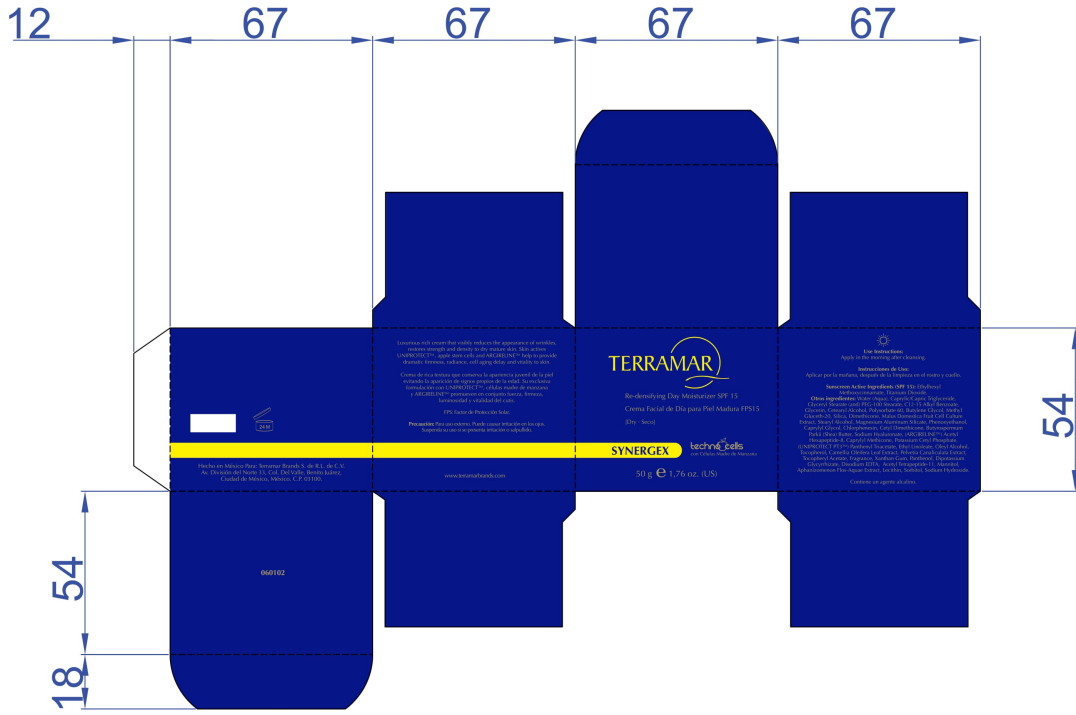

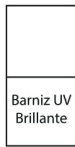
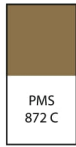
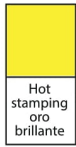

PLASTA A REGISTRO
INDICADA EN CAPA

Dimensión extendida:
15.9 x 19.8 cm
Realizó: Gramz

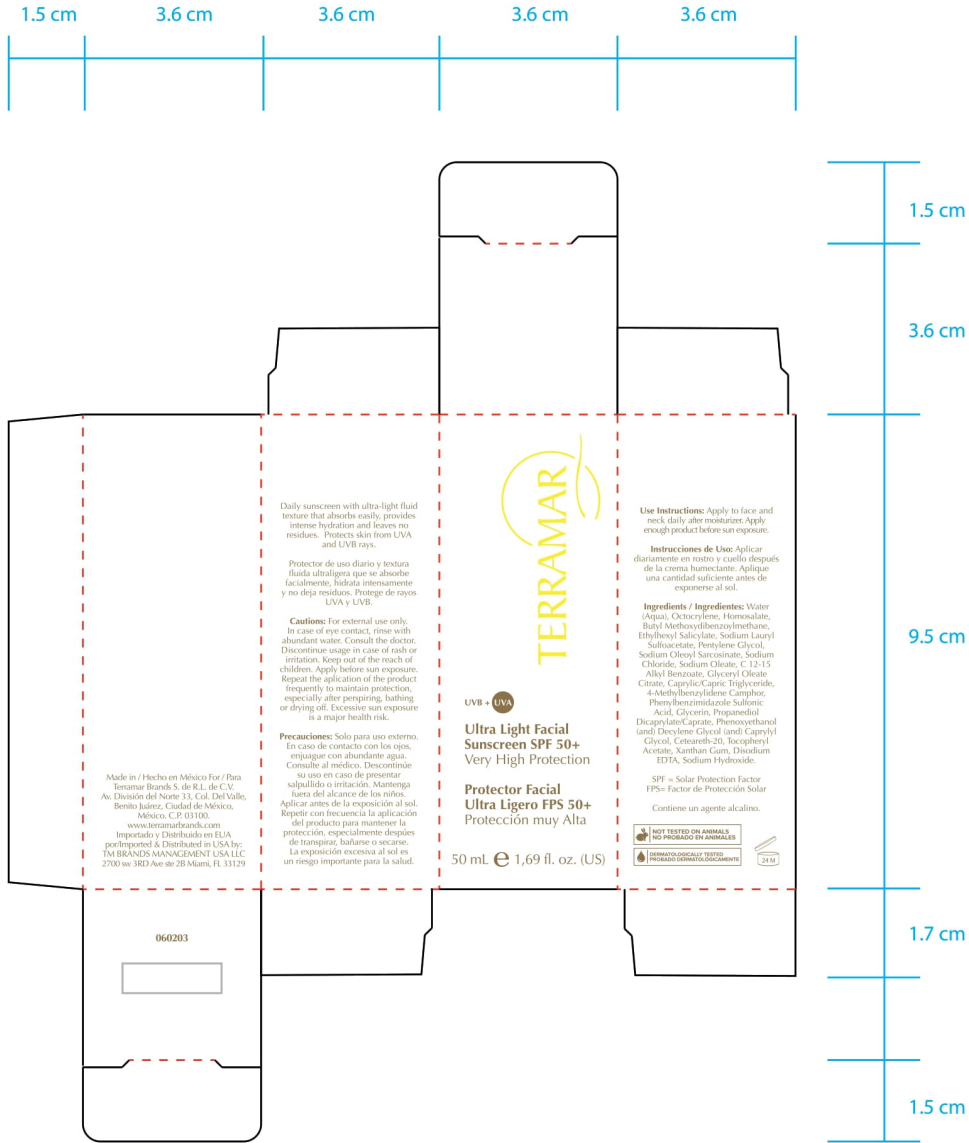

Selección de color

Etiqueta transparente

Cama de blanco (está indicada en una capa del archivo)

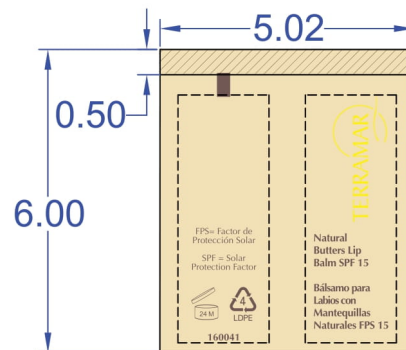
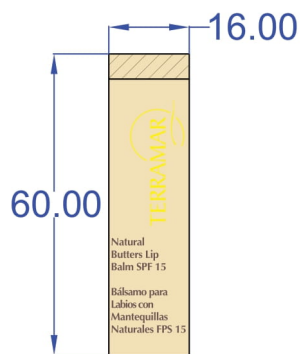
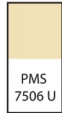
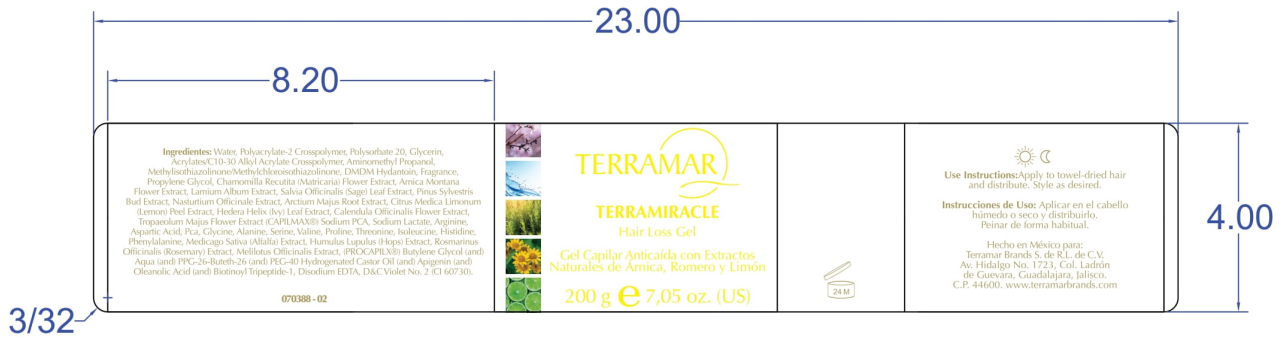
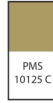

MATERIAL:
CARTULINA
SULFATADA
18 PUNTOS

IMPRESIÓN:
OFFSET
TINTAS:
2X0



PLASTA A REGISTRO
INDICADA EN CAPA

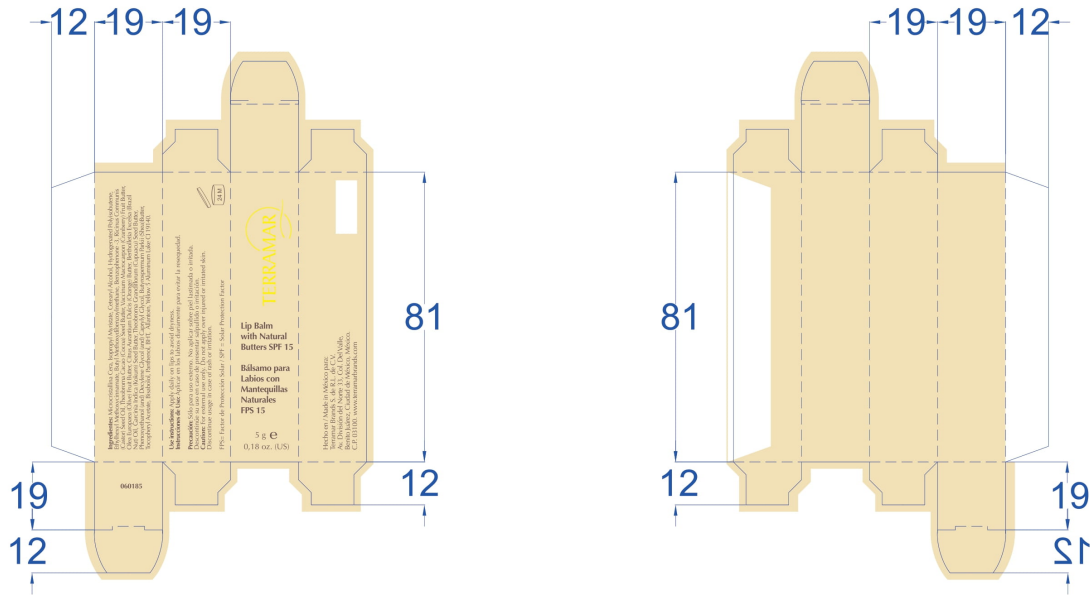

HYDRATING FACIAL CREAM SPF 15 DRY SKIN

ethylhexyl methoxycinnamate, butyl methoxydibenzoylmethane, benzophenone3 cream

Product Information

Product Type	HUMAN OTC DRUG	Item Code (Source)	NDC:82736-008
Route of Administration	TOPICAL		

Active Ingredient/Active Moiety

Ingredient Name	Basis of Strength	Strength
OCTINOXATE (UNII: 4Y5P7MUD51) (OCTINOXATE - UNII:4Y5P7MUD51)	OCTINOXATE	0.1 g in 1 g

Inactive Ingredients

Ingredient Name	Strength
HYDRATED SILICA (UNII: Y607T4G8P9)	0.7 g in 1 g
DIMETHICONE (UNII: 92RU3N3Y1O)	0.1 g in 1 g
TITANIUM DIOXIDE (UNII: 15FIX9V2JP)	0.1 g in 1 g

Packaging

#	Item Code	Package Description	Marketing Start Date	Marketing End Date
---	-----------	---------------------	----------------------	--------------------

1	NDC:82736-008-01	1 g in 1 CARTON; Type 0: Not a Combination Product	05/26/2022	
---	------------------	--	------------	--

Marketing Information

Marketing Category	Application Number or Monograph Citation	Marketing Start Date	Marketing End Date
OTC monograph final	part352	05/26/2022	

BALM WITH NATURAL BUTTERS SPF15

octinoxate lipstick

Product Information

Product Type	HUMAN OTC DRUG	Item Code (Source)	NDC:82736-010
Route of Administration	TOPICAL		

Active Ingredient/Active Moiety

Ingredient Name	Basis of Strength	Strength
OCTINOXATE (UNII: 4Y5P7MUD51) (OCTINOXATE - UNII:4Y5P7MUD51)	OCTINOXATE	0.1 g in 1 g

Inactive Ingredients

Ingredient Name	Strength
AVOBENZONE (UNII: G63QQF2NOX)	0.8 g in 1 g
BENZOPHENONE-2 (UNII: PRR8K3H9VN)	0.1 g in 1 g

Packaging

#	Item Code	Package Description	Marketing Start Date	Marketing End Date
1	NDC:82736-010-01	1 g in 1 CARTON; Type 0: Not a Combination Product	05/26/2022	

Marketing Information

Marketing Category	Application Number or Monograph Citation	Marketing Start Date	Marketing End Date
OTC monograph not final	part352	05/26/2022	

EYELASH AND EYEBROW LENGTHENER

propylene glycol cream

Product Information

Product Type	HUMAN OTC DRUG	Item Code (Source)	NDC:82736-019
Route of Administration	TOPICAL		

Active Ingredient/Active Moiety

Ingredient Name	Basis of Strength	Strength
PROPYLENE GLYCOL (UNII: 6DC9Q167V3) (PROPYLENE GLYCOL - UNII:6DC9Q167V3)	PROPYLENE GLYCOL	0.1 g in 1 g

Inactive Ingredients

Ingredient Name	Strength
MYRISTOYL PENTAPEPTIDE-4 (UNII: PMA59A699X)	0.1 g in 1 g
WATER (UNII: 059QF0KO0R)	0.7 g in 1 g
GLYCERIN (UNII: PDC6A3C0OX)	0.1 g in 1 g

Packaging

#	Item Code	Package Description	Marketing Start Date	Marketing End Date
1	NDC:82736-019-02	1 g in 1 CARTON; Type 0: Not a Combination Product	05/26/2022	

Marketing Information

Marketing Category	Application Number or Monograph Citation	Marketing Start Date	Marketing End Date
OTC monograph not final	part349	05/26/2022	

FACIAL PRIMER PROTECTOR SPF 50

homosalate cream

Product Information

Product Type	HUMAN OTC DRUG	Item Code (Source)	NDC:82736-020
Route of Administration	TOPICAL		

Active Ingredient/Active Moiety

Ingredient Name	Basis of Strength	Strength
HOMOSALATE (UNII: V06SV4M95S) (HOMOSALATE - UNII:V06SV4M95S)	HOMOSALATE	0.1 g in 1 g

Inactive Ingredients

Ingredient Name	Strength
BENZOPHENONE-2 (UNII: PRR8K3H9VN)	0.7 g in 1 g
BUTYL OXOACETATE (UNII: AH46A7531R)	0.1 g in 1 g
OCTOCRYLENE (UNII: 5A68WGF6WM)	0.1 g in 1 g

Packaging

#	Item Code	Package Description	Marketing Start Date	Marketing End Date
1	NDC:82736-020-01	1 g in 1 CARTON; Type 0: Not a Combination Product	05/26/2022	

Marketing Information

Marketing Category	Application Number or Monograph Citation	Marketing Start Date	Marketing End Date
OTC monograph not final	part352	05/26/2022	

HYDRATING FACIAL SPF 15 MIX NORMAL SKIN

octinoxate cream

Product Information

Product Type	HUMAN OTC DRUG	Item Code (Source)	NDC:82736-012
Route of Administration	TOPICAL		

Active Ingredient/Active Moiety

Ingredient Name	Basis of Strength	Strength
OCTINOXATE (UNII: 4Y5P7MUD51) (OCTINOXATE - UNII:4Y5P7MUD51)	OCTINOXATE	0.1 g in 1 g

Inactive Ingredients

Ingredient Name	Strength
OXYBENZONE (UNII: 950OS7VE0Y)	0.8 g in 1 g
AVOBENZONE (UNII: G63QQF2NOX)	0.1 g in 1 g

Packaging

#	Item Code	Package Description	Marketing Start Date	Marketing End Date
1	NDC:82736-012-01	1 g in 1 CARTON; Type 0: Not a Combination Product	05/26/2022	

Marketing Information

Marketing Category	Application Number or Monograph Citation	Marketing Start Date	Marketing End Date
OTC monograph not final	part352	05/26/2022	

ULTRA LIGHT FACIAL SUNSCREEN SPF 50

octocrylene cream

Product Information

Product Type	HUMAN OTC DRUG	Item Code (Source)	NDC:82736-015
Route of Administration	TOPICAL		

Active Ingredient/Active Moiety

Ingredient Name	Basis of Strength	Strength
OCTOCRYLENE (UNII: 5A68WGF6VM) (OCTOCRYLENE - UNII:5A68WGF6VM)	OCTOCRYLENE	0.1 g in 1 g
AVOBENZONE (UNII: G63QQF2NOX) (AVOBENZONE - UNII:G63QQF2NOX)	AVOBENZONE	0.8 g in 1 g

Inactive Ingredients

Ingredient Name	Strength
OXYBENZONE (UNII: 95OOS7VE0Y)	0.1 g in 1 g

Packaging

#	Item Code	Package Description	Marketing Start Date	Marketing End Date
1	NDC:82736-015-01	1 g in 1 CARTON; Type 0: Not a Combination Product	05/26/2022	

Marketing Information

Marketing Category	Application Number or Monograph Citation	Marketing Start Date	Marketing End Date
OTC monograph not final	part352	05/26/2022	

ANTI LOSS TREATMENT TERRAMAR

3-hexyloxypropylene glycol cream

Product Information

Product Type	HUMAN OTC DRUG	Item Code (Source)	NDC:82736-018
Route of Administration	TOPICAL		

Active Ingredient/Active Moiety

Ingredient Name	Basis of Strength	Strength
3-HEXYLOXYPROPYLENE GLYCOL (UNII: 3485P35DA4) (3-HEXYLOXYPROPYLENE GLYCOL - UNII:3485P35DA4)	3-HEXYLOXYPROPYLENE GLYCOL	0.1 g in 1 g
SALICYLIC ACID (UNII: O414PZ4LPZ) (SALICYLIC ACID - UNII:O414PZ4LPZ)	SALICYLIC ACID	0.1 g in 1 g

Inactive Ingredients

Ingredient Name	Strength
ARNICA CORDIFOLIA FLOWER (UNII: JCG1OSZ7A8)	0.1 g in 1 g
SALVIA APIANA LEAF (UNII: Z29Z21AHMP)	0.7 g in 1 g

Packaging

#	Item Code	Package Description	Marketing Start Date	Marketing End Date
1	NDC:82736-018-01	1 g in 1 CARTON; Type 0: Not a Combination Product	05/26/2022	

Marketing Information

Marketing Category	Application Number or Monograph Citation	Marketing Start Date	Marketing End Date
OTC monograph final	M032	05/26/2022	

ANTILOSS TERRAMAR SH

propylene glycol 1 - oleate cream

Product Information

Product Type	HUMAN OTC DRUG	Item Code (Source)	NDC:82736-017
Route of Administration	TOPICAL		

Active Ingredient/Active Moiety

Ingredient Name	Basis of Strength	Strength
PROPYLENE GLYCOL 1-OLEATE (UNII: 476821E6GS) (PROPYLENE GLYCOL 1-OLEATE - UNII:476821E6GS)	PROPYLENE GLYCOL 1-OLEATE	0.1 g in 1 g
SALICYLIC ACID (UNII: O414PZ4LPZ) (SALICYLIC ACID - UNII:O414PZ4LPZ)	SALICYLIC ACID	0.1 g in 1 g

Inactive Ingredients

Ingredient Name	Strength
ARNICA CHAMISSONIS FLOWER (UNII: 88WK5I8R3L)	0.7 g in 1 g
SALVIA APIANA LEAF (UNII: Z29Z21AHMP)	0.1 g in 1 g

Packaging

#	Item Code	Package Description	Marketing Start Date	Marketing End Date
1	NDC:82736-017-01	1 g in 1 CARTON; Type 0: Not a Combination Product	05/26/2022	

Marketing Information

Marketing Category	Application Number or Monograph Citation	Marketing Start Date	Marketing End Date
OTC monograph final	M032	05/26/2022	

SKIN RECOVERY FACE SPF 15

octinoxate cream

Product Information

Product Type	HUMAN OTC DRUG	Item Code (Source)	NDC:82736-011
Route of Administration	TOPICAL		

Active Ingredient/Active Moiety

Ingredient Name	Basis of Strength	Strength
OCTINOXATE (UNII: 4Y5P7MUD51) (OCTINOXATE - UNII:4Y5P7MUD51)	OCTINOXATE	0.1 g in 1 g

Inactive Ingredients

Ingredient Name	Strength
TITANIUM DIOXIDE (UNII: 15FIX9V2JP)	0.7 g in 1 g
DIMETHICONE CROSSPOLYMER (450000 MPA.S AT 12% IN CYCLOPENTASILOXANE) (UNII: UF7620L1W6)	0.1 g in 1 g
SILICON (UNII: Z4152N8IU)	0.1 g in 1 g

Packaging

#	Item Code	Package Description	Marketing Start Date	Marketing End Date
1	NDC:82736-011-01	1 g in 1 CARTON; Type 0: Not a Combination Product	05/26/2022	

Marketing Information

Marketing Category	Application Number or Monograph Citation	Marketing Start Date	Marketing End Date
--------------------	--	----------------------	--------------------

OTC monograph not final	part352	05/26/2022	
-------------------------	---------	------------	--

MATTIFYING FACIAL SPF 15 OILY SKIN

octinoxate cream

Product Information

Product Type	HUMAN OTC DRUG	Item Code (Source)	NDC:82736-013
Route of Administration	TOPICAL		

Active Ingredient/Active Moiety

Ingredient Name	Basis of Strength	Strength
OCTINOXATE (UNII: 4Y5P7MUD51) (OCTINOXATE - UNII:4Y5P7MUD51)	OCTINOXATE	0.1 g in 1 g

Inactive Ingredients

Ingredient Name	Strength
OXYBENZONE (UNII: 95OOS7VE0Y)	0.1 g in 1 g
AVOBENZONE (UNII: G63QQF2NOX)	0.8 g in 1 g

Packaging

#	Item Code	Package Description	Marketing Start Date	Marketing End Date
1	NDC:82736-013-01	1 g in 1 CARTON; Type 0: Not a Combination Product	05/26/2022	

Marketing Information

Marketing Category	Application Number or Monograph Citation	Marketing Start Date	Marketing End Date
OTC monograph not final	part352	05/26/2022	

BODY SUNSCREEN FPS 50

octocrylene, homosalate, butyl methoxydibenzoylmethane, ethylhexyl salicylate, 4-methylbenzylidene camphor cream

Product Information

Product Type	HUMAN OTC DRUG	Item Code (Source)	NDC:82736-014
Route of Administration	TOPICAL		

Active Ingredient/Active Moiety				
	Ingredient Name		Basis of Strength	Strength
	OCTOCRYLENE (UNII: 5A68WGF6WM) (OCTOCRYLENE - UNII:5A68WGF6WM)		OCTOCRYLENE	0.1 g in 1 g
	AVOBENZONE (UNII: G63QQF2NOX) (AVOBENZONE - UNII:G63QQF2NOX)		AVOBENZONE	0.6 g in 1 g
Inactive Ingredients				
	Ingredient Name		Strength	
	HOMOSALATE (UNII: V06SV4M95S)		0.1 g in 1 g	
	ENZACAMENE (UNII: 8I3XWY40L9)		0.1 g in 1 g	
	OCTINOXATE (UNII: 4Y5P7MUD51)		0.1 g in 1 g	
Packaging				
#	Item Code	Package Description	Marketing Start Date	Marketing End Date
1	NDC:82736-014-01	1 g in 1 CARTON; Type 0: Not a Combination Product	05/26/2022	
Marketing Information				
Marketing Category	Application Number or Monograph Citation	Marketing Start Date	Marketing End Date	
OTC monograph not final	part352	05/26/2022		

PROTECTIVE MAKEUP SPF 15 WITH EDELWESS STEM CELLS				
ethylhexyl methoxycinnamate, benzophenone-3 cream				
Product Information				
Product Type	HUMAN OTC DRUG	Item Code (Source)	NDC:82736-004	
Route of Administration	TOPICAL			
Active Ingredient/Active Moiety				
	Ingredient Name		Basis of Strength	Strength
	OCTINOXATE (UNII: 4Y5P7MUD51) (OCTINOXATE - UNII:4Y5P7MUD51)		OCTINOXATE	0.1 g in 1 g
Inactive Ingredients				
	Ingredient Name		Strength	
	OXYBENZONE (UNII: 95OOS7VE0Y)		0.4 g in 1 g	
Packaging				
#	Item Code	Package Description	Marketing Start Date	Marketing End Date

#	Item Code	Package Description	Marketing Start Date	Marketing End Date
1	NDC:82736-004-01	1 g in 1 CARTON; Type 0: Not a Combination Product	05/26/2022	

Marketing Information			
Marketing Category	Application Number or Monograph Citation	Marketing Start Date	Marketing End Date
OTC monograph not final	part352	05/26/2022	

MAQUILLAJE LIQUIDO MAXIMA COBERTURA				
ethylhexyl methoxycinnamate, benzophenone- 3 cream				
Product Information				
Product Type	HUMAN OTC DRUG	Item Code (Source)	NDC:82736-006	
Route of Administration	TOPICAL			
Active Ingredient/Active Moiety				
Ingredient Name		Basis of Strength	Strength	
OCTINOXATE (UNII: 4Y5P7MUD51) (OCTINOXATE - UNII:4Y5P7MUD51)		OCTINOXATE	0.1 g in 1 g	
Inactive Ingredients				
Ingredient Name		Strength		
OXYBENZONE (UNII: 95OOS7VE0Y)		0.9 g in 1 g		
Packaging				
#	Item Code	Package Description	Marketing Start Date	Marketing End Date
1	NDC:82736-006-01	1 g in 1 CARTON; Type 0: Not a Combination Product	05/26/2022	
Marketing Information				
Marketing Category	Application Number or Monograph Citation	Marketing Start Date	Marketing End Date	
OTC monograph final	part352	05/26/2022		

MATURE SKIN FACIAL DAY SPF 15			
ethylhexyl methoxycinnamate, titanium dioxide, silica, dimethicone cream			

Product Information

Product Type	HUMAN OTC DRUG	Item Code (Source)	NDC:82736-005
Route of Administration	TOPICAL		

Active Ingredient/Active Moiety

Ingredient Name	Basis of Strength	Strength
OCTINOXATE (UNII: 4Y5P7MUD51) (OCTINOXATE - UNII:4Y5P7MUD51)	OCTINOXATE	0.1 g in 1 g
TITANIUM DIOXIDE (UNII: 15FIX9V2JP) (TITANIUM DIOXIDE - UNII:15FIX9V2JP)	TITANIUM DIOXIDE	0.1 g in 1 g

Inactive Ingredients

Ingredient Name	Strength
DIMETHICONE (UNII: 92RU3N3Y1O)	0.7 g in 1 g
SILICON (UNII: Z4152N8IU)	0.1 g in 1 g

Packaging

#	Item Code	Package Description	Marketing Start Date	Marketing End Date
1	NDC:82736-005-01	1 g in 1 CARTON; Type 0: Not a Combination Product	05/26/2022	

Marketing Information

Marketing Category	Application Number or Monograph Citation	Marketing Start Date	Marketing End Date
OTC monograph not final	part352	05/26/2022	

COLOR CORRECTING SPF 20

ethylhexyl methoxycinnamate, octocrylene, butyl methoxydibenzoylmethane cream

Product Information

Product Type	HUMAN OTC DRUG	Item Code (Source)	NDC:82736-002
Route of Administration	TOPICAL		

Active Ingredient/Active Moiety

Ingredient Name	Basis of Strength	Strength
OCTINOXATE (UNII: 4Y5P7MUD51) (OCTINOXATE - UNII:4Y5P7MUD51)	OCTINOXATE	0.1 g in 1 g

Inactive Ingredients

Ingredient Name	Strength
------------------------	-----------------

OCTOCRYLENE (UNII: 5A68WGF6VM)	0.8 g in 1 g
AVOBENZONE (UNII: G63QQF2NOX)	0.1 g in 1 g

Packaging

#	Item Code	Package Description	Marketing Start Date	Marketing End Date
1	NDC:82736-002-02	1 g in 1 CARTON; Type 0: Not a Combination Product	05/26/2022	

Marketing Information

Marketing Category	Application Number or Monograph Citation	Marketing Start Date	Marketing End Date
OTC monograph not final	part352	05/26/2022	

SUN PROTECTION FACIAL SPF 50

homosalate, neo heliopan, ethylhexyl salicylate, benzophenone-3, octocrylene, avoventzona (butyl methoxydibenzoylmethane), titanium dioxide ci 77891 cream

Product Information

Product Type	HUMAN OTC DRUG	Item Code (Source)	NDC:82736-009
Route of Administration	TOPICAL		

Active Ingredient/Active Moiety

Ingredient Name	Basis of Strength	Strength
HOMOSALATE (UNII: V06SV4M95S) (HOMOSALATE - UNII:V06SV4M95S)	HOMOSALATE	0.1 g in 1 g

Inactive Ingredients

Ingredient Name	Strength
OCTOCRYLENE (UNII: 5A68WGF6VM)	0.1 g in 1 g
OXYBENZONE (UNII: 95OOS7VE0Y)	0.5 g in 1 g
TITANIUM DIOXIDE (UNII: 15FIX9V2JP)	0.1 g in 1 g
OCTISALATE (UNII: 4X49Y0596W)	0.1 g in 1 g
AVOBENZONE (UNII: G63QQF2NOX)	0.1 g in 1 g

Packaging

#	Item Code	Package Description	Marketing Start Date	Marketing End Date
1	NDC:82736-009-01	1 g in 1 CARTON; Type 0: Not a Combination Product	05/26/2022	

Marketing Information

Marketing Category	Application Number or Monograph Citation	Marketing Start Date	Marketing End Date
OTC monograph not final	part352	05/26/2022	

ANTI HAIR LOSS GEL WITH ARNICA, ROSEMARY, AND LEMON EXTRACTS.

propylene glycol gel

Product Information

Product Type	HUMAN OTC DRUG	Item Code (Source)	NDC:82736-016
Route of Administration	TOPICAL		

Active Ingredient/Active Moiety

Ingredient Name	Basis of Strength	Strength
SALICYLIC ACID (UNII: O414PZ4LPZ) (SALICYLIC ACID - UNII:O414PZ4LPZ)	SALICYLIC ACID	0.1 g in 1 g

Inactive Ingredients

Ingredient Name	Strength
ROSMARINUS OFFICINALIS FLOWERING TOP (UNII: 8JM482TI79)	0.1 g in 1 g
CITRUS X LIMON FLOWERING TOP OIL (UNII: 4C38SS0J60)	0.7 g in 1 g
PROPYLENE GLYCOL (UNII: 6DC9Q167V3)	0.1 g in 1 g

Packaging

#	Item Code	Package Description	Marketing Start Date	Marketing End Date
1	NDC:82736-016-01	1 g in 1 CARTON; Type 0: Not a Combination Product	05/26/2022	

Marketing Information

Marketing Category	Application Number or Monograph Citation	Marketing Start Date	Marketing End Date
OTC monograph final	M032	05/26/2022	

DESODORANTE ANTIPERSPIRANT

aluminium chlorohydrate aerosol, spray

Product Information

Product Type	HUMAN OTC DRUG	Item Code (Source)	NDC:82736-003	
Route of Administration	INTRADERMAL, TOPICAL			
Active Ingredient/Active Moiety				
Ingredient Name		Basis of Strength	Strength	
ALUMINUM CHLOROHYDRATE (UNII: HPN8MZ W13M) (ALUMINUM CHLOROHYDRATE - UNII:HPN8MZ W13M)		ALUMINUM CHLOROHYDRATE	0.24 g in 1 g	
Inactive Ingredients				
Ingredient Name			Strength	
BISMUTH SUBCITRATE POTASSIUM (UNII: R3O80H60KX)			0.76 g in 1 g	
Packaging				
#	Item Code	Package Description	Marketing Start Date	Marketing End Date
1	NDC:82736-003-02	1 g in 1 CARTON; Type 0: Not a Combination Product	05/26/2022	
Marketing Information				
Marketing Category	Application Number or Monograph Citation	Marketing Start Date	Marketing End Date	
OTC monograph final	M019	05/26/2022		

FACIAL PRIMER PROTECTOR SPF 50

homosalate, benzophenone-3, octocrylene, ethylexyl salicylate, butyl methoxydibenzoylmethane cream

Product Information				
Product Type	HUMAN OTC DRUG	Item Code (Source)	NDC:82736-001	
Route of Administration	TOPICAL			
Active Ingredient/Active Moiety				
Ingredient Name		Basis of Strength	Strength	
OCTOCRYLENE (UNII: 5A68WGF6WM) (OCTOCRYLENE - UNII:5A68WGF6WM)		OCTOCRYLENE	0.1 g in 1 g	
OCTISALATE (UNII: 4X49Y0596W) (OCTISALATE - UNII:4X49Y0596W)		OCTISALATE	0.1 g in 1 g	
OXYBENZONE (UNII: 95OOS7VE0Y) (OXYBENZONE - UNII:95OOS7VE0Y)		OXYBENZONE	0.1 g in 1 g	
HOMOSALATE (UNII: V06SV4M95S) (HOMOSALATE - UNII:V06SV4M95S)		HOMOSALATE	0.1 g in 1 g	
Inactive Ingredients				

Ingredient Name	Strength
AVOBENZONE (UNII: G63QQF2NOX)	0.1 g in 1 g
ALUMINUM STARCH OCTENYLSUCCINATE (UNII: I9PJ006294)	0.3 g in 1 g
HYDROGENATED SOYBEAN LECITHIN (UNII: H1109Z9J4N)	0.1 g in 1 g
DIMETHICONE CROSSPOLYMER (450000 MPA.S AT 12% IN CYCLOPENTASILOXANE) (UNII: UF7620L1W6)	0.1 g in 1 g

Packaging

#	Item Code	Package Description	Marketing Start Date	Marketing End Date
1	NDC:82736-001-01	1 g in 1 CARTON; Type 0: Not a Combination Product	06/01/2022	

Marketing Information

Marketing Category	Application Number or Monograph Citation	Marketing Start Date	Marketing End Date
OTC monograph not final	part352	06/01/2022	

FOCUSED CORRECTIVE

water (aqua), butylene glycol, peg-60 almond glycerides, caprylyl glycol, glycerin, carbomer, nordihydroguaiaretic acid, oleanolic acid, beta vulgaris (beet) root extract, oenothera biennis (evening primrose) leaf extract cream

Product Information

Product Type	HUMAN OTC DRUG	Item Code (Source)	NDC:82736-007
Route of Administration	TOPICAL		

Active Ingredient/Active Moiety

Ingredient Name	Basis of Strength	Strength
AVOBENZONE (UNII: G63QQF2NOX) (AVOBENZONE - UNII:G63QQF2NOX)	AVOBENZONE	0.2 g in 1 g
BUTYLENE GLYCOL (UNII: 3XUS85K0RA) (BUTYLENE GLYCOL - UNII:3XUS85K0RA)	BUTYLENE GLYCOL	0.1 g in 1 g

Inactive Ingredients

Ingredient Name	Strength
WATER (UNII: 059QF0KO0R)	0.1 g in 1 g
CAPRYLYL GLYCOL (UNII: 00YIU5438U)	0.1 g in 1 g
OENOTHERA BIENNIS (UNII: 76UI55V071)	0.3 g in 1 g
PEG-60 ALMOND GLYCERIDES (UNII: 4Y0E651N0F)	0.1 g in 1 g
GLYCERIN (UNII: PDC6A3C0OX)	0.1 g in 1 g

Packaging

#	Item Code	Package Description	Marketing Start Date	Marketing End Date
1	NDC:82736-007-01	1 g in 1 CARTON; Type 0: Not a Combination Product	05/26/2022	

Marketing Information

Marketing Category	Application Number or Monograph Citation	Marketing Start Date	Marketing End Date
OTC monograph not final	part352	05/26/2022	

Labeler - TERRAMAR BRANDS S de RL de CV (588108527)

Registrant - TERRAMAR BRANDS S de RL de CV (588108527)

Establishment

Name	Address	ID/FEI	Business Operations
TERRAMAR BRAND S de RL de CV		588108527	manufacture(82736-008, 82736-010, 82736-019, 82736-020, 82736-012, 82736-015, 82736-018, 82736-017, 82736-011, 82736-013, 82736-014, 82736-004, 82736-006, 82736-005, 82736-002, 82736-009, 82736-016, 82736-003, 82736-001, 82736-007)

Revised: 5/2022

TERRAMAR BRANDS S de RL de CV