

# **EVEROLIMUS- everolimus tablet, for suspension**

## **Mylan Pharmaceuticals Inc.**

-----

### **HIGHLIGHTS OF PRESCRIBING INFORMATION**

**These highlights do not include all the information needed to use EVEROLIMUS TABLETS FOR ORAL SUSPENSION safely and effectively. See full prescribing information for EVEROLIMUS TABLETS FOR ORAL SUSPENSION.**

**EVEROLIMUS tablets for oral suspension**  
**Initial U.S. Approval: 2009**

### **RECENT MAJOR CHANGES**

Warnings and Precautions, Radiation Sensitization and Radiation Recall (5.12) 4/2021

### **INDICATIONS AND USAGE**

Everolimus tablets for oral suspension are a kinase inhibitor indicated for the treatment of adult and pediatric patients aged 1 year and older with TSC who have subependymal giant cell astrocytoma (SEGA) that requires therapeutic intervention but cannot be curatively resected. (1.5)

Everolimus tablets for oral suspension are a kinase inhibitor indicated for the adjunctive treatment of adult and pediatric patients aged 2 years and older with TSC-associated partial-onset seizures. (1.6)

### **DOSAGE AND ADMINISTRATION**

Do not combine AFINITOR® and everolimus tablets for oral suspension to achieve the total daily dose. (2.1)

Modify the dose for patients with hepatic impairment or for patients taking drugs that inhibit or induce P-glycoprotein (P-gp) and CYP3A4. (2.1)

TSC-Associated SEGA:

- 4.5 mg/m<sup>2</sup> orally once daily; adjust dose to attain trough concentrations of 5-15 ng/mL. (2.6, 2.8)

TSC-Associated Partial-Onset Seizures:

- 5 mg/m<sup>2</sup> orally once daily; adjust dose to attain trough concentrations of 5-15 ng/mL. (2.7, 2.8)

### **DOSAGE FORMS AND STRENGTHS**

Everolimus tablets for oral suspension: 2 mg, 3 mg, and 5 mg tablets (3)

### **CONTRAINDICATIONS**

Clinically significant hypersensitivity to everolimus or to other rapamycin derivatives. (4)

### **WARNINGS AND PRECAUTIONS**

- Non-Infectious Pneumonitis: Monitor for clinical symptoms or radiological changes. Withhold or permanently discontinue based on severity. (2.9, 5.1)
- Infections: Monitor for signs and symptoms of infection. Withhold or permanently discontinue based on severity. (2.9, 5.2)
- Severe Hypersensitivity Reactions: Permanently discontinue for clinically significant hypersensitivity. (5.3)
- Angioedema: Patients taking concomitant angiotensin-converting-enzyme (ACE) inhibitors may be at increased risk for angioedema. Permanently discontinue for angioedema. (5.4, 7.2)
- Stomatitis: Initiate dexamethasone alcohol-free mouthwash when starting treatment. (5.5)
- Renal Failure: Monitor renal function prior to treatment and periodically thereafter. (5.6)
- Risk of Impaired Wound Healing: Withhold for at least 1 week prior to elective surgery. Do not administer for at least 2 weeks following major surgery and until adequate wound healing. The safety of resumption of treatment after resolution of wound healing complications has not been established. (5.7)
- Metabolic Disorders: Monitor serum glucose and lipids prior to treatment and periodically thereafter. Withhold or permanently discontinue based on severity. (2.9, 5.9)
- Myelosuppression: Monitor hematologic parameters prior to treatment and periodically thereafter. Withhold or permanently discontinue based on severity. (2.9, 5.10)
- Risk of Infection or Reduced Immune Response with Vaccination: Avoid live vaccines and close contact with those who have received live vaccines. Complete recommended childhood vaccinations prior to starting treatment. (5.11)
- Radiation Sensitization and Radiation Recall: Severe radiation reactions may occur. (5.12, 6.2)

- Embryo-Fetal Toxicity: Can cause fetal harm. Advise patients of reproductive potential of the potential risk to a fetus and to use effective contraception. (5.13, 8.1, 8.3)

#### ADVERSE REACTIONS

TSC-Associated SEGA: Most common adverse reactions (incidence  $\geq$  30%) are stomatitis and respiratory tract infection. (6.1)

TSC-Associated Partial-Onset Seizures: Most common adverse reaction (incidence  $\geq$  30%) is stomatitis. (6.1)

**To report SUSPECTED ADVERSE REACTIONS, contact Mylan at 1-877-446-3679 (1-877-4-INFO-RX) or FDA at 1-800-FDA-1088 or [www.fda.gov/medwatch](http://www.fda.gov/medwatch).**

#### DRUG INTERACTIONS

- P-gp and strong CYP3A4 inhibitors: Avoid concomitant use. (2.11, 7.1)
- P-gp and moderate CYP3A4 inhibitors: Reduce the dose as recommended. (2.11, 7.1)
- P-gp and strong CYP3A4 inducers: Increase the dose as recommended. (2.12, 7.1)

#### USE IN SPECIFIC POPULATIONS

- For patients with TSC-associated SEGA or TSC-associated partial-onset seizures and severe hepatic impairment, reduce the starting dose and adjust dose to attain target trough concentrations. (2.8, 2.10, 8.6)

**See 17 for PATIENT COUNSELING INFORMATION and FDA-approved patient labeling.**

**Revised: 5/2023**

---

## FULL PRESCRIBING INFORMATION: CONTENTS\*

### 1 INDICATIONS AND USAGE

1.5 Tuberous Sclerosis Complex (TSC)-Associated Subependymal Giant Cell Astrocytoma (SEGA)

1.6 Tuberous Sclerosis Complex (TSC)-Associated Partial-Onset Seizures

### 2 DOSAGE AND ADMINISTRATION

2.1 Important Dosage Information

2.6 Recommended Dosage for Tuberous Sclerosis Complex (TSC)-Associated Subependymal Giant Cell Astrocytoma (SEGA)

2.7 Recommended Dosage for Tuberous Sclerosis Complex (TSC)-Associated Partial-Onset Seizures

2.8 Therapeutic Drug Monitoring (TDM) and Dose Titration for Tuberous Sclerosis Complex (TSC)-Associated Subependymal Giant Cell Astrocytoma (SEGA) and TSC-Associated Partial-Onset Seizures

2.9 Dosage Modifications for Adverse Reactions

2.10 Dosage Modifications for Hepatic Impairment

2.11 Dosage Modifications for P-gp and CYP3A4 Inhibitors

2.12 Dosage Modifications for P-gp and CYP3A4 Inducers

2.13 Administration and Preparation

### 3 DOSAGE FORMS AND STRENGTHS

### 4 CONTRAINDICATIONS

### 5 WARNINGS AND PRECAUTIONS

5.1 Non-infectious Pneumonitis

5.2 Infections

5.3 Severe Hypersensitivity Reactions

- 5.4 Angioedema With Concomitant Use of Angiotensin-Converting Enzyme (ACE) Inhibitors
- 5.5 Stomatitis
- 5.6 Renal Failure
- 5.7 Risk of Impaired Wound Healing
- 5.9 Metabolic Disorders
- 5.10 Myelosuppression
- 5.11 Risk of Infection or Reduced Immune Response With Vaccination
- 5.12 Radiation Sensitization and Radiation Recall
- 5.13 Embryo-Fetal Toxicity

## **6 ADVERSE REACTIONS**

- 6.1 Clinical Trials Experience
- 6.2 Postmarketing Experience

## **7 DRUG INTERACTIONS**

- 7.1 Effect of Other Drugs on Everolimus Tablets for Oral Suspension
- 7.2 Effects of Combination Use of Angiotensin-Converting Enzyme (ACE) Inhibitors

## **8 USE IN SPECIFIC POPULATIONS**

- 8.1 Pregnancy
- 8.2 Lactation
- 8.3 Females and Males of Reproductive Potential
- 8.4 Pediatric Use
- 8.6 Hepatic Impairment

## **11 DESCRIPTION**

## **12 CLINICAL PHARMACOLOGY**

- 12.1 Mechanism of Action
- 12.2 Pharmacodynamics
- 12.3 Pharmacokinetics

## **13 NONCLINICAL TOXICOLOGY**

- 13.1 Carcinogenesis, Mutagenesis, Impairment of Fertility
- 13.2 Animal Toxicology and/or Pharmacology

## **14 CLINICAL STUDIES**

- 14.5 Tuberos Sclerosis Complex (TSC)-Associated Subependymal Giant Cell Astrocytoma (SEGA)
- 14.6 Tuberos Sclerosis Complex (TSC)-Associated Partial-Onset Seizures

## **15 REFERENCES**

## **16 HOW SUPPLIED/STORAGE AND HANDLING**

## **17 PATIENT COUNSELING INFORMATION**

\* Sections or subsections omitted from the full prescribing information are not listed.

---

## **FULL PRESCRIBING INFORMATION**

### **1 INDICATIONS AND USAGE**

#### **1.5 Tuberos Sclerosis Complex (TSC)-Associated Subependymal Giant Cell Astrocytoma (SEGA)**

Everolimus tablets for oral suspension are indicated in adult and pediatric patients aged 1 year and older with TSC for the treatment of SEGA that requires therapeutic intervention but cannot be curatively resected.

## **1.6 Tuberos Sclerosis Complex (TSC)-Associated Partial-Onset Seizures**

Everolimus tablets for oral suspension are indicated for the adjunctive treatment of adult and pediatric patients aged 2 years and older with TSC-associated partial-onset seizures.

## **2 DOSAGE AND ADMINISTRATION**

### **2.1 Important Dosage Information**

- Do not combine AFINITOR and everolimus tablets for oral suspension to achieve the total dose.
- Modify the dosage for patients with hepatic impairment or for patients taking drugs that inhibit or induce P-glycoprotein (P-gp) and CYP3A4 [see *Dosage and Administration* (2.10, 2.11, 2.12)].

### **2.6 Recommended Dosage for Tuberos Sclerosis Complex (TSC)-Associated Subependymal Giant Cell Astrocytoma (SEGA)**

The recommended starting dosage of everolimus tablets for oral suspension is 4.5 mg/m<sup>2</sup> orally once daily until disease progression or unacceptable toxicity [see *Dosage and Administration* (2.8)].

### **2.7 Recommended Dosage for Tuberos Sclerosis Complex (TSC)-Associated Partial-Onset Seizures**

The recommended starting dosage of everolimus tablets for oral suspension is 5 mg/m<sup>2</sup> orally once daily until disease progression or unacceptable toxicity [see *Dosage and Administration* (2.8)].

### **2.8 Therapeutic Drug Monitoring (TDM) and Dose Titration for Tuberos Sclerosis Complex (TSC)-Associated Subependymal Giant Cell Astrocytoma (SEGA) and TSC-Associated Partial-Onset Seizures**

- Monitor everolimus whole blood trough concentrations at time points recommended in Table 1.
- Titrate the dose to attain trough concentrations of 5 ng/mL to 15 ng/mL.
- Adjust the dose using the following equation:

New dose\* = current dose x (target concentration divided by current concentration)

\*The maximum dose increment at any titration must not exceed 5 mg. Multiple dose titrations may be required to attain the target trough concentration.

- When possible, use the same assay and laboratory for TDM throughout treatment.

#### **Table 1: Recommended Timing of Therapeutic Drug Monitoring**

---

<b>Event</b>	<b>When to Assess Trough Concentrations After Event</b>
Initiation of everolimus tablets for oral suspension	1 to 2 weeks
Modification of everolimus tablets for oral suspension dose	1 to 2 weeks
Switch between AFINITOR and everolimus tablets for oral suspension	1 to 2 weeks
Initiation or discontinuation of P-gp and moderate CYP3A4 inhibitor	2 weeks
Initiation or discontinuation of P-gp and strong CYP3A4 inducer	2 weeks
Change in hepatic function	2 weeks
Stable dose with changing body surface area (BSA)	Every 3 to 6 months
Stable dose with stable BSA	Every 6 to 12 months

Abbreviation: P-gp, P-glycoprotein.

## 2.9 Dosage Modifications for Adverse Reactions

Table 2 summarizes recommendations for dosage modifications of everolimus tablets for oral suspension for the management of adverse reactions.

**Table 2: Recommended Dosage Modifications for Everolimus Tablets for Oral Suspension for Adverse Reactions**

<b>Adverse Reaction</b>	<b>Severity</b>	<b>Dosage Modification</b>
Non-infectious pneumonitis <i>[see Warnings and Precautions (5.1)]</i>	Grade 2	Withhold until improvement to Grade 0 or 1. Resume at 50% of previous dose; change to every other day dosing if the reduced dose is lower than the lowest available strength.  Permanently discontinue if toxicity does not resolve or improve to Grade 1 within 4 weeks.
	Grade 3	Withhold until improvement to Grade 0 or 1. Resume at 50% of previous dose; change to every other day dosing if the reduced dose is lower than the lowest available strength.  If toxicity recurs at Grade 3, permanently discontinue.
	Grade 4	Permanently discontinue.
Stomatitis <i>[see Warnings and Precautions (5.5)]</i>	Grade 2	Withhold until improvement to Grade 0 or 1. Resume at same dose.  If recurs at Grade 2, withhold until improvement to Grade 0 or 1. Resume at 50% of previous dose; change to every other day dosing if the reduced dose is lower than the lowest available strength.
	Grade 3	Withhold until improvement to Grade 0 or 1. Resume

		at 50% of previous dose; change to every other day dosing if the reduced dose is lower than the lowest available strength.
	Grade 4	Permanently discontinue.
Metabolic events (e.g., hyperglycemia, dyslipidemia) [see Warnings and Precautions (5.9)]	Grade 3	Withhold until improvement to Grade 0, 1, or 2. Resume at 50% of previous dose; change to every other day dosing if the reduced dose is lower than the lowest available strength.
	Grade 4	Permanently discontinue.
Other non- hematologic toxicities	Grade 2	If toxicity becomes intolerable, withhold until improvement to Grade 0 or 1. Resume at same dose.
		If toxicity recurs at Grade 2, withhold until improvement to Grade 0 or 1. Resume at 50% of previous dose; change to every other day dosing if the reduced dose is lower than the lowest available strength.
	Grade 3	Withhold until improvement to Grade 0 or 1. Consider resuming at 50% of previous dose; change to every other day dosing if the reduced dose is lower than the lowest available strength.  If recurs at Grade 3, permanently discontinue.
	Grade 4	Permanently discontinue.
Thrombocytopenia [see Warnings and Precautions (5.10)]	Grade 2	Withhold until improvement to Grade 0 or 1. Resume at same dose.
	Grade 3 <b>OR</b> Grade 4	Withhold until improvement to Grade 0 or 1. Resume at 50% of previous dose; change to every other day dosing if the reduced dose is lower than the lowest available strength.
Neutropenia [see Warnings and Precautions (5.10)]	Grade 3	Withhold until improvement to Grade 0, 1, or 2. Resume at same dose.
	Grade 4	Withhold until improvement to Grade 0, 1, or 2. Resume at 50% of previous dose; change to every other day dosing if the reduced dose is lower than the lowest available strength.
Febrile neutropenia [see Warnings and Precautions (5.10)]	Grade 3	Withhold until improvement to Grade 0, 1, or 2, and no fever. Resume at 50% of previous dose; change to every other day dosing if the reduced dose is lower than the lowest available strength.
	Grade 4	Permanently discontinue.

## 2.10 Dosage Modifications for Hepatic Impairment

The recommended dosages of everolimus tablets for oral suspension for patients with hepatic impairment are described in Table 3 [see *Use in Specific Populations (8.6)*]:

**Table 3: Recommended Dosage Modifications for Patients With Hepatic**

## Impairment

Indication	Dose Modification for Everolimus Tablets for Oral Suspension
TSC-Associated SEGA and TSC-Associated Partial-Onset Seizures	<ul style="list-style-type: none"> <li>• Severe hepatic impairment (Child-Pugh class C) – 2.5 mg/m<sup>2</sup> orally once daily.</li> <li>• Adjust dose based on everolimus trough concentrations as recommended [see <i>Dosage and Administration (2.8)</i>].</li> </ul>

Abbreviations: SEGA, Subependymal Giant Cell Astrocytoma; TSC, Tuberous Sclerosis Complex.

### 2.11 Dosage Modifications for P-gp and CYP3A4 Inhibitors

- Avoid the concomitant use of P-gp and strong CYP3A4 inhibitors [see *Drug Interactions (7.1)*].
- Avoid ingesting grapefruit and grapefruit juice.
- Reduce the dose for patients taking everolimus tablets for oral suspension with a P-gp and moderate CYP3A4 inhibitor as recommended in Table 4 [see *Drug Interactions (7.1)*, *Clinical Pharmacology (12.3)*].

**Table 4: Recommended Dosage Modifications for Concurrent Use of Everolimus Tablets for Oral Suspension With a P-gp and Moderate CYP3A4 Inhibitor**

Indication	Dose Modification for Everolimus Tablets for Oral Suspension
TSC-Associated SEGA and TSC-Associated Partial-Onset Seizures	<ul style="list-style-type: none"> <li>• Reduce the daily dose by 50%.</li> <li>• Change to every other day dosing if the reduced dose is lower than the lowest available strength.</li> <li>• Resume dose administered prior to inhibitor initiation, once the inhibitor is discontinued for 3 days.</li> <li>• Assess trough concentrations when initiating and discontinuing the inhibitor [see <i>Dosage and Administration (2.8)</i>].</li> </ul>

### 2.12 Dosage Modifications for P-gp and CYP3A4 Inducers

- Avoid concomitant use of St. John's Wort (*Hypericum perforatum*).
- Increase the dose for patients taking everolimus tablets for oral suspension with a P-gp and strong CYP3A4 inducer as recommended in Table 5 [see *Drug Interactions (7.1)*, *Clinical Pharmacology (12.3)*].

**Table 5: Recommended Dosage Modifications for Concurrent Use of Everolimus Tablets for Oral Suspension With P-gp and Strong CYP3A4 Inducers**

Indication	Dose Modification for Everolimus Tablets for Oral Suspension
TSC-Associated SEGA and TSC-Associated Partial-Onset Seizures	<ul style="list-style-type: none"> <li>• Double the daily dose using increments of 5 mg or less. Multiple increments may be required.</li> <li>• Addition of another strong CYP3A4 inducer in a patient already receiving treatment with a strong CYP3A4 inducer may not require additional dosage modification.</li> <li>• Assess trough concentrations when initiating and discontinuing the inducer [see <i>Dosage and Administration (2.8)</i>].</li> <li>• Resume the dose administered before starting any inducer, once all inducers are discontinued for 5 days.</li> </ul>

### 2.13 Administration and Preparation

- Administer everolimus tablets for oral suspension at the same time each day.
- Administer everolimus tablets for oral suspension consistently either with or without food [see *Clinical Pharmacology (12.3)*].
- If a dose of everolimus tablets for oral suspension is missed, it can be administered up to 6 hours after the time it is normally administered. After more than 6 hours, the dose should be skipped for that day. The next day, everolimus tablets for oral suspension should be administered at its usual time. Double doses should not be administered to make up for the dose that was missed.

#### **Everolimus Tablets for Oral Suspension:**

- Wear gloves to avoid possible contact with everolimus when preparing suspensions of everolimus tablets for oral suspension for another person.
- Administer as a suspension only.
- Administer suspension immediately after preparation. Discard suspension if not administered within 60 minutes after preparation.
- Prepare suspension in water only.

#### *Using an Oral Syringe to Prepare Oral Suspension:*

- Place the prescribed dose into a 10-mL syringe. Do not exceed a total of 10 mg per syringe. If higher doses are required, prepare an additional syringe. Do not break or crush tablets.
- Draw approximately 5 mL of water and 4 mL of air into the syringe.
- Place the filled syringe into a container (tip up) for 3 minutes, until the tablets are in suspension.
- Gently invert the syringe 5 times immediately prior to administration.



- After administration of the prepared suspension, draw approximately 5 mL of water and 4 mL of air into the same syringe, and swirl the contents to suspend remaining particles. Administer the entire contents of the syringe.

#### *Using a Small Drinking Glass to Prepare Oral Suspension:*

- Place the prescribed dose into a small drinking glass (maximum size 100 mL) containing approximately 25 mL of water. Do not exceed a total of 10 mg per glass. If higher doses are required, prepare an additional glass. Do not break or crush tablets.
- Allow 3 minutes for suspension to occur.
- Stir the contents gently with a spoon, immediately prior to drinking.
- After administration of the prepared suspension, add 25 mL of water and stir with the same spoon to re-suspend remaining particles. Administer the entire contents of the glass.

### **3 DOSAGE FORMS AND STRENGTHS**

Everolimus Tablets for Oral Suspension are available containing 2 mg, 3 mg, or 5 mg of everolimus.

- The 2 mg tablets are white to slightly yellow, round, unscored tablets debossed with **M** on one side of the tablet and **EVD** over **2** on the other side.
- The 3 mg tablets are white to slightly yellow, round, unscored tablets debossed with **M** on one side of the tablet and **EVD** over **3** on the other side.
- The 5 mg tablets are white to slightly yellow, round, unscored tablets debossed with **M** on one side of the tablet and **EVD** over **5** on the other side.

### **4 CONTRAINDICATIONS**

Everolimus tablets for oral suspension are contraindicated in patients with clinically significant hypersensitivity to everolimus or to other rapamycin derivatives [see *Warnings and Precautions (5.3)*].

### **5 WARNINGS AND PRECAUTIONS**

#### **5.1 Non-infectious Pneumonitis**

Non-infectious pneumonitis is a class effect of rapamycin derivatives. Non-infectious pneumonitis was reported in up to 19% of patients treated with everolimus tablets for oral suspension in clinical trials, some cases were reported with pulmonary hypertension (including pulmonary arterial hypertension) as a secondary event. The incidence of Grade 3 and 4 non-infectious pneumonitis was up to 4% and up to 0.2%, respectively [see *Adverse Reactions (6.1)*]. Fatal outcomes have been observed.

Consider a diagnosis of non-infectious pneumonitis in patients presenting with non-specific respiratory signs and symptoms. Consider opportunistic infections, such as pneumocystis jiroveci pneumonia (PJP) in the differential diagnosis. Advise patients to report promptly any new or worsening respiratory symptoms.

Continue everolimus tablets for oral suspension without dose alteration in patients who develop radiological changes suggestive of non-infectious pneumonitis and have few or no symptoms. Imaging appears to overestimate the incidence of clinical pneumonitis.

For Grade 2 to 4 non-infectious pneumonitis, withhold or permanently discontinue everolimus tablets for oral suspension based on severity [see *Dosage and Administration (2.9)*]. Corticosteroids may be indicated until clinical symptoms resolve. Administer prophylaxis for PJP when concomitant use of corticosteroids or other immunosuppressive agents are required. The development of pneumonitis has been reported even at a reduced dose.

## **5.2 Infections**

Everolimus tablets for oral suspension have immunosuppressive properties and may predispose patients to bacterial, fungal, viral, or protozoal infections, including infections with opportunistic pathogens [see *Adverse Reactions (6.1)*]. Localized and systemic infections, including pneumonia, mycobacterial infections, other bacterial infections, invasive fungal infections (e.g., aspergillosis, candidiasis, or PJP), and viral infections (e.g., reactivation of hepatitis B virus) have occurred. Some of these infections have been severe (e.g., sepsis, septic shock, or resulting in multisystem organ failure) or fatal. The incidence of Grade 3 and 4 infections was up to 10% and up to 3%, respectively. The incidence of serious infections was reported at a higher frequency in patients < 6 years of age [see *Use in Specific Populations (8.4)*].

Complete treatment of preexisting invasive fungal infections prior to starting treatment. Monitor for signs and symptoms of infection. Withhold or permanently discontinue everolimus tablets for oral suspension based on severity of infection [see *Dosage and Administration (2.9)*].

Administer prophylaxis for PJP when concomitant use of corticosteroids or other immunosuppressive agents are required.

## **5.3 Severe Hypersensitivity Reactions**

Hypersensitivity reactions to everolimus tablets for oral suspension have been observed and include anaphylaxis, dyspnea, flushing, chest pain, and angioedema (e.g., swelling of the airways or tongue, with or without respiratory impairment) [see *Contraindications (4)*]. The incidence of Grade 3 hypersensitivity reactions was up to 1%. Permanently discontinue everolimus tablets for oral suspension for the development of clinically significant hypersensitivity.

## **5.4 Angioedema With Concomitant Use of Angiotensin-Converting Enzyme (ACE) Inhibitors**

Patients taking concomitant ACE inhibitors with everolimus tablets for oral suspension may be at increased risk for angioedema (e.g., swelling of the airways or tongue, with or without respiratory impairment). In a pooled analysis of randomized double-blind oncology clinical trials, the incidence of angioedema in patients taking AFINITOR with an ACE inhibitor was 6.8% compared to 1.3% in the control arm with an ACE inhibitor. Permanently discontinue everolimus tablets for oral suspension for angioedema.

## **5.5 Stomatitis**

Stomatitis, including mouth ulcers and oral mucositis, has occurred in patients treated with everolimus tablets for oral suspension at an incidence ranging from 44% to 78% across clinical trials. Grades 3-4 stomatitis was reported in 4% to 9% of patients. Stomatitis most often occurs within the first 8 weeks of treatment. When starting everolimus tablets for oral suspension, initiating dexamethasone alcohol-free oral solution as a swish and spit mouthwash reduces the incidence and severity of stomatitis. If stomatitis does occur, mouthwashes and/or other topical treatments are recommended. Avoid alcohol-, hydrogen peroxide-, iodine-, or thyme- containing products, as they may exacerbate the condition. Do not administer antifungal agents, unless fungal infection has been diagnosed.

## **5.6 Renal Failure**

Cases of renal failure (including acute renal failure), some with a fatal outcome, have occurred in patients taking AFINITOR. Elevations of serum creatinine and proteinuria have been reported in patients taking everolimus tablets for oral suspension [see *Adverse Reactions (6.1)*]. The incidence of Grade 3 and 4 elevations of serum creatinine was up to 2% and up to 1%, respectively. The incidence of Grade 3 and 4 proteinuria was up to 1% and up to 0.5%, respectively. Monitor renal function prior to starting everolimus tablets for oral suspension and annually thereafter. Monitor renal function at least every 6 months in patients who have additional risk factors for renal failure.

## **5.7 Risk of Impaired Wound Healing**

Impaired wound healing can occur in patients who receive drugs that inhibit the VEGF signaling pathway. Therefore, everolimus tablets for oral suspension have the potential to adversely affect wound healing.

Withhold everolimus tablets for oral suspension for at least 1 week prior to elective surgery. Do not administer for at least 2 weeks following major surgery and until adequate wound healing. The safety of resumption of treatment upon resolution of wound healing complications has not been established.

## **5.9 Metabolic Disorders**

Hyperglycemia, hypercholesterolemia, and hypertriglyceridemia have been reported in patients taking everolimus tablets for oral suspension at an incidence up to 75%, 86%, and 73%, respectively. The incidence of these Grade 3 and 4 laboratory abnormalities was up to 15% and up to 0.4%, respectively [see *Adverse Reactions (6.1)*]. In non-diabetic patients, monitor fasting serum glucose prior to starting everolimus tablets for oral suspension and annually thereafter. In diabetic patients, monitor fasting serum glucose more frequently as clinically indicated. Monitor lipid profile prior to starting everolimus tablets for oral suspension and annually thereafter. When possible, achieve optimal glucose and lipid control prior to starting everolimus tablets for oral suspension. For Grade 3 to 4 metabolic events, withhold or permanently discontinue everolimus tablets for oral suspension based on severity [see *Dosage and Administration (2.9)*].

## **5.10 Myelosuppression**

Anemia, lymphopenia, neutropenia, and thrombocytopenia have been reported in patients taking everolimus tablets for oral suspension. The incidence of these Grade 3 and 4 laboratory abnormalities was up to 16% and up to 2%, respectively [see *Adverse*

*Reactions (6.1)]*. Monitor complete blood count (CBC) prior to starting everolimus tablets for oral suspension every 6 months for the first year of treatment and annually thereafter. Withhold or permanently discontinue everolimus tablets for oral suspension based on severity [*see Dosage and Administration (2.9)]*.

### **5.11 Risk of Infection or Reduced Immune Response With Vaccination**

The safety of immunization with live vaccines during everolimus tablets for oral suspension therapy has not been studied. Due to the potential increased risk of infection, avoid the use of live vaccines and close contact with individuals who have received live vaccines during treatment with everolimus tablets for oral suspension. Due to the potential increased risk of infection or reduced immune response with vaccination, complete the recommended childhood series of vaccinations according to American Council on Immunization Practices (ACIP) guidelines prior to the start of therapy. An accelerated vaccination schedule may be appropriate.

### **5.12 Radiation Sensitization and Radiation Recall**

Radiation sensitization and recall, in some cases severe, involving cutaneous and visceral organs (including radiation esophagitis and pneumonitis) have been reported in patients treated with radiation prior to, during, or subsequent to everolimus tablets for oral suspension treatment [*see Adverse Reactions (6.2)]*.

Monitor patients closely when everolimus tablets for oral suspension are administered during or sequentially with radiation treatment.

### **5.13 Embryo-Fetal Toxicity**

Based on animal studies and the mechanism of action, everolimus tablets for oral suspension can cause fetal harm when administered to a pregnant woman. In animal studies, everolimus caused embryo-fetal toxicities in rats when administered during the period of organogenesis at maternal exposures that were lower than human exposures at the clinical dose of 10 mg once daily. Advise pregnant women of the potential risk to a fetus. Advise female patients of reproductive potential to avoid becoming pregnant and to use effective contraception during treatment with everolimus tablets for oral suspension and for 8 weeks after the last dose. Advise male patients with female partners of reproductive potential to use effective contraception during treatment with everolimus tablets for oral suspension and for 4 weeks after the last dose [*see Use in Specific Populations (8.1, 8.3)]*.

## **6 ADVERSE REACTIONS**

The following serious adverse reactions are described elsewhere in the labeling:

- Non-Infectious Pneumonitis [*see Warnings and Precautions (5.1)]*
- Infections [*see Warnings and Precautions (5.2)]*
- Severe Hypersensitivity Reactions [*see Warnings and Precautions (5.3)]*
- Angioedema with Concomitant Use of ACE inhibitors [*see Warnings and Precautions (5.4)]*
- Stomatitis [*see Warnings and Precautions (5.5)]*
- Renal Failure [*see Warnings and Precautions (5.6)]*
- Impaired Wound Healing [*see Warnings and Precautions (5.7)]*

- Metabolic Disorders [see Warnings and Precautions (5.9)]
- Myelosuppression [see Warnings and Precautions (5.10)]
- Radiation Sensitization and Radiation Recall [see Warnings and Precautions (5.12)]

## 6.1 Clinical Trials Experience

Because clinical trials are conducted under widely varying conditions, the adverse reaction rates observed cannot be directly compared to rates in other trials and may not reflect the rates observed in clinical practice.

### **TSC-Associated Subependymal Giant Cell Astrocytoma (SEGA)**

The data described below are based on a randomized (2:1), double-blind, placebo-controlled trial (EXIST-1) of AFINITOR in 117 patients with SEGA and TSC. The median age of patients was 9.5 years (0.8 to 26 years), 93% were white, and 57% were male. The median duration of blinded study treatment was 52 weeks (24 to 89 weeks) for patients receiving AFINITOR.

The most common adverse reactions reported for AFINITOR (incidence  $\geq$  30%) were stomatitis and respiratory tract infection. The most common Grade 3-4 adverse reactions (incidence  $\geq$  2%) were stomatitis, pyrexia, pneumonia, gastroenteritis, aggression, agitation, and amenorrhea. The most common laboratory abnormalities (incidence  $\geq$  50%) were hypercholesterolemia and elevated partial thromboplastin time. The most common Grade 3-4 laboratory abnormality (incidence  $\geq$  3%) was neutropenia.

There were no adverse reactions resulting in permanent discontinuation. Dose adjustments (interruptions or reductions) due to adverse reactions occurred in 55% of AFINITOR-treated patients. The most common adverse reaction leading to AFINITOR dose adjustment was stomatitis.

Adverse reactions reported with an incidence of  $\geq$  10% for patients receiving AFINITOR and occurring more frequently with AFINITOR than with placebo are reported in Table 16. Laboratory abnormalities are presented in Table 17.

**Table 16: Adverse Reactions Reported in  $\geq$  10% of AFINITOR-Treated Patients With TSC-Associated SEGA in EXIST-1**

	AFINITOR N = 78		Placebo N = 39	
	All Grades %	Grade 3-4 %	All Grades %	Grade 3-4 %
<b>Gastrointestinal</b>				
Stomatitis*	62	9 <sup>†</sup>	26	3 <sup>†</sup>
Vomiting	22	1 <sup>†</sup>	13	0
Diarrhea	17	0	5	0
Constipation	10	0	3	0
<b>Infections</b>				
Respiratory tract infection <sup>‡</sup>	31	3	23	0
Gastroenteritis <sup>§</sup>	10	5	3	0

Pharyngitis streptococcal	10	0	3	0
<b>General</b>				
Pyrexia	23	6 <sup>†</sup>	18	3 <sup>†</sup>
Fatigue	14	0	3	0
<b>Psychiatric</b>				
Anxiety, aggression or other behavioral disturbance <sup>¶</sup>	21	5 <sup>†</sup>	3	0
<b>Skin and subcutaneous tissue</b>				
Rash <sup>#</sup>	21	0	8	0
Acne	10	0	5	0

Grading according to NCI CTCAE Version 3.0.

\* Includes mouth ulceration, stomatitis, and lip ulceration.

† No Grade 4 adverse reactions were reported.

‡ Includes respiratory tract infection, upper respiratory tract infection, and respiratory tract infection viral.

§ Includes gastroenteritis, gastroenteritis viral, and gastrointestinal infection.

¶ Includes agitation, anxiety, panic attack, aggression, abnormal behavior, and obsessive compulsive disorder.

# Includes rash, rash generalized, rash macular, rash maculo-papular, rash papular, dermatitis allergic, and urticaria.

Amenorrhea occurred in 17% of AFINITOR-treated females aged 10 to 55 years (3 of 18). For this same group of AFINITOR-treated females, the following menstrual abnormalities were reported: dysmenorrhea (6%), menorrhagia (6%), metrorrhagia (6%), and unspecified menstrual irregularity (6%).

The following additional adverse reactions occurred in less than 10% of AFINITOR-treated patients: nausea (8%), pain in extremity (8%), insomnia (6%), pneumonia (6%), epistaxis (5%), hypersensitivity (3%), increased blood luteinizing hormone (LH) levels (1%), and pneumonitis (1%).

**Table 17: Selected Laboratory Abnormalities Reported in AFINITOR-Treated Patients With TSC-Associated SEGA in EXIST-1**

	AFINITOR N = 78		Placebo N = 39	
	All Grades %	Grade 3-4 %	All Grades %	Grade 3-4 %
<b>Hematology</b>				
Elevated partial thromboplastin time	72	3*	44	5*
Neutropenia	46	9*	41	3*
Anemia	41	0	21	0
<b>Chemistry</b>				
Hypercholesterolemia	81	0	39	0
Elevated AST	33	0	0	0
Hypertriglyceridemia	27	0	15	0

Elevated ALT	18	0	3	0
Hypophosphatemia	9	1*	3	0

Grading according to NCI CTCAE Version 3.0.

\* No Grade 4 laboratory abnormalities were reported.

Updated safety information from 111 patients treated with AFINITOR for a median duration of 47 months identified the following additional notable adverse reactions and selected laboratory abnormalities: decreased appetite (14%), hyperglycemia (13%), hypertension (11%), urinary tract infection (9%), decreased fibrinogen (8%), cellulitis (6%), abdominal pain (5%), decreased weight (5%), elevated creatinine (5%), and azoospermia (1%).

### ***TSC-Associated Partial-Onset Seizures***

The data described below are based on the 18-week Core phase of a randomized, double-blind, multicenter, three-arm trial (EXIST-3) comparing two everolimus trough levels (3-7 ng/mL and 9-15 ng/mL) to placebo as adjunctive antiepileptic therapy in patients with TSC-associated partial-onset seizures. A total of 366 patients were randomized to everolimus tablets for oral suspension low trough (LT) (n = 117), everolimus tablets for oral suspension high trough (HT) (n = 130), or placebo (n = 119). The median age of patients was 10 years (2.2 to 56 years; 28% were < 6 years, 31% were 6 to < 12 years, 22% were 12 to < 18 years, and 18% were ≥ 18 years), 65% were white, and 52% were male. Patients received between one and three concomitant antiepileptic drugs.

The most common adverse reaction reported for everolimus tablets for oral suspension in both arms (incidence ≥ 30%) was stomatitis. The most common Grade 3-4 adverse reactions (incidence ≥ 2%) were stomatitis, pneumonia, and irregular menstruation. The most common laboratory abnormality (incidence ≥ 50%) was hypercholesterolemia. The most common Grade 3-4 laboratory abnormality (incidence ≥ 2%) was neutropenia.

Adverse reactions leading to study drug discontinuation occurred in 5% and 3% of patients in the LT and HT arms, respectively. The most common adverse reaction (incidence ≥ 1%) leading to discontinuation was stomatitis. Dose adjustments (interruptions or reductions) due to adverse reactions occurred in 24% and 35% of patients in the LT and HT arms, respectively. The most common adverse reactions (incidence ≥ 3%) leading to dose adjustments in the everolimus tablets for oral suspension arms were stomatitis, pneumonia, and pyrexia.

Adverse reactions reported with an incidence of ≥ 10% for patients receiving everolimus tablets for oral suspension are presented in Table 18. Laboratory abnormalities are presented in Table 19.

**Table 18: Adverse Reactions Reported in ≥ 10% of Everolimus Tablets for Oral Suspension-Treated Patients With TSC-Associated Partial-Onset Seizures in EXIST-3**

	Everolimus Tablets for Oral Suspension		Placebo
	Target of 3-7 ng/mL	Target of 9-15 ng/mL	

	N = 117		N = 130		N = 119	
	All Grades %	Grade 3-4 %	All Grades %	Grade 3-4 %	All Grades %	Grade 3-4 %
<b>Gastrointestinal</b>						
Stomatitis*	55	3 <sup>†</sup>	64	4 <sup>†</sup>	9	0
Diarrhea	17	0	22	0	5	0
Vomiting	12	0	10	2 <sup>†</sup>	9	0
<b>Infections</b>						
Nasopharyngitis	14	0	16	0	16	0
Upper respiratory tract infection	13	0	15	0	13	0.8 <sup>†</sup>
<b>General</b>						
Pyrexia	20	0	14	0.8 <sup>†</sup>	5	0
<b>Respiratory, thoracic and mediastinal</b>						
Cough	11	0	10	0	3	0
<b>Skin and subcutaneous tissue</b>						
Rash	6	0	10	0	3	0

Grading according to NCI CTCAE version 4.03.

\* Includes stomatitis, mouth ulceration, aphthous ulcer, lip ulceration, tongue ulceration, mucosal inflammation, gingival pain.

† No Grade 4 adverse reactions were reported.

The following additional adverse reactions occurred in < 10% of everolimus tablets for oral suspension treated patients (% everolimus tablets for oral suspension LT, % everolimus tablets for oral suspension HT): decreased appetite (9%, 7%), pneumonia (2%, 4%), aggression (2%, 0.8%), proteinuria (0%, 2%), menorrhagia (0.9%, 0.8%), and pneumonitis (0%, 0.8%).

**Table 19: Selected Laboratory Abnormalities Reported in ≥ 10% Everolimus Tablets for Oral Suspension-Treated Patients With TSC-Associated Partial-Onset Seizures**

	Everolimus Tablets for Oral Suspension				Placebo	
	Target of 3-7 ng/mL N = 117		Target of 9-15 ng/mL N = 130		N = 119	
	All Grades %	Grade 3-4 %	All Grades %	Grade 3-4 %	All Grades %	Grade 3-4 %
<b>Hematology</b>						
Neutropenia	25	4*	37	6	23	7*
Anemia	27	0.9*	30	0	21	0.8*
Thrombocytopenia	12	0	15	0	6	0
<b>Chemistry</b>						
Hypercholesterolemia	86	0	85	0.8*	58	0



Hypertriglyceridemia	43	2*	39	2	22	0
Increased ALT	17	0	22	0	6	0
Increased AST	13	0	19	0	4	0
Hyperglycemia	19	0	18	0	17	0
Increased alkaline phosphatase	24	0	16	0	29	0
Hypophosphatemia	9	0.9*	16	2	3	0

Grading according to NCI CTCAE version 4.03.

\* No Grade 4 laboratory abnormalities were reported.

Updated safety information from 357 patients treated with everolimus tablets for oral suspension for a median duration of 48 weeks identified the following additional notable adverse reactions: hypersensitivity (0.6%), angioedema (0.3%), and ovarian cyst (0.3%).

## 6.2 Postmarketing Experience

The following adverse reactions have been identified during postapproval use of everolimus tablets for oral suspension. Because these reactions are reported voluntarily from a population of uncertain size, it is not always possible to reliably estimate frequency or establish a causal relationship to drug exposure:

- **Blood and Lymphatic Disorders:** Thrombotic microangiopathy
- **Cardiac:** Cardiac failure with some cases reported with pulmonary hypertension (including pulmonary arterial hypertension) as a secondary event
- **Gastrointestinal:** Acute pancreatitis
- **Hepatobiliary:** Cholecystitis and cholelithiasis
- **Infections:** Sepsis and septic shock
- **Nervous System:** Reflex sympathetic dystrophy
- **Vascular:** Arterial thrombotic events, lymphedema
- **Injury, Poisoning and Procedural Complications:** Radiation sensitization and radiation recall

## 7 DRUG INTERACTIONS

### 7.1 Effect of Other Drugs on Everolimus Tablets for Oral Suspension

#### **Inhibitors**

Avoid the concomitant use of P-gp and strong CYP3A4 inhibitors [see *Dosage and Administration (2.11)*, *Clinical Pharmacology (12.3)*].

Reduce the dose for patients taking everolimus tablets for oral suspension with a P-gp and moderate CYP3A4 inhibitor as recommended [see *Dosage and Administration (2.11)*, *Clinical Pharmacology (12.3)*].

#### **Inducers**

Increase the dose for patients taking everolimus tablets for oral suspension with a P-gp and strong CYP3A4 inducer as recommended [see *Dosage and Administration (2.12)*, *Clinical Pharmacology (12.3)*].

## **7.2 Effects of Combination Use of Angiotensin-Converting Enzyme (ACE) Inhibitors**

Patients taking concomitant ACE inhibitors with everolimus tablets for oral suspension may be at increased risk for angioedema. Avoid the concomitant use of ACE inhibitors with everolimus tablets for oral suspension [see *Warnings and Precautions (5.4)*].

## **8 USE IN SPECIFIC POPULATIONS**

### **8.1 Pregnancy**

#### ***Risk Summary***

Based on animal studies and the mechanism of action [see *Clinical Pharmacology (12.1)*], everolimus tablets for oral suspension can cause fetal harm when administered to a pregnant woman. There are limited case reports of AFINITOR use in pregnant women; however, these reports are not sufficient to inform about risks of birth defects or miscarriage. In animal studies, everolimus caused embryo-fetal toxicities in rats when administered during the period of organogenesis at maternal exposures that were lower than human exposures at the recommended dose of AFINITOR 10 mg orally once daily (see *Data*). Advise pregnant women of the potential risk to the fetus.

In the U.S. general population, the estimated background risk of major birth defects and miscarriage is 2% to 4% and 15% to 20% of clinically recognized pregnancies, respectively.

#### ***Data***

##### ***Animal Data***

In animal reproductive studies, oral administration of everolimus to female rats before mating and through organogenesis induced embryo-fetal toxicities, including increased resorption, pre-implantation and post-implantation loss, decreased numbers of live fetuses, malformation (e.g., sternal cleft), and retarded skeletal development. These effects occurred in the absence of maternal toxicities. Embryo-fetal toxicities in rats occurred at doses  $\geq 0.1$  mg/kg (0.6 mg/m<sup>2</sup>) with resulting exposures of approximately 4% of the human exposure at the recommended dose of AFINITOR 10 mg orally once daily based on area under the curve (AUC). In rabbits, embryo-toxicity evident as an increase in resorptions occurred at an oral dose of 0.8 mg/kg (9.6 mg/m<sup>2</sup>), approximately 1.6 times the recommended dose of AFINITOR 10 mg orally once daily or the median dose administered to patients with tuberous sclerosis complex (TSC)-associated subependymal giant cell astrocytoma (SEGA), and 1.3 times the median dose administered to patients with TSC-associated partial-onset seizures based on BSA. The effect in rabbits occurred in the presence of maternal toxicities.

In a pre- and post-natal development study in rats, animals were dosed from implantation through lactation. At the dose of 0.1 mg/kg (0.6 mg/m<sup>2</sup>), there were no adverse effects on delivery and lactation or signs of maternal toxicity; however, there were reductions in body weight (up to 9% reduction from the control) and in survival of offspring (~5% died or missing). There were no drug-related effects on the developmental parameters (morphological development, motor activity, learning, or

fertility assessment) in the offspring.

## **8.2 Lactation**

### ***Risk Summary***

There are no data on the presence of everolimus or its metabolites in human milk, the effects of everolimus on the breastfed infant or on milk production. Everolimus and its metabolites passed into the milk of lactating rats at a concentration 3.5 times higher than in maternal serum. Because of the potential for serious adverse reactions in breastfed infants from everolimus, advise women not to breastfeed during treatment with everolimus tablets for oral suspension and for 2 weeks after the last dose.

## **8.3 Females and Males of Reproductive Potential**

### ***Pregnancy Testing***

Verify the pregnancy status of females of reproductive potential prior to starting everolimus tablets for oral suspension [see *Use in Specific Populations (8.1)*].

### ***Contraception***

Everolimus tablets for oral suspension can cause fetal harm when administered to pregnant women [see *Use in Specific Populations (8.1)*].

#### *Females*

Advise female patients of reproductive potential to use effective contraception during treatment with everolimus tablets for oral suspension and for 8 weeks after the last dose.

#### *Males*

Advise male patients with female partners of reproductive potential to use effective contraception during treatment with everolimus tablets for oral suspension and for 4 weeks after the last dose.

### ***Infertility***

#### *Females*

Menstrual irregularities, secondary amenorrhea, and increases in luteinizing hormone (LH) and follicle stimulating hormone (FSH) occurred in female patients taking everolimus tablets for oral suspension. Based on these findings, everolimus tablets for oral suspension may impair fertility in female patients [see *Adverse Reactions (6.1)*, *Nonclinical Toxicology (13.1)*].

#### *Males*

Cases of reversible azoospermia have been reported in male patients taking AFINITOR. In male rats, sperm motility, sperm count, plasma testosterone levels and fertility were diminished at AUC similar to those of the clinical dose of AFINITOR 10 mg orally once daily. Based on these findings, everolimus tablets for oral suspension may impair fertility

in male patients [see *Nonclinical Toxicology (13.1)*].

## 8.4 Pediatric Use

### ***TSC-Associated SEGA***

The safety and effectiveness of everolimus tablets for oral suspension have been established in pediatric patients age 1 year and older with TSC-associated SEGA that requires therapeutic intervention but cannot be curatively resected. Use of everolimus tablets for oral suspension for this indication is supported by evidence from a randomized, double-blind, placebo-controlled trial in adult and pediatric patients (EXIST-1); an open-label, single-arm trial in adult and pediatric patients (Study 2485); and additional pharmacokinetic data in pediatric patients [see *Adverse Reactions (6.1)*, *Clinical Pharmacology (12.3)*, *Clinical Studies (14.5)*]. The safety and effectiveness of everolimus tablets for oral suspension have not been established in pediatric patients less than 1 year of age with TSC-associated SEGA.

In EXIST-1, the incidence of infections and serious infections were reported at a higher frequency in patients < 6 years of age. Ninety-six percent of 23 AFINITOR-treated patients < 6 years had at least one infection compared to 67% of 55 AFINITOR-treated patients ≥ 6 years. Thirty-five percent of 23 AFINITOR-treated patients < 6 years of age had at least 1 serious infection compared to 7% of 55 AFINITOR-treated patients ≥ 6 years.

Although a conclusive determination cannot be made due to the limited number of patients and lack of a comparator arm in the open label follow-up periods of EXIST-1 and Study 2485, AFINITOR did not appear to adversely impact growth and pubertal development in the 115 pediatric patients treated with AFINITOR for a median duration of 4.1 years.

### ***TSC-Associated Partial-Onset Seizures***

The safety and effectiveness of everolimus tablets for oral suspension has been established for the adjunctive treatment of pediatric patients aged 2 years and older with TSC-associated partial-onset seizures. Use of everolimus tablets for oral suspension for this indication is supported by evidence from a randomized, double-blind, placebo-controlled trial in adult and pediatric patients (EXIST-3) with additional pharmacokinetic data in pediatric patients [see *Adverse Reactions (6.1)*, *Clinical Pharmacology (12.3)*, *Clinical Studies (14.6)*]. The safety and effectiveness of everolimus tablets for oral suspension and AFINITOR have not been established for the adjunctive treatment of pediatric patients less than 2 years of age with TSC-associated partial-onset seizures.

The incidence of infections and serious infections were reported at a higher frequency in patients < 6 years of age compared to patients ≥ 6 years old. Seventy-seven percent of 70 everolimus tablets for oral suspension-treated patients < 6 years had at least one infection, compared to 53% of 177 everolimus tablets for oral suspension-treated patients ≥ 6 years. Sixteen percent of 70 everolimus tablets for oral suspension-treated patients < 6 years of age had at least 1 serious infection, compared to 4% of 177 everolimus tablets for oral suspension-treated patients ≥ 6 years of age. Two fatal cases due to infections were reported in pediatric patients.

## 8.6 Hepatic Impairment

Everolimus exposure may increase in patients with hepatic impairment [see *Clinical Pharmacology* (12.3)].

For patients with TSC-associated SEGA and TSC-associated partial-onset seizures who have severe hepatic impairment (Child-Pugh class C), reduce the starting dose of everolimus tablets for oral suspension as recommended and adjust the dose based on everolimus trough concentrations [see *Dosage and Administration* (2.8, 2.10)].

## 11 DESCRIPTION

Everolimus tablets for oral suspension are a kinase inhibitor.

The chemical name of everolimus is (3*S*,6*R*,7*E*,9*R*,10*R*,12*R*,14*S*,15*E*,17*E*,19*E*,21*S*,23*S*,26*R*,27*R*,34*aS*)-9,10,12,13,14,21,22,23,24,25,26,27,32,33,34,34*a*-Hexadecahydro-9,27-dihydroxy-3-[(1*R*)-2-[(1*S*,3*R*,4*R*)-4-(2-hydroxyethoxy)-3-methoxycyclohexyl]-1-methylethyl]-10,21-dimethoxy-6,8,12,14,20,26-hexamethyl-23,27-epoxy-3*H*-pyrido[2,1-*c*][1,4]oxaazacyclohentacontine-1,5,11,28,29(4*H*,6*H*,31*H*)-pentone. The molecular formula is C<sub>53</sub>H<sub>83</sub>NO<sub>14</sub> and the molecular weight is 958.2 g/mol. The structural formula is:

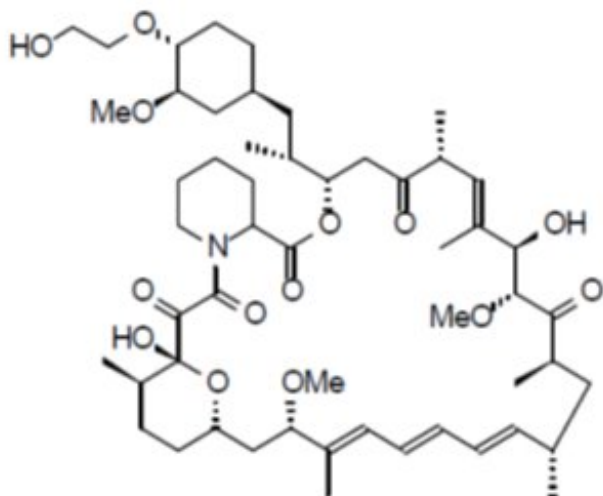

Everolimus tablets for oral suspension contain 2 mg, 3 mg, or 5 mg of everolimus and the following inactive ingredients: anhydrous lactose, butylated hydroxytoluene, croscarmellose sodium, crospovidone, hypromellose, lactose monohydrate, magnesium stearate, mannitol, microcrystalline cellulose and silicon dioxide.

## 12 CLINICAL PHARMACOLOGY

### 12.1 Mechanism of Action

Everolimus is an inhibitor of mammalian target of rapamycin (mTOR), a serine-threonine kinase, downstream of the PI3K/AKT pathway. The mTOR pathway is dysregulated in several human cancers and in tuberous sclerosis complex (TSC). Everolimus binds to an intracellular protein, FKBP-12, resulting in an inhibitory complex formation with mTOR

complex 1 (mTORC1) and thus inhibition of mTOR kinase activity. Everolimus reduced the activity of S6 ribosomal protein kinase (S6K1) and eukaryotic initiation factor 4E-binding protein (4E-BP1), downstream effectors of mTOR, involved in protein synthesis. S6K1 is a substrate of mTORC1 and phosphorylates the activation domain 1 of the estrogen receptor which results in ligand-independent activation of the receptor. In addition, everolimus inhibited the expression of hypoxia-inducible factor (e.g., HIF-1) and reduced the expression of vascular endothelial growth factor (VEGF). Inhibition of mTOR by everolimus has been shown to reduce cell proliferation, angiogenesis, and glucose uptake in *in vitro* and/or *in vivo* studies.

Two regulators of mTORC1 signaling are the oncogene suppressors tuberin-sclerosis complexes 1 and 2 (*TSC1*, *TSC2*). Loss or inactivation of either *TSC1* or *TSC2* leads to activation of downstream signaling. In TSC, a genetic disorder, inactivating mutations in either the *TSC1* or the *TSC2* gene lead to hamartoma formation throughout the body as well as seizures and epileptogenesis. Overactivation of mTOR results in neuronal dysplasia, aberrant axonogenesis and dendrite formation, increased excitatory synaptic currents, reduced myelination, and disruption of the cortical laminar structure causing abnormalities in neuronal development and function. Treatment with an mTOR inhibitor in animal models of mTOR dysregulation in the brain resulted in seizure suppression, prevention of the development of new-onset seizures, and prevention of premature death.

## **12.2 Pharmacodynamics**

### ***Exposure-Response Relationship***

In patients with TSC-associated subependymal giant cell astrocytoma (SEGA), the magnitude of the reduction in SEGA volume was correlated with the everolimus trough concentration.

In patients with TSC-associated partial-onset seizures, the magnitude of the reduction in absolute seizure frequency was correlated with the everolimus trough concentration.

### ***Cardiac Electrophysiology***

In a randomized, placebo-controlled, cross-over study, 59 healthy subjects were administered a single oral dose of AFINITOR (20 mg and 50 mg) and placebo. AFINITOR at single doses up to 50 mg did not prolong the QT/QTc interval.

## **12.3 Pharmacokinetics**

### ***Absorption***

In patients with TSC-associated SEGA, everolimus  $C_{min}$  was approximately dose-proportional within the dose range from 1.35 mg/m<sup>2</sup> to 14.4 mg/m<sup>2</sup>.

### ***Effect of Food***

In healthy subjects who received 9 mg of everolimus tablets for oral suspension, high-fat meals (containing approximately 1000 calories and 55 grams of fat) reduced everolimus AUC by 12% and  $C_{max}$  by 60% and low-fat meals (containing approximately 500 calories and 20 grams of fat) reduced everolimus AUC by 30% and  $C_{max}$  by 50%.

### *Relative Bioavailability*

The AUC<sub>inf</sub> of everolimus was equivalent between everolimus tablets for oral suspension and AFINITOR; the C<sub>max</sub> of everolimus in the everolimus tablets for oral suspension dosage form was 20% to 36% lower than that of AFINITOR. The predicted trough concentrations at steady-state were similar after daily administration.

### ***Distribution***

The blood-to-plasma ratio of everolimus, which is concentration-dependent over the range of 5 to 5000 ng/mL, is 17% to 73%. The amount of everolimus confined to the plasma is approximately 20% at blood concentrations observed in patients given AFINITOR 10 mg orally once daily. Plasma protein binding is approximately 74% both in healthy subjects and in patients with moderate hepatic impairment.

### ***Elimination***

The mean elimination half-life of everolimus is approximately 30 hours.

### *Metabolism*

Everolimus is a substrate of CYP3A4. Following oral administration, everolimus is the main circulating component in human blood. Six main metabolites of everolimus have been detected in human blood, including three monohydroxylated metabolites, two hydrolytic ring-opened products, and a phosphatidylcholine conjugate of everolimus. These metabolites were also identified in animal species used in toxicity studies, and showed approximately 100-times less activity than everolimus itself.

### *Excretion*

No specific elimination studies have been undertaken in cancer patients. Following the administration of a 3 mg single dose of radiolabeled everolimus in patients who were receiving cyclosporine, 80% of the radioactivity was recovered from the feces, while 5% was excreted in the urine. The parent substance was not detected in urine or feces.

### ***Specific Populations***

No relationship was apparent between oral clearance and age or sex in patients.

#### *Patients with Renal Impairment*

No significant influence of creatinine clearance (25 to 178 mL/min) was detected on oral clearance (CL/F) of everolimus.

#### *Patients with Hepatic Impairment*

Compared to normal subjects, there was a 1.8-fold, 3.2-fold, and 3.6-fold increase in AUC for subjects with mild (Child-Pugh class A), moderate (Child-Pugh class B), and severe (Child-Pugh class C) hepatic impairment, respectively. In another study, the average AUC of everolimus in subjects with moderate hepatic impairment (Child-Pugh class B) was twice that found in subjects with normal hepatic function [see *Dosage and Administration (2.10), Use in Specific Populations (8.6)*].

#### *Pediatric Patients*

In patients with TSC-associated SEGA or TSC-associated partial-onset seizures, the mean  $C_{\min}$  values normalized to  $\text{mg}/\text{m}^2$  dose in pediatric patients (< 18 years of age) were lower than those observed in adults, suggesting that everolimus clearance adjusted to BSA was higher in pediatric patients as compared to adults.

#### *Race or Ethnicity*

Based on a cross-study comparison, Japanese patients had on average exposures that were higher than non-Japanese patients receiving the same dose. Oral clearance (CL/F) is on average 20% higher in black patients than in white patients.

### **Drug Interaction Studies**

#### *Effect of CYP3A4 and P-glycoprotein (P-gp) Inhibitors on Everolimus*

Everolimus exposure increased when AFINITOR was coadministered with:

- ketoconazole (a P-gp and strong CYP3A4 inhibitor) -  $C_{\max}$  and AUC increased by 3.9- and 15-fold, respectively.
- erythromycin (a P-gp and moderate CYP3A4 inhibitor) -  $C_{\max}$  and AUC increased by 2- and 4.4-fold, respectively.
- verapamil (a P-gp and moderate CYP3A4 inhibitor) -  $C_{\max}$  and AUC increased by 2.3- and 3.5-fold, respectively.

#### *Effect of CYP3A4 and P-gp Inducers on Everolimus*

The coadministration of AFINITOR with rifampin, a P-gp and strong inducer of CYP3A4, decreased everolimus AUC by 63% and  $C_{\max}$  by 58% compared to AFINITOR alone [see *Dosage and Administration (2.12)*].

#### *Effect of Everolimus on CYP3A4 Substrates*

No clinically significant pharmacokinetic interactions were observed between AFINITOR and the HMG-CoA reductase inhibitors atorvastatin (a CYP3A4 substrate), pravastatin (a non-CYP3A4 substrate), and simvastatin (a CYP3A4 substrate).

The coadministration of an oral dose of midazolam (sensitive CYP3A4 substrate) with AFINITOR resulted in a 25% increase in midazolam  $C_{\max}$  and a 30% increase in midazolam  $\text{AUC}_{0-\text{inf}}$ .

#### *Effect of Everolimus on Antiepileptic Drugs (AEDs)*

Everolimus increased pre-dose concentrations of the carbamazepine, clobazam, oxcarbazepine, and clobazam's metabolite N-desmethyloclobazam by about 10%. Everolimus had no impact on pre-dose concentrations of AEDs that are substrates of CYP3A4 (e.g., clonazepam and zonisamide) or other AEDs, including valproic acid, topiramate, phenobarbital, and phenytoin.

## **13 NONCLINICAL TOXICOLOGY**

### **13.1 Carcinogenesis, Mutagenesis, Impairment of Fertility**



Administration of everolimus for up to 2 years did not indicate oncogenic potential in mice and rats up to the highest doses tested (0.9 mg/kg) corresponding, respectively to 3.9 and 0.2 times the estimated human exposure based on AUC at the recommended dose of AFINITOR 10 mg orally once daily.

Everolimus was not genotoxic in a battery of *in vitro* assays (Ames mutation test in *Salmonella*, mutation test in L5178Y mouse lymphoma cells, and chromosome aberration assay in V79 Chinese hamster cells). Everolimus was not genotoxic in an *in vivo* mouse bone marrow micronucleus test at doses up to 500 mg/kg/day (1500 mg/m<sup>2</sup>/day, approximately 255-fold the recommended dose of AFINITOR 10 mg orally once daily, and approximately 200-fold the median dose administered to patients with TSC-associated SEGA and TSC-associated partial-onset seizures, based on the BSA), administered as 2 doses, 24 hours apart.

Based on non-clinical findings, everolimus tablets for oral suspension may impair male fertility. In a 13-week male fertility study in rats, testicular morphology was affected at doses of 0.5 mg/kg and above. Sperm motility, sperm count, and plasma testosterone levels were diminished in rats treated with 5 mg/kg. The exposures at these doses (52 ng•hr/mL and 414 ng•hr/mL, respectively) were within the range of human exposure at the recommended dose of AFINITOR 10 mg orally once daily (560 ng•hr/mL) and resulted in infertility in the rats at 5 mg/kg. Effects on male fertility occurred at AUC<sub>0-24h</sub> values 10% to 81% lower than human exposure at the recommended dose of AFINITOR 10 mg orally once daily. After a 10-13 week non-treatment period, the fertility index increased from zero (infertility) to 60%.

Oral doses of everolimus in female rats at doses  $\geq$  0.1 mg/kg (approximately 4% the human exposure based on AUC at the recommended dose of AFINITOR 10 mg orally once daily) resulted in increased incidence of pre-implantation loss, suggesting that the drug may reduce female fertility.

## **13.2 Animal Toxicology and/or Pharmacology**

In juvenile rat toxicity studies, dose-related delayed attainment of developmental landmarks, including delayed eye-opening, delayed reproductive development in males and females and increased latency time during the learning and memory phases were observed at doses as low as 0.15 mg/kg/day.

## **14 CLINICAL STUDIES**

### **14.5 Tuberos Sclerosis Complex (TSC)-Associated Subependymal Giant Cell Astrocytoma (SEGA)**

#### **EXIST-1**

A randomized (2:1), double-blind, placebo-controlled trial (EXIST-1, NCT00789828) of AFINITOR was conducted in 117 pediatric and adult patients with SEGA and TSC. Eligible patients had at least one SEGA lesion  $\geq$  1 cm in longest diameter on MRI based on local radiology assessment and one or more of the following: serial radiological evidence of SEGA growth, a new SEGA lesion  $\geq$  1 cm in longest diameter, or new or worsening hydrocephalus. Patients randomized to the treatment arm received AFINITOR at a starting dose of 4.5 mg/m<sup>2</sup> daily, with subsequent dose adjustments as needed to achieve and maintain everolimus trough concentrations of 5 to 15 ng/mL as tolerated.

AFINITOR or matched placebo continued until disease progression or unacceptable toxicity. MRI scans for disease assessment were obtained at baseline, 12, 24, and 48 weeks, and annually thereafter.

The main efficacy outcome measure was SEGA response rate based on independent central radiology review. SEGA response was defined as a  $\geq 50\%$  reduction in the sum of SEGA volume relative to baseline, in the absence of unequivocal worsening of non-target SEGA lesions, a new SEGA lesion  $\geq 1$  cm, and new or worsening hydrocephalus. The primary analysis of SEGA response rate was limited to the blinded treatment period and conducted 6 months after the last patient was randomized. The analysis of SEGA response rate was stratified by use of enzyme-inducing antiepileptic drugs (EIAEDs) at randomization (yes vs. no).

Of the 117 patients enrolled, 78 were randomized to AFINITOR and 39 to placebo. The median age was 9.5 years (0.8 to 26 years); a total of 20 patients were  $< 3$  years, 54 patients were 3 to  $< 12$  years, 27 patients were 12 to  $< 18$  years, and 16 patients were  $\geq 18$  years; 57% were male, and 93% were white. At baseline, 18% of patients were receiving EIAEDs. Based on central radiology review at baseline, 98% of patients had at least one SEGA lesion  $\geq 1.0$  cm in longest diameter, 79% had bilateral SEGAs, 43% had  $\geq 2$  target SEGA lesions, 26% had growth in or into the inferior surface of the ventricle, 9% had evidence of growth beyond the subependymal tissue adjacent to the ventricle, and 7% had radiographic evidence of hydrocephalus. The median values for the sum of all target SEGA lesions at baseline were 1.63 cm<sup>3</sup> (0.18 to 25.15 cm<sup>3</sup>) and 1.30 cm<sup>3</sup> (0.32 to 9.75 cm<sup>3</sup>) in the AFINITOR and placebo arms, respectively. Eight (7%) patients had prior SEGA-related surgery. The median duration of follow-up was 8.4 months (4.6 to 17.2 months) at the time of primary analysis.

The SEGA response rate was statistically significantly higher in AFINITOR-treated patients (Table 25). At the time of the primary analysis, all SEGA responses were ongoing and the median duration of response was 5.3 months (2.1 to 8.4 months).

With a median follow-up of 8.4 months, SEGA progression was detected in 15.4% of the 39 patients randomized to receive placebo and none of the 78 patients randomized to receive AFINITOR. No patient in either treatment arm required surgical intervention.

**Table 25: Subependymal Giant Cell Astrocytoma Response Rate in TSC-Associated SEGA in EXIST-1**

	<b>AFINITOR N = 78</b>	<b>Placebo N = 39</b>	<b>p-value</b>
<b>Primary analysis</b>			
<b>SEGA response rate* - (%)</b>	<b>35</b>	<b>0</b>	<b>&lt; 0.0001</b>
95% CI	24, 46	0, 9	

\* Per independent central radiology review.

Patients randomized to placebo were permitted to receive AFINITOR at the time of SEGA progression or after the primary analysis, whichever occurred first. After the primary analysis, patients treated with AFINITOR underwent additional follow-up MRI scans to assess tumor status until discontinuation of treatment or completion of 4 years of follow-up after the last patient was randomized. A total of 111 patients (78 patients randomized to AFINITOR and 33 patients randomized to placebo) received at least one

dose of AFINITOR. Median duration of AFINITOR treatment and follow-up was 3.9 years (0.2 to 4.9 years).

By four years after the last patient was enrolled, 58% of the 111 patients treated with AFINITOR had a  $\geq 50\%$  reduction in SEGA volume relative to baseline, including 27 patients identified at the time of the primary analysis and 37 patients with a SEGA response after the primary analysis. The median time to SEGA response was 5.3 months (2.5 to 33.1 months). Twelve percent of the 111 patients treated with AFINITOR had documented disease progression by the end of the follow-up period and no patient required surgical intervention for SEGA during the study.

### **Study 2485**

Study 2485 (NCT00411619) was an open-label, single-arm trial conducted to evaluate the antitumor activity of AFINITOR 3 mg/m<sup>2</sup>/orally once daily in patients with SEGA and TSC. Serial radiological evidence of SEGA growth was required for entry. Tumor assessments were performed every 6 months for 60 months after the last patient was enrolled or disease progression, whichever occurred earlier. The major efficacy outcome measure was the reduction in volume of the largest SEGA lesion with 6 months of treatment, as assessed via independent central radiology review. Progression was defined as an increase in volume of the largest SEGA lesion over baseline that was  $\geq 25\%$  over the nadir observed on study.

A total of 28 patients received AFINITOR for a median duration of 5.7 years (5 months to 6.9 years); 82% of the 28 patients remained on AFINITOR for at least 5 years. The median age was 11 years (3 to 34 years), 61% male, 86% white.

At the primary analysis, 32% of the 28 patients (95% CI: 16%, 52%) had an objective response at 6 months, defined as at least a 50% decrease in volume of the largest SEGA lesion. At the completion of the study, the median duration of durable response was 12 months (3 months to 6.3 years).

By 60 months after the last patient was enrolled, 11% of the 28 patients had documented disease progression. No patient developed a new SEGA lesion while on AFINITOR. Nine additional patients were identified as having a  $\geq 50\%$  volumetric reduction in their largest SEGA lesion between 1 to 4 years after initiating AFINITOR, including 3 patients who had surgical resection with subsequent regrowth prior to receiving AFINITOR.

### **14.6 Tuberos Sclerosis Complex (TSC)-Associated Partial-Onset Seizures**

The efficacy of everolimus tablets for oral suspension as an adjunctive anti-epileptic drug (AED) was evaluated in a randomized, double-blind, multicenter, placebo-controlled study conducted in patients with TSC-associated partial-onset seizures (EXIST-3, NCT01713946). Patients with a history of inadequate control of partial-onset seizures despite treatment with  $\geq 2$  sequential AED regimens were randomized to receive placebo or everolimus tablets for oral suspension once daily at a dose to achieve a low trough (LT) level (3-7 ng/mL) or a high trough (HT) level (9-15 ng/mL). Randomization was stratified by age group (1 to < 6, 6 to < 12, 12 to < 18,  $\geq 18$  years). The study consisted of 3 phases: an 8-week Baseline observation phase; an 18-week double-blind, placebo-controlled Core phase (6-week titration period and a 12-week maintenance period), and an Extension phase of  $\geq 48$  weeks. Patients were required to have a diagnosis of TSC per the modified Gomez criteria, and  $\geq 16$  partial-onset seizures during

the Baseline phase while receiving a stable dose of 1 to 3 concomitant AEDs. The starting doses for everolimus tablets for oral suspension in the Core phase ranged from 3 to 6 mg/m<sup>2</sup> orally once daily, depending on age, in patients not receiving concomitant CYP3A4/P-gp inducers and from 5 to 9 mg/m<sup>2</sup> orally once daily, depending on age, in patients receiving concomitant CYP3A4/P-gp inducers. During the 6-week titration period, everolimus trough levels were assessed every 2 weeks and up to 3 dose adjustments were allowed to attempt to reach the targeted everolimus trough concentration range.

The major efficacy outcome measure was the percentage reduction in seizure frequency from the Baseline phase, during the maintenance period of the Core phase. Additional efficacy outcome measures included response rate, defined as at least a 50% reduction in seizure frequency from the Baseline phase during the maintenance period of the Core phase, and seizure freedom rate during the maintenance period of the Core phase.

A total of 366 patients were randomized to everolimus tablets for oral suspension LT (n = 117), everolimus tablets for oral suspension HT (n = 130) or placebo (n = 119). Median age was 10.1 years (2.2 to 56 years); 28% of patients were < 6 years, 31% were 6 to < 12 years, 22% were 12 to < 18 years, and 18% were ≥ 18 years). The majority were white (65%) and male (52%). The most common major features of TSC were cortical tubers (92%), hypomelanotic macules (84%), and subependymal nodules (83%). While 17% of the patients had SEGA, 42% had renal angiomyolipoma, and 9% had both SEGA and renal angiomyolipoma; no patients were receiving treatment with AFINITOR or everolimus tablets for oral suspension for these manifestations of TSC. During the Baseline phase, 65% of patients had complex partial seizures, 52% had secondarily generalized seizures, 19% had simple partial seizures, and 2% had generalized onset seizures. The median seizure frequency per week during the Baseline phase was 9.4 for all patients and 47% of patients were receiving 3 AEDs during the Baseline phase. The efficacy results are summarized in Table 26.

**Table 26: Percentage Reduction in Seizure Frequency and Response Rate in TSC-Associated Partial-Onset Seizures in EXIST-3**

	<b>Everolimus Tablets for Oral Suspension</b>		<b>Placebo</b>
	<b>Target of 3-7 ng/mL N = 117</b>	<b>Target of 9-15 ng/mL N = 130</b>	<b>N = 119</b>
<b>Seizures per week</b>			
Median at Baseline (Min, Max)	8.6 (1.4, 192.9)	9.5 (0.3, 218.4)	10.5 (1.3, 231.7)
Median at Core phase* (Min, Max)	6.8 (0.0, 193.5)	4.9 (0.0, 133.7)	8.5 (0.0, 217.7)
<b>Percentage reduction from Baseline to Core phase (Maintenance*)</b>			
Median	29.3	39.6	14.9
95% CI <sup>†</sup>	18.8, 41.9	35.0, 48.7	0.1, 21.7
p-value <sup>‡</sup>	0.003	< 0.001	
<b>Response rate</b>			

Responders, n (%)	28.2	40	15.1
95% CI <sup>§</sup>	20.3, 37.3	31.5, 49.0	9.2, 22.8

\* If patient discontinued before starting the Maintenance period, then the Titration period is used.

† 95% CI of the median based on bootstrap percentiles.

‡ p-values were for superiority vs. placebo, and obtained from rank ANCOVA with Baseline seizure frequency as covariate, stratified by age subgroup.

§ Exact 95% CI obtained using Clopper-Pearson method.

## 15 REFERENCES

1. OSHA Hazardous Drugs. *OSHA*.  
<http://www.osha.gov/SLTC/hazardousdrugs/index.html>.

## 16 HOW SUPPLIED/STORAGE AND HANDLING

Everolimus Tablets for Oral Suspension are available containing 2 mg, 3 mg, or 5 mg of everolimus.

The 2 mg tablets are white to slightly yellow, round, unscored tablets debossed with **M** on one side of the tablet and **EVD** over **2** on the other side. They are available as follows:

NDC 0378-0005-85  
cartons of 28 tablets

The 3 mg tablets are white to slightly yellow, round, unscored tablets debossed with **M** on one side of the tablet and **EVD** over **3** on the other side. They are available as follows:

NDC 0378-0006-85  
cartons of 28 tablets

The 5 mg tablets are white to slightly yellow, round, unscored tablets debossed with **M** on one side of the tablet and **EVD** over **5** on the other side. They are available as follows:

NDC 0378-0007-85  
cartons of 28 tablets

**Store at 20° to 25°C (68° to 77°F). [See USP Controlled Room Temperature.]**

**Store in the original container, protect from light and moisture.**

Follow special handling and disposal procedures for anti-cancer pharmaceuticals.<sup>1</sup>

## 17 PATIENT COUNSELING INFORMATION

Advise the patient to read the FDA-approved patient labeling (Patient Information and Instructions for Use).

**Non-infectious Pneumonitis:** Advise patients of the risk of developing non-infectious pneumonitis and to immediately report any new or worsening respiratory symptoms to their healthcare provider [see *Warnings and Precautions (5.1)*].

**Infections:** Advise patients that they are more susceptible to infections and that they should immediately report any signs or symptoms of infections to their healthcare provider [see *Warnings and Precautions (5.2)*].

**Hypersensitivity Reactions:** Advise patients of the risk of clinically significant hypersensitivity reactions and to promptly contact their healthcare provider or seek emergency care for signs of hypersensitivity reaction, including rash, itching, hives, difficulty breathing or swallowing, flushing, chest pain, or dizziness [see *Contraindications (4), Warnings and Precautions (5.3)*].

**Angioedema with Concomitant Use of ACE Inhibitors:** Advise patients to avoid ACE inhibitors and to promptly contact their healthcare provider or seek emergency care for signs or symptoms of angioedema [see *Warnings and Precautions (5.4)*].

**Stomatitis:** Advise patients of the risk of stomatitis and to use alcohol-free mouthwashes during treatment [see *Warnings and Precautions (5.5)*].

**Renal Impairment:** Advise patients of the risk of developing kidney failure and the need to monitor their kidney function periodically during treatment [see *Warnings and Precautions (5.6)*].

**Risk of Impaired Wound Healing:** Advise patients that everolimus tablets for oral suspension may impair wound healing. Advise patients to inform their healthcare provider of any planned surgical procedure [see *Warnings and Precautions (5.7)*].

**Metabolic Disorders:** Advise patients of the risk of metabolic disorders and the need to monitor glucose and lipids periodically during therapy [see *Warnings and Precautions (5.9)*].

**Myelosuppression:** Advise patients of the risk of myelosuppression and the need to monitor CBCs periodically during therapy [see *Warnings and Precautions (5.10)*].

**Risk of Infection or Reduced Immune Response With Vaccination:** Advise patients to avoid the use of live vaccines and close contact with those who have received live vaccines [see *Warnings and Precautions (5.11)*].

**Embryo-Fetal Toxicity:** Advise females of reproductive potential of the potential risk to a fetus. Advise females of reproductive potential to use effective contraception during treatment and for 8 weeks after the last dose. Advise patients to inform their healthcare provider of a known or suspected pregnancy. Advise males with female partners of reproductive potential to use effective contraception during treatment and for 4 weeks after the last dose [see *Warnings and Precautions (5.13), Use in Specific Populations (8.1, 8.3)*].

**Radiation Sensitization and Radiation Recall:** Radiation sensitization and recall can occur in patients treated with radiation prior to, during, or subsequent to everolimus tablets for oral suspension treatment. Advise patients to inform their healthcare provider if they have had or are planning to receive radiation therapy [see *Warnings and Precautions (5.12)*].

**Lactation:** Advise women not to breastfeed during treatment with everolimus tablets for oral suspension and for 2 weeks after the last dose [see *Use in Specific Populations (8.2)*].

**Infertility:** Advise males and females of reproductive potential of the potential risk for impaired fertility [see *Use in Specific Populations (8.3)*].

The brands listed are trademarks of their respective owners.

## Patient Information

### **Everolimus Tablets for Oral Suspension (e" ver oh' li mus)**

Read this Patient Information leaflet that comes with everolimus tablets for oral suspension before you start taking it and each time you get a refill. There may be new information. This information does not take the place of talking to your healthcare provider about your medical condition or treatment.

### **What is the most important information I should know about everolimus tablets for oral suspension?**

#### **Everolimus tablets for oral suspension can cause serious side effects, including:**

**1. You may develop lung or breathing problems.** In some people lung or breathing problems may be severe and can lead to death. Tell your healthcare provider right away if you have any of these symptoms:

- New or worsening cough
- Shortness of breath
- Chest pain
- Difficulty breathing or wheezing

**2. You may be more likely to develop an infection,** such as pneumonia, or a bacterial, fungal or viral infection. Viral infections may include active hepatitis B in people who have had hepatitis B in the past (reactivation). In some people (including adults and children) these infections may be severe and can lead to death. You may need to be treated as soon as possible.

Tell your healthcare provider right away if you have a temperature of 100.5°F or above, chills, or do not feel well.

Symptoms of hepatitis B or infection may include the following:

- Fever
- Chills
- Skin rash
- Joint pain and swelling
- Tiredness
- Loss of appetite
- Nausea
- Pale stools or dark urine
- Yellowing of the skin
- Pain in the upper right side of the stomach

**3. Severe allergic reactions.** Call your healthcare provider or get medical help right away if you get signs and symptoms of a severe allergic reaction, including: rash, itching, hives, flushing, trouble breathing or swallowing, chest pain or dizziness.

**4. Possible increased risk for a type of allergic reaction called angioedema,** in people who take an Angiotensin-Converting Enzyme (ACE) inhibitor medicine during treatment with everolimus tablets for oral suspension. Talk with your healthcare provider before taking everolimus tablets for oral suspension

if you are not sure if you take an ACE inhibitor medicine. Get medical help right away if you have trouble breathing or develop swelling of your tongue, mouth, or throat during treatment with everolimus tablets for oral suspension.

**5. Mouth ulcers and sores.** Mouth ulcers and sores are common during treatment with everolimus tablets for oral suspension but can also be severe. When you start treatment with everolimus tablets for oral suspension, your healthcare provider may tell you to also start a prescription mouthwash to reduce the likelihood of getting mouth ulcers or sores and to reduce their severity. Follow your healthcare provider's instructions on how to use this prescription mouthwash. If you develop pain, discomfort, or open sores in your mouth, tell your healthcare provider. Your healthcare provider may tell you to restart this mouthwash or to use a special mouthwash or mouth gel that does not contain alcohol, peroxide, iodine, or thyme.

**6. You may develop kidney failure.** In some people this may be severe and can lead to death. Your healthcare provider should do tests to check your kidney function before and during your treatment with everolimus tablets for oral suspension.

If you have any of the serious side effects listed above, you may need to stop taking everolimus tablets for oral suspension for a while or use a lower dose. Follow your healthcare provider's instructions.

### **What are everolimus tablets for oral suspension?**

Everolimus tablets for oral suspension are a prescription medicine used to treat:

- adults and children 1 year of age and older with a genetic condition called tuberous sclerosis complex (TSC) who have a brain tumor called subependymal giant cell astrocytoma (SEGA) when the tumor cannot be removed completely by surgery.
- adults and children 2 years of age and older with a genetic condition called tuberous sclerosis complex (TSC) who have certain types of seizures (epilepsy), as an added treatment to other antiepileptic medicines.

**Do not take everolimus tablets for oral suspension** if you have had a severe allergic reaction to everolimus.

Talk to your healthcare provider before taking this medicine if you are allergic to:

- a medicine that contains sirolimus
- a medicine that contains temsirolimus

Ask your healthcare provider if you do not know.

**Before taking everolimus tablets for oral suspension, tell your healthcare provider about all of your medical conditions, including if you:**

- Have or have had kidney problems
- Have or have had liver problems
- Have diabetes or high blood sugar
- Have high blood cholesterol levels
- Have any infections
- Previously had hepatitis B
- Are scheduled to receive any vaccinations. You should not receive a "live vaccine" or be around people who have recently received a "live vaccine" during your



treatment with everolimus tablets for oral suspension. If you are not sure about the type of immunization or vaccine, ask your healthcare provider. For children with TSC and SEGA or certain types of seizures, work with your healthcare provider to complete the recommended childhood series of vaccines before your child starts treatment with everolimus tablets for oral suspension.

- Are pregnant, can become pregnant, or have a partner who can become pregnant. Everolimus tablets for oral suspension can cause harm to your unborn baby.

**Females who are able to become pregnant:**

- o Your healthcare provider will give you a pregnancy test before you start treatment with everolimus tablets for oral suspension.
- o You should use effective birth control during treatment and for 8 weeks after your last dose of everolimus tablets for oral suspension.

**Males** with a female partner, you should use effective birth control during treatment and for 4 weeks after your last dose of everolimus tablets for oral suspension.

Talk to your healthcare provider about birth control methods that may be right for you during this time. If you become pregnant or think you are pregnant, tell your healthcare provider right away.

- Are breastfeeding or plan to breastfeed. It is not known if everolimus passes into your breast milk. Do not breastfeed during treatment and for 2 weeks after your last dose of everolimus tablets for oral suspension.
- Are planning to have surgery or if you have had a recent surgery. You should stop taking everolimus tablets for oral suspension at least 1 week before planned surgery. See **“What are the possible side effects of everolimus tablets for oral suspension?”**
- Have received radiation therapy or are planning to receive radiation therapy in the future. See **“What are the possible side effects of everolimus tablets for oral suspension?”**

**Tell your healthcare provider about all of the medicines you take**, including prescription and over-the-counter medicines, vitamins, and herbal supplements.

Everolimus tablets for oral suspension may affect the way other medicines work, and other medicines can affect how everolimus tablets for oral suspension work. Taking everolimus tablets for oral suspension with other medicines can cause serious side effects.

Know the medicines you take. Keep a list of them and show it to your healthcare provider and pharmacist when you get a new medicine. Especially tell your healthcare provider if you take:

- St. John’s Wort (*Hypericum perforatum*)
- Medicine for:
  - o Fungal infections
  - o Bacterial infections
  - o Tuberculosis
  - o Seizures

- o HIV-AIDS
- o Heart conditions or high blood pressure
- Medicines that weaken your immune system (your body's ability to fight infections and other problems)

Ask your healthcare provider or pharmacist if you are not sure if your medicine is one of those taken for the conditions listed above. If you are taking any medicines for the conditions listed above, your healthcare provider might need to prescribe a different medicine or your dose of everolimus tablets for oral suspension may need to be changed. You should also tell your healthcare provider before you start taking any new medicine.

### **How should I take everolimus tablets for oral suspension?**

- Your healthcare provider will prescribe the dose of everolimus tablets for oral suspension that is right for you.
- Take everolimus tablets for oral suspension exactly as your healthcare provider tells you to.
- Your healthcare provider may change your dose of everolimus tablets for oral suspension or tell you to temporarily interrupt dosing, if needed.
- **Take only AFINITOR® or everolimus tablets for oral suspension. Do not mix AFINITOR and everolimus tablets for oral suspension together.**
- Use scissors to open the blister pack.
- Take everolimus tablets for oral suspension 1 time each day at about the same time.
- Take everolimus tablets for oral suspension the same way each time, either with food or without food.
- If you take too many everolimus tablets for oral suspension, contact your healthcare provider or go to the nearest hospital emergency room right away. Take the pack of everolimus tablets for oral suspension with you.
- If you miss a dose of everolimus tablets for oral suspension, you may take it if it is **less than 6 hours** after the time you normally take it. If it is **more than 6 hours** after you normally take your everolimus tablets for oral suspension, skip the dose for that day. The next day, take everolimus tablets for oral suspension at your usual time. Do not take 2 doses to make up for a missed dose. If you are not sure about what to do, call your healthcare provider.
- You should have blood tests before you start everolimus tablets for oral suspension and as needed during your treatment. These will include tests to check your blood cell count, kidney and liver function, cholesterol, and blood sugar levels.
- If you take everolimus tablets for oral suspension to treat SEGA or certain types of seizures with TSC, you will also need to have blood tests regularly to measure how much medicine is in your blood. This will help your healthcare provider decide how many everolimus tablets for oral suspension you need to take.

### **Everolimus tablets for oral suspension:**

- If your healthcare provider prescribes everolimus tablets for oral suspension for you, see the "Instructions for Use" that comes with your medicine for instructions on how to prepare and take your dose.
- Each dose of everolimus tablets for oral suspension must be prepared as a suspension before it is given.

- Everolimus tablets for oral suspension can cause harm to an unborn baby. When possible, the suspension should be prepared by an adult who is not pregnant or planning to become pregnant.
- Wear gloves to avoid possible contact with everolimus when preparing suspensions of everolimus tablets for oral suspension for another person.

### **What should I avoid while taking everolimus tablets for oral suspension?**

You should not drink grapefruit juice or eat grapefruit during your treatment with everolimus tablets for oral suspension. It may make the amount of everolimus in your blood increase to a harmful level.

### **What are the possible side effects of everolimus tablets for oral suspension? Everolimus tablets for oral suspension can cause serious side effects, including:**

- **See “What is the most important information I should know about everolimus tablets for oral suspension?” for more information.**
- **Risk of wound healing problems.** Wounds may not heal properly during everolimus tablets for oral suspension treatment. Tell your healthcare provider if you plan to have any surgery before starting or during treatment with everolimus tablets for oral suspension.
  - You should stop taking everolimus tablets for oral suspension at least 1 week before planned surgery.
  - Your healthcare provider should tell you when you may start taking everolimus tablets for oral suspension again after surgery.
- **Increased blood sugar and fat (cholesterol and triglyceride) levels in the blood.** Your healthcare provider should do blood tests to check your fasting blood sugar, cholesterol, and triglyceride levels in the blood before you start and during treatment with everolimus tablets for oral suspension.
- **Decreased blood cell counts.** Everolimus tablets for oral suspension can cause you to have decreased red blood cells, white blood cells, and platelets. Your healthcare provider should do blood tests to check your blood cell counts before you start and during treatment with everolimus tablets for oral suspension.
- **Worsening side effects from radiation treatment,** that can sometimes be severe. Tell your healthcare provider if you have had or are planning to receive radiation therapy.

**The most common side effects of everolimus tablets for oral suspension in people who have SEGA or certain types of seizures with TSC include** respiratory tract infections.

### **Other side effects that may occur with everolimus tablets for oral suspension:**

- Absence of menstrual periods (menstruation). You may miss 1 or more menstrual periods. Tell your healthcare provider if this happens.
- Everolimus tablets for oral suspension may affect fertility in females and may affect your ability to become pregnant. Talk to your healthcare provider if this is a concern for you.
- Everolimus tablets for oral suspension may affect fertility in males and may affect

your ability to father a child. Talk to your healthcare provider if this is a concern for you.

Tell your healthcare provider if you have any side effect that bothers you or does not go away.

These are not all the possible side effects of everolimus tablets for oral suspension. For more information, ask your healthcare provider or pharmacist.

**Call your doctor for medical advice about side effects. You may report side effects to FDA at 1-800-FDA-1088.**

#### **How should I store everolimus tablets for oral suspension?**

- Store everolimus tablets for oral suspension at room temperature, between 20° to 25°C (68° to 77°F).
- Keep everolimus tablets for oral suspension in the pack they come in.
- Open the blister pack just before taking everolimus tablets for oral suspension.
- Keep everolimus tablets for oral suspension dry and away from light.
- Do not use everolimus tablets for oral suspension that are out of date or no longer needed.

**Keep everolimus tablets for oral suspension and all medicines out of the reach of children.**

#### **General information about the safe and effective use of everolimus tablets for oral suspension**

Medicines are sometimes prescribed for purposes other than those listed in a Patient Information leaflet. Do not use everolimus tablets for oral suspension for a condition for which they were not prescribed. Do not give everolimus tablets for oral suspension to other people, even if they have the same problem you have. They may harm them. This leaflet summarizes the most important information about everolimus tablets for oral suspension. If you would like more information, talk with your healthcare provider. You can ask your healthcare provider or pharmacist for information written for healthcare professionals.

#### **What are the ingredients in everolimus tablets for oral suspension?**

Active ingredient: everolimus.

Inactive ingredients: anhydrous lactose, butylated hydroxytoluene, croscarmellose sodium, crospovidone, hypromellose, lactose monohydrate, magnesium stearate, mannitol, microcrystalline cellulose and silicon dioxide.

Manufactured for: Mylan Pharmaceuticals Inc., Morgantown, WV 26505 U.S.A.

The brands listed are trademarks of their respective owners.

For more information, call Mylan at 1-877-446-3679 (1-877-4-INFO-RX).

This Patient Information has been approved by the U.S. Food and Drug Administration.

## **Instructions for Use Everolimus Tablets for Oral Suspension (e" ver oh' li mus)**

Read these Instructions for Use for everolimus tablets for oral suspension before you start taking it and each time you get a refill. There may be new information. This information does not take the place of talking to your healthcare provider about your medical condition or treatment.

### **Important Information:**

- **Take everolimus tablets for oral suspension as a suspension only.** Everolimus tablets for oral suspension are prepared as a suspension of undissolved medicine that is mixed with water, and then it is taken by mouth. Do not chew, crush, or swallow everolimus tablets for oral suspension whole.
- **Everolimus tablets for oral suspension can cause harm to an unborn baby.** When possible, the suspension should be prepared by an adult who is not pregnant or planning to become pregnant.
- Keep everolimus tablets for oral suspension and the prepared suspension out of the reach of children.
- Anyone who prepares suspensions of everolimus tablets for oral suspension for another person should wear gloves to avoid possible contact with the drug.
- Only use water with everolimus tablets for oral suspension to prepare the suspension. Do not prepare the suspension with juice or any other liquids.
- The suspension must be given right away. If you do not give the dose within 60 minutes after it has been prepared, throw away the dose and prepare a new dose of everolimus tablets for oral suspension.
- Before starting to prepare the suspension, collect all of the supplies that you will need to prepare and take the suspension. Do not use any of these supplies for purposes other than preparing and taking the everolimus tablets for oral suspension.

### **Supplies needed to prepare the suspension in an oral syringe:**

- Blister card with everolimus tablets for oral suspension
- Scissors to open the blister card
- Disposable gloves (for one time use)
- 2 clean drinking glasses
- Approximately 30 mL of water
- 10 mL oral syringe (for one time use) (see Figure A)
- Paper towels

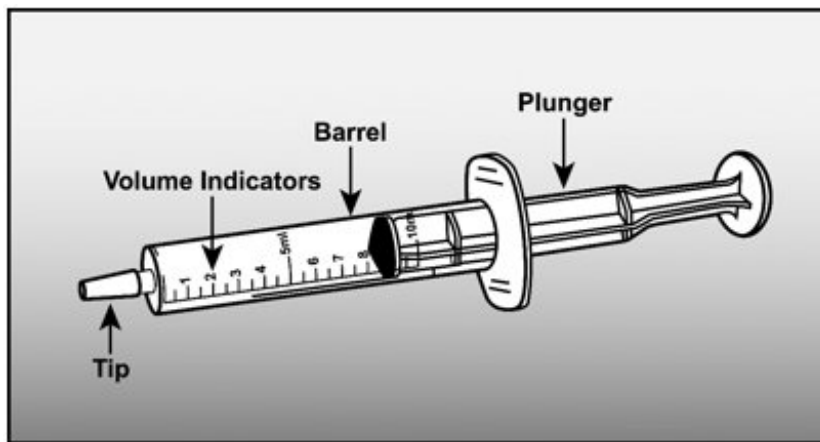

**Figure A**

**Supplies needed to prepare the suspension in a small drinking glass:**

- Blister card with everolimus tablets for oral suspension
- Scissors to open the blister card
- Disposable gloves (for one time use)
- 30 mL dose cup for measuring water (you can ask your pharmacist for this)
- 1 clean drinking glass (maximum size 100 mL)
- Water to prepare the suspension
- Spoon for stirring
- Paper towels

**Preparing a dose of everolimus tablets for oral suspension using an oral syringe:**

**Step 1:** Prepare a clean, flat work surface that is away from where you prepare and eat food. Place a clean paper towel on the work surface. Place the needed supplies on the paper towel.

**Step 2:** Wash and dry your hands well before preparing the medicine (see Figure B).

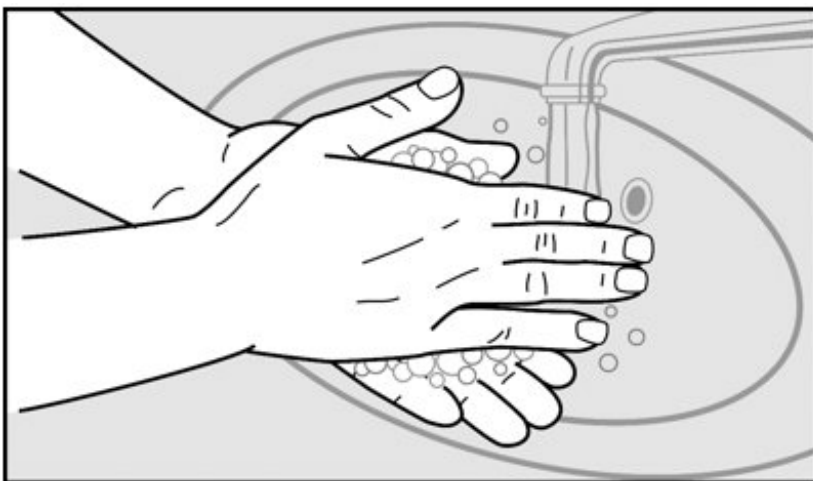

**Figure B**

**Step 3:** If preparing the everolimus tablets for oral suspension for another person, put

on disposable gloves (see Figure C).

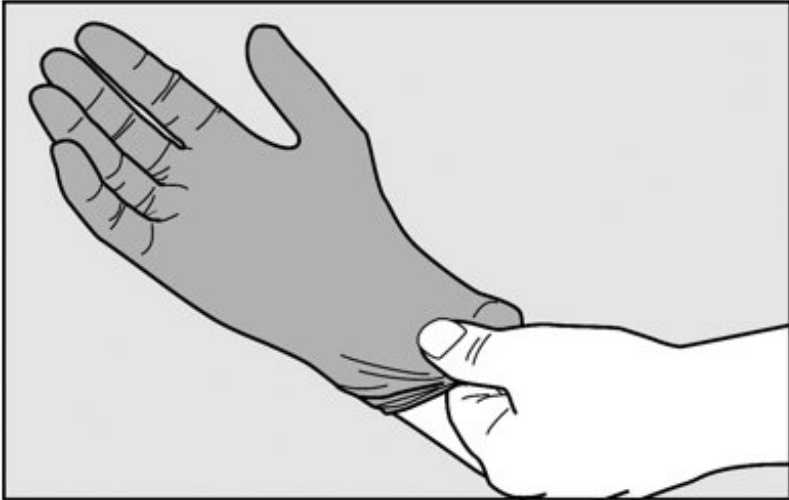

**Figure C**

**Step 4:** Take a 10 mL oral syringe and pull back on the plunger. Remove the plunger from the barrel of the syringe (see Figure D).

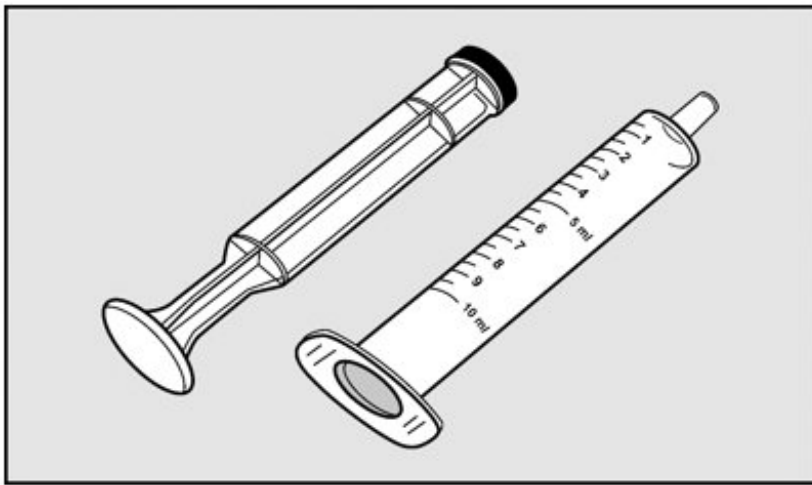

**Figure D**

**Step 5:** Use scissors to open the blister card along the dotted line (see Figure E) and remove the prescribed number of everolimus tablets for oral suspension from the blister card. Place them into the barrel of the oral syringe (see Figure F).

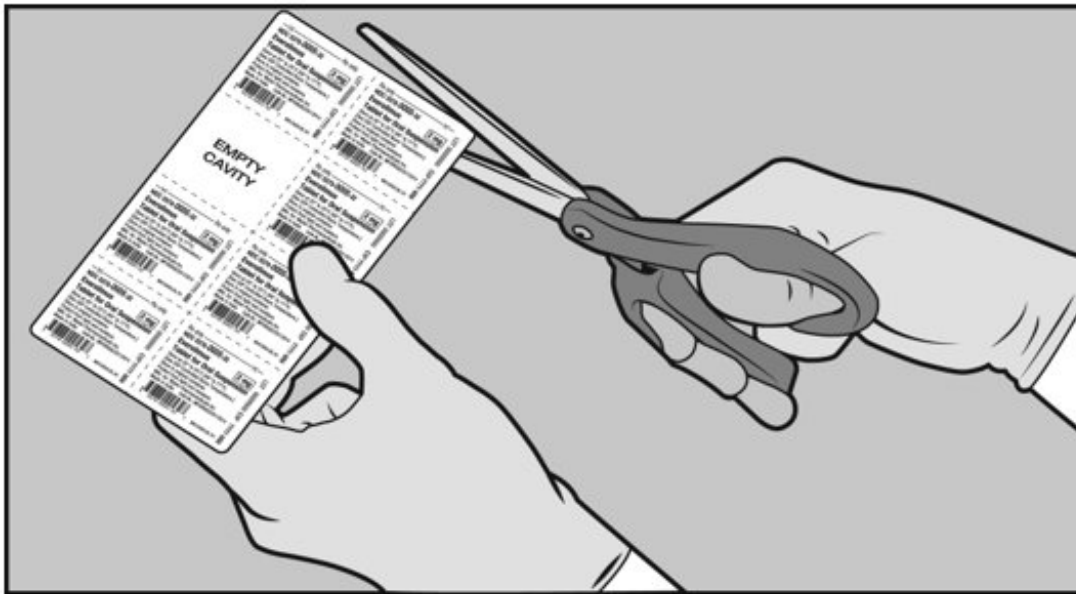

Figure E

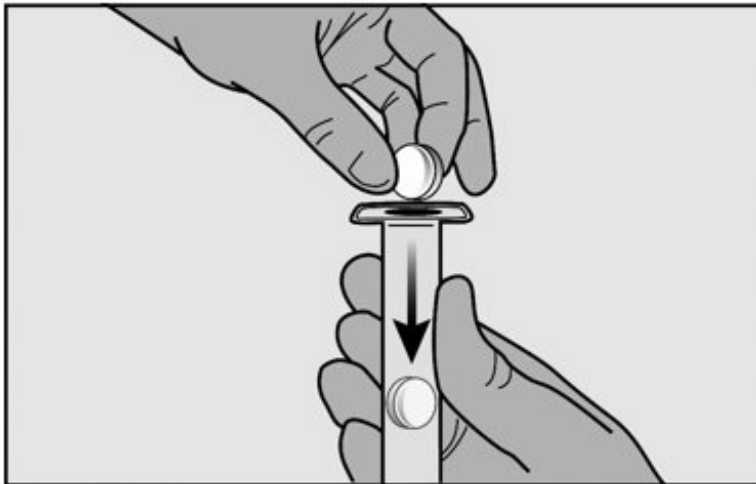

Figure F

- Doses of up to 10 mg can be prepared with the oral syringe. **If your total prescribed dose is more than 10 mg, you will need to split the dose. Follow steps 4 through 17 for the first half of the dose. Then repeat steps 4 through 17 for the second half of the dose. Do not prepare a dose of more than 10 mg in one syringe.** Ask your pharmacist or healthcare provider if you are not sure what to do.

**Step 6:** Re-insert the plunger into the barrel of the oral syringe (see Figure G) and push the plunger in until it comes into contact with the everolimus tablets for oral suspension (see Figure H).



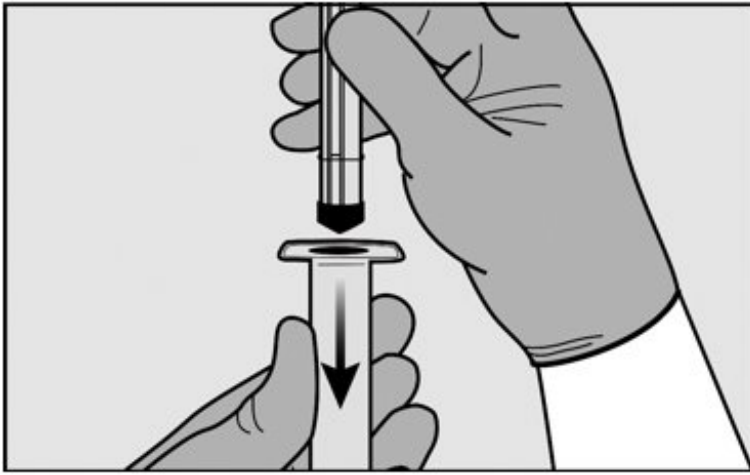

Figure G

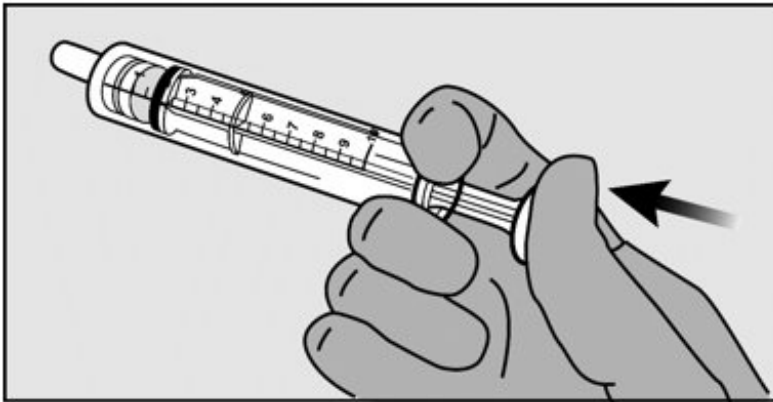

Figure H

**Step 7:** Fill a small drinking glass with about 30 mL of water. Insert the tip of the oral syringe into the water. Then slowly pull back on the plunger until the syringe is about half full of water and all the tablets are covered by water (see Figure I).

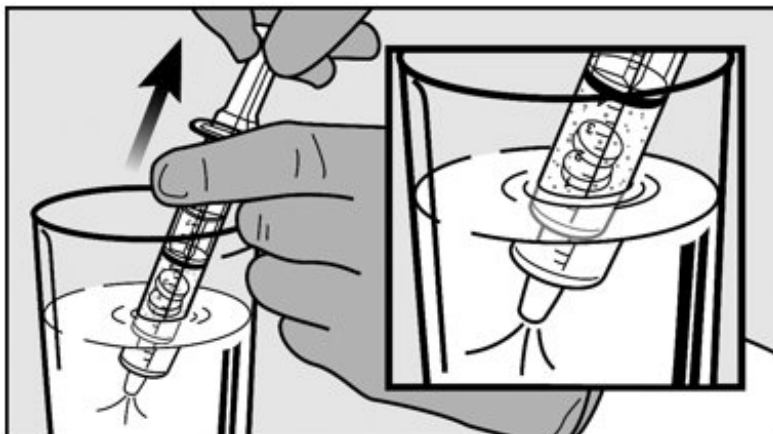
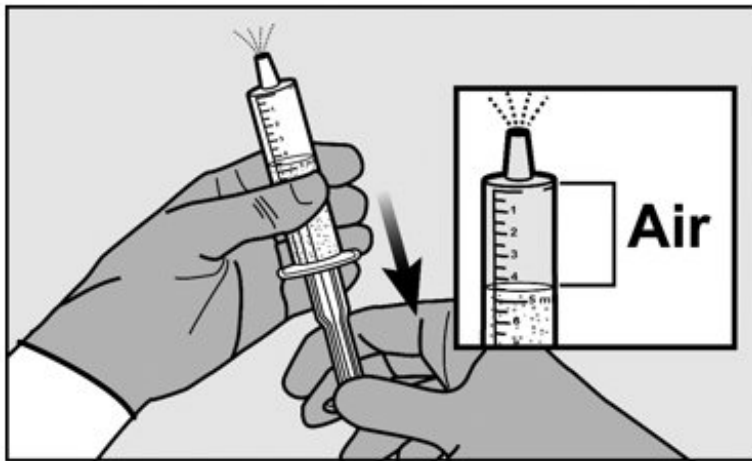

Figure I

**Step 8:** Hold the oral syringe with the tip pointing up. Pull back on the plunger to draw back about 4 mL of air (see Figure J).



**Figure J**

**Step 9:** Place the filled oral syringe in the clean, empty glass with the tip pointing up. Wait **3 minutes** to allow everolimus tablets for oral suspension to break apart (see Figure K).

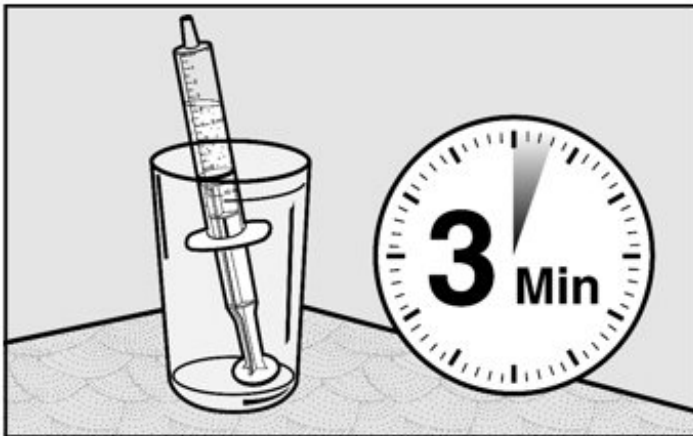

**Figure K**

**Step 10:** Slowly turn the oral syringe up and down five times just before giving the dose (see Figure L). **Do not shake** the syringe.

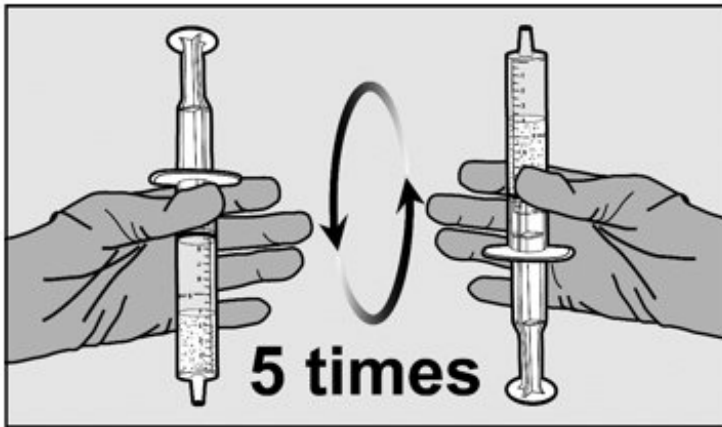

**Figure L**

**Step 11:** Hold the oral syringe in an upright position (with the tip up). Carefully remove most of the air by pushing up gently on the plunger (see Figure M).

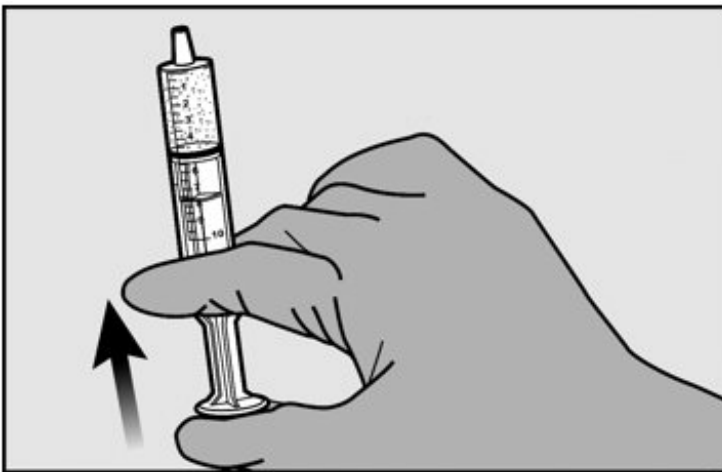

**Figure M**

**Step 12:** Give the full contents of the oral syringe slowly and gently into the mouth right away, within 60 minutes of preparing it (see Figure N). Carefully remove the syringe from the mouth. Continue with steps 13 through 17 to make sure that the entire dose of medicine is given.



**Figure N**

**Step 13:** Insert the tip of the oral syringe into the drinking glass that is filled with water, and pull up about 5 mL of water by slowly pulling back on the plunger (see Figure O).

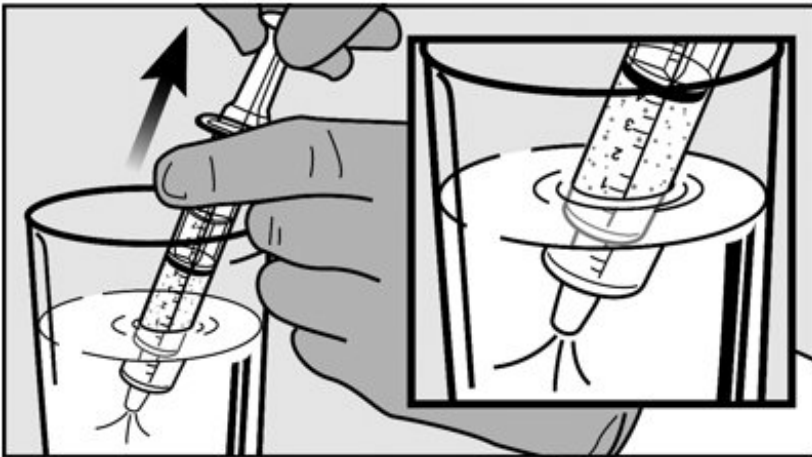

**Figure O**

**Step 14:** Hold the oral syringe with the tip pointing up and use the plunger to draw back about 4 mL of air (see Figure P).

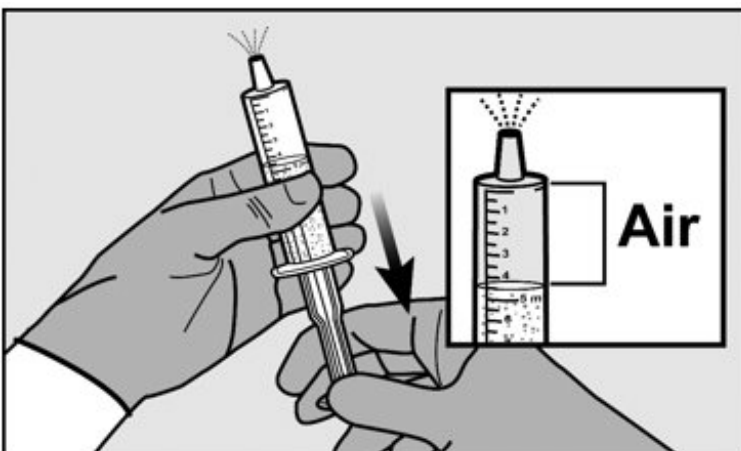

**Figure P**

**Step 15:** With the tip of the syringe still pointing up, swirl the contents by gently rotating the syringe in a circular motion (see Figure Q).



**Figure Q**

**Step 16:** Hold the oral syringe in an upright position (with the tip up). Carefully remove most of the air by pushing up gently on the plunger (see Figure R).



**Figure R**

**Step 17:** Give the full contents of the oral syringe slowly and gently into the mouth by pushing on the plunger (see Figure S). Carefully remove the syringe from the mouth.



**Figure S**

**If the total prescribed dose is more than 10 mg, repeat steps 4 through 17 to finish giving the dose.**

**Step 18:** Throw away the oral syringe, paper towel, and used gloves in your household trash.

**Step 19:** Wash your hands.

**Preparing a dose of everolimus tablets for oral suspension using a small drinking glass:**

**Step 1:** Prepare a clean, flat work surface that is away from where you prepare and eat food. Place a clean paper towel on the work surface. Place the needed supplies on the paper towel.

**Step 2:** Wash and dry your hands before preparing the medicine (see Figure T).

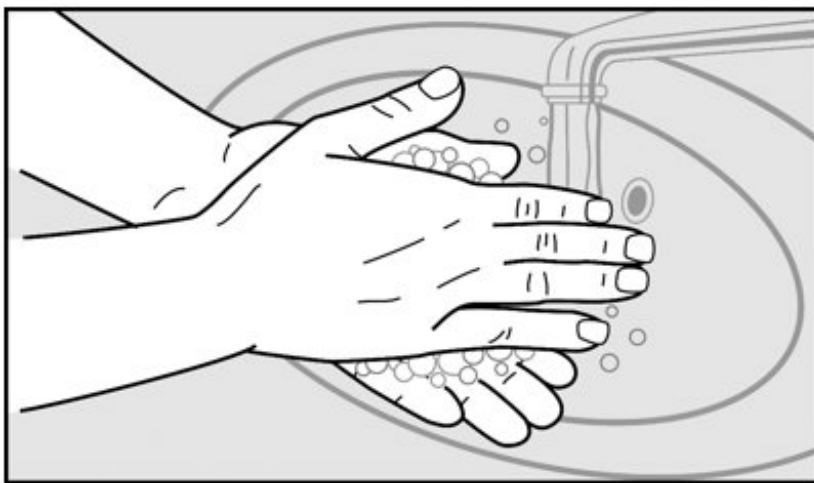

**Figure T**

**Step 3:** If preparing the everolimus tablets for oral suspension for another person, put on disposable gloves (see Figure U).

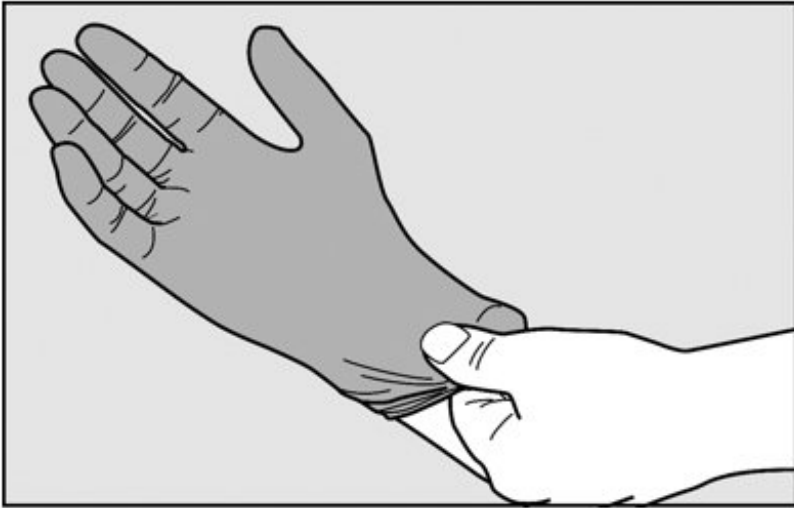

**Figure U**

**Step 4:** Add about 25 mL of water to the 30 mL dose cup. The amount of water added does not need to be exact (see Figure V).

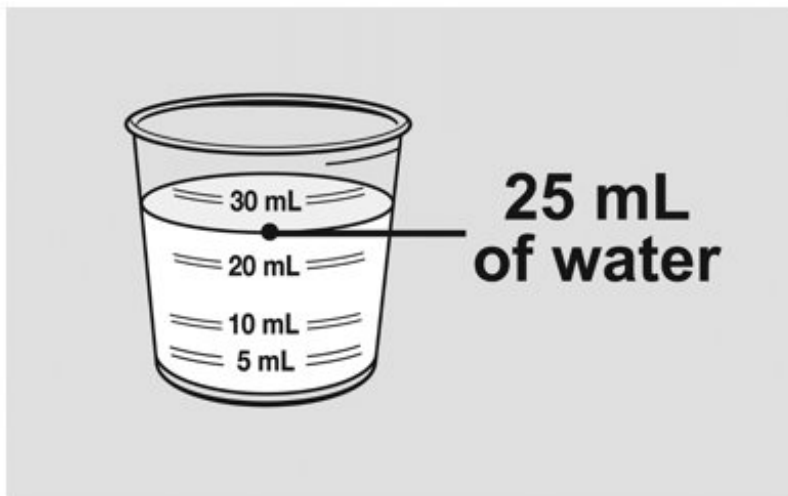

**Figure V**

**Step 5:** Pour the water from the dose cup into a small drinking glass (maximum size 100 mL) (see Figure W).



**Figure W**

- Doses up to 10 mg can be prepared in the small drinking glass. If your total prescribed dose is more than 10 mg you will need to split the dose. **Follow steps 4 through 10 for the first half of the dose. Then repeat steps 4 through 10 for the second half of the dose.** Ask your pharmacist or healthcare provider if you are not sure what to do.

**Step 6:** Use scissors to open the blister card along the dotted line (see Figure X) and remove the prescribed number of everolimus tablets for oral suspension from the blister card.

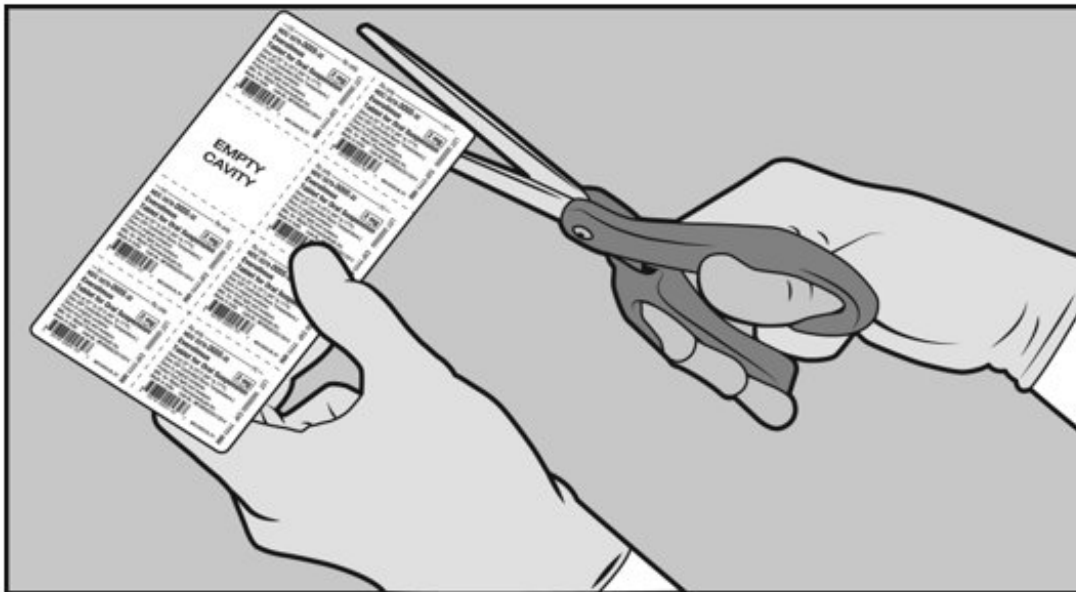

**Figure X**

**Step 7:** Add the prescribed number of everolimus tablets for oral suspension into the water (see Figure Y).



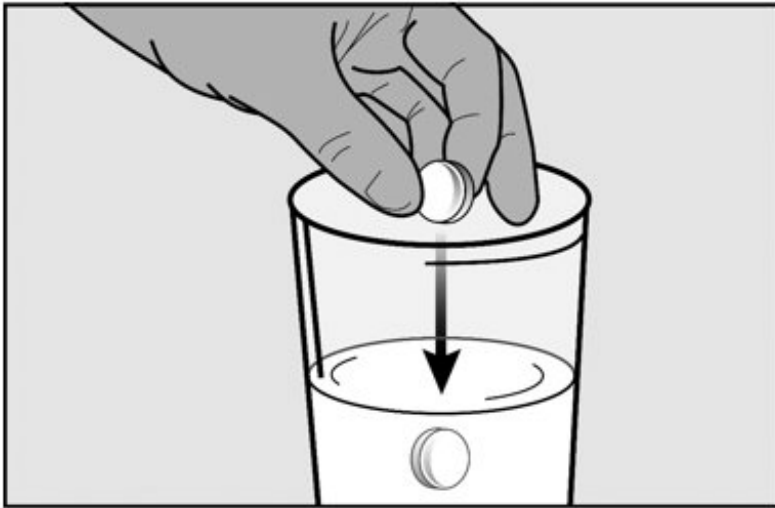

**Figure Y**

**Step 8:** Wait **3 minutes** to allow everolimus tablets for oral suspension to break apart (see Figure Z).

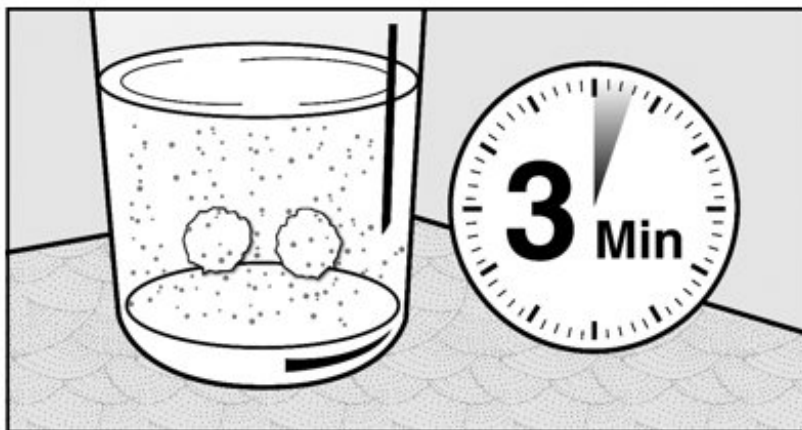

**Figure Z**

**Step 9:** Gently stir the contents of the glass with a spoon and place the spoon back on the paper towel (see Figure AA). Drink the full amount of the suspension right away, within 60 minutes of preparing it (see Figure BB).

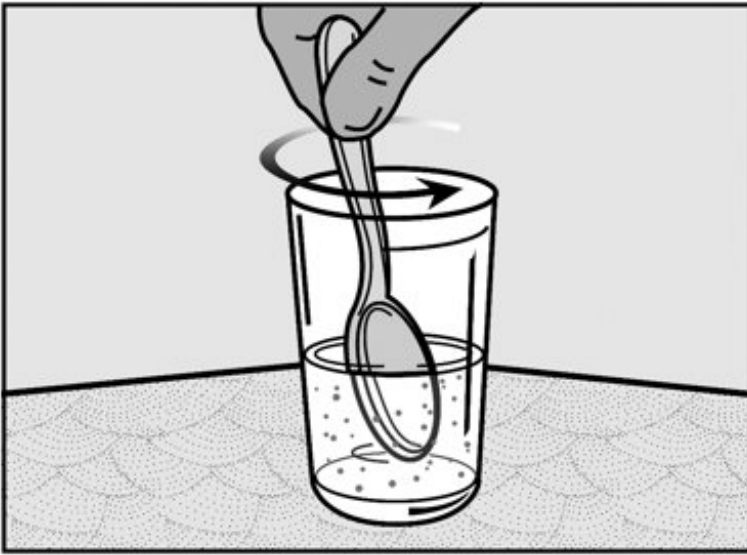

**Figure AA**



**Figure BB**

**Step 10:** Refill the glass with the same amount of water (about 25 mL). Stir the contents with the same spoon and place the spoon back on the paper towel (see Figure CC). Drink the full amount right away so that you take any remaining medicine (see Figure DD).

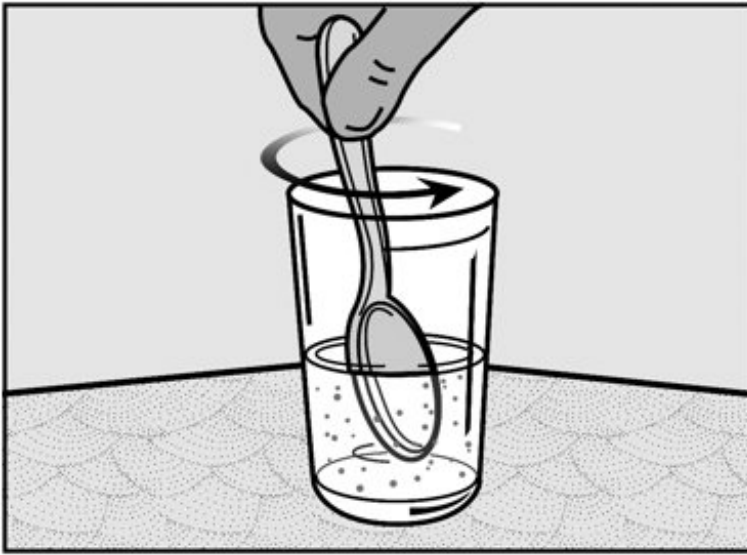

Figure CC

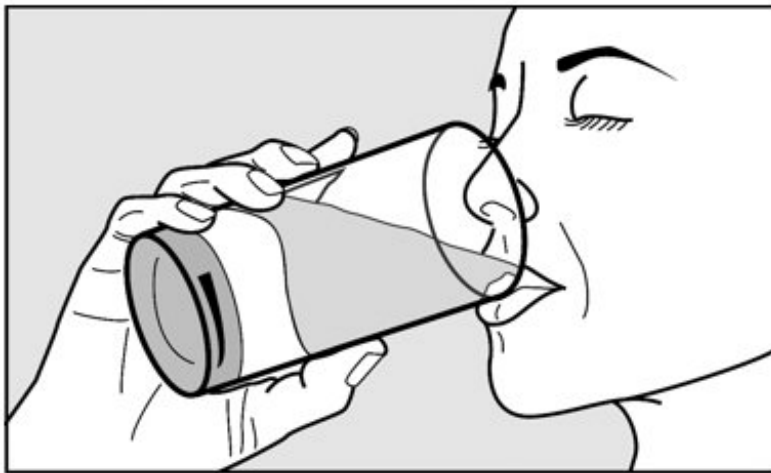
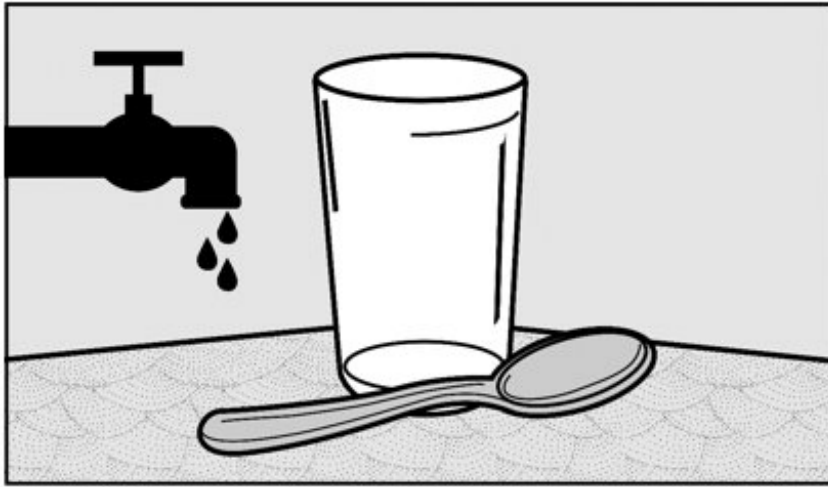

Figure DD

**If your total prescribed dose is more than 10 mg, repeat steps 4 through 10 to finish taking your dose.**

**Step 11:** Wash the glass and the spoon thoroughly with water. Wipe the glass and spoon with a clean paper towel and store them in a dry and clean place until your next dose of everolimus tablets for oral suspension (see Figure EE).



**Figure EE**

**Step 12:** Throw away the used paper towel and gloves in your household trash.

**Step 13:** Wash your hands.

**How should I store everolimus tablets for oral suspension?**

- Store everolimus tablets for oral suspension at room temperature, between 20° to 25°C (68° to 77°F).
- Keep everolimus tablets for oral suspension in the pack they come in.
- Open the blister pack just before taking everolimus tablets for oral suspension.
- Keep everolimus tablets for oral suspension dry and away from light.
- Do not use everolimus tablets for oral suspension that are out of date or no longer needed.

**Keep everolimus tablets for oral suspension and all medicines out of the reach of children.**

This Instructions for Use has been approved by the U.S. Food and Drug Administration.

Manufactured for:

**Mylan Pharmaceuticals Inc.**  
Morgantown, WV 26505 U.S.A.

Manufactured by:

**Mylan Laboratories Limited**  
Hyderabad – 500 096, India

75097369

Revised: 5/2023  
MXI:EVERTOS:R1

**PRINCIPAL DISPLAY PANEL - 2 mg**

**NDC 0378-0005-85**

**Everolimus  
Tablets for Oral Suspension**

**2 mg**

**TABLETS MUST BE DISPERSED IN WATER.**

**TABLETS MUST NOT BE SWALLOWED WHOLE, CHEWED, OR CRUSHED.**

**Each tablet contains everolimus, 2 mg**

**Rx only**

**28 Tablets for Oral Suspension (carton contains 4 individual blister cards of 7 tablets)**

**For oral use.**

**Usual Dosage:** See accompanying prescribing information.

See enclosed everolimus tablets for oral suspension Instructions for Use.

**Store at 20° to 25°C (68° to 77°F).**

**[See USP Controlled Room Temperature.]**

**Store in the original container; protect from light and moisture.**

**Keep this and all medication out of the reach of children.**

Manufactured for:

**Mylan Pharmaceuticals Inc.**

Morgantown, WV 26505 U.S.A.

Made in India

Code No. MP/DRUGS/25/1/2014

**MXI:0005:28C:R1**

**Mylan.com**

Prompt "LOT" & "EXP" will be printed along with Variable Data online Coding (see e.g. below)

LOT 1234567  
 EXP YYYY-MM  
 \*SN 000000000  
 \*GTIN 00000000000000  
 \*(wherever is applicable)



NDC 0378-0005-85

# Everolimus

## Tablets for Oral Suspension

**2 mg**



TABLETS MUST BE DISPERSED IN WATER.  
 TABLETS MUST NOT BE SWALLOWED WHOLE, CHEWED OR CRUSHED.

Each tablet contains everolimus, 2 mg



Rx only 28 Tablets for Oral Suspension (carton contains 4 individual blister cards of 7 tablets)

NDC 0378-0005-85

# Everolimus

## Tablets for Oral Suspension

**2 mg**



Each tablet contains everolimus, 2 mg



NDC 0378-0005-85

# Everolimus

## Tablets for Oral Suspension

**2 mg**



TABLETS MUST BE DISPERSED IN WATER.  
 TABLETS MUST NOT BE SWALLOWED WHOLE, CHEWED OR CRUSHED.

Each tablet contains everolimus, 2 mg



Rx only 28 Tablets for Oral Suspension (carton contains 4 individual blister cards of 7 tablets)

Manufactured for:  
 Mylan Pharmaceuticals Inc.  
 Morgantown, WV 26505 U.S.A.  
 Made in India  
 Code No. MP/DRUGS/25/12014



MK1000528C:R1  
 Mylan.com

For oral use.  
**Usual Dosage:** See accompanying prescribing information.  
 See enclosed everolimus tablets for oral suspension Instructions for Use.

Store at 20° to 25°C (68° to 77°F).  
 [See USP Controlled Room Temperature.]  
 Store in the original container; protect from light and moisture.  
 Keep this and all medication out of the reach of children.



N 3 0378-0005-85 3

artwork - 100%

**PRINCIPAL DISPLAY PANEL - 3 mg**

**NDC 0378-0006-85**

**Everolimus  
 Tablets for Oral Suspension  
 3 mg**

**TABLETS MUST BE DISPERSED IN WATER.  
 TABLETS MUST NOT BE SWALLOWED WHOLE, CHEWED, OR CRUSHED.  
 Each tablet contains everolimus, 3 mg**

**Rx only**

**28 Tablets for Oral Suspension (carton contains 4 individual blister cards of 7 tablets)**

**For oral use.**

**Usual Dosage:** See accompanying prescribing information.

See enclosed everolimus tablets for oral suspension Instructions for Use.

**Store at 20° to 25°C (68° to 77°F).**

**[See USP Controlled Room Temperature.]**

**Store in the original container; protect from light and moisture.**

**Keep this and all medication out of the reach of children.**

Manufactured for:

**Mylan Pharmaceuticals Inc.**

Morgantown, WV 26505 U.S.A.

Made in India

Code No. MP/DRUGS/25/1/2014

**MXI:0006:28C:R1**

**Mylan.com**

Prompt "LOT" & "EXP" will be printed along with Variable Data online Coding (see e.g. below)

LOT 1234567  
EXP YYYY-MM  
\*SN 0000000000  
\*GTIN 0000000000000  
\*(wherever is applicable)



NDC 0378-0006-85

# Everolimus

## Tablets for Oral Suspension

### 3 mg



TABLETS MUST BE DISPERSED IN WATER.  
TABLETS MUST NOT BE SWALLOWED WHOLE, CHEWED OR CRUSHED.

Each tablet contains everolimus, 3 mg



Rx only 28 Tablets for Oral Suspension (carton contains 4 individual blister cards of 7 tablets)

75097411



NDC 0378-0006-85

# Everolimus

## Tablets for Oral Suspension

### 3 mg



Each tablet contains everolimus, 3 mg



NDC 0378-0006-85

# Everolimus

## Tablets for Oral Suspension

### 3 mg



TABLETS MUST BE DISPERSED IN WATER.  
TABLETS MUST NOT BE SWALLOWED WHOLE, CHEWED OR CRUSHED.

Each tablet contains everolimus, 3 mg



Rx only 28 Tablets for Oral Suspension (carton contains 4 individual blister cards of 7 tablets)

Manufactured for:  
Mylan Pharmaceuticals Inc.  
Morgantown, WV 26505 U.S.A.  
Made in India  
Code No. MP/DRUGS25/1/2014



75097411

For oral use.

Usual Dosage: See accompanying prescribing information.  
See enclosed everolimus tablets for oral suspension Instructions for Use.

Store at 20° to 25°C (68° to 77°F).

[See USP Controlled Room Temperature.]

Store in the original container; protect from light and moisture.

Keep this and all medication out of the reach of children.



N 0378-0006-85 0

artwork - 100%

**PRINCIPAL DISPLAY PANEL - 5 mg**

**NDC 0378-0007-85**

**Everolimus**

**Tablets for Oral Suspension**

**5 mg**

**TABLETS MUST BE DISPERSED IN WATER.**

**TABLETS MUST NOT BE SWALLOWED WHOLE, CHEWED, OR CRUSHED.**

**Each tablet contains everolimus, 5 mg**

**Rx only**



**28 Tablets for Oral Suspension (carton contains 4 individual blister cards of 7 tablets)**

**For oral use.**

**Usual Dosage:** See accompanying prescribing information.

See enclosed everolimus tablets for oral suspension Instructions for Use.

**Store at 20° to 25°C (68° to 77°F).**

**[See USP Controlled Room Temperature.]**

**Store in the original container; protect from light and moisture.**

**Keep this and all medication out of the reach of children.**

Manufactured for:

**Mylan Pharmaceuticals Inc.**

Morgantown, WV 26505 U.S.A.

Made in India

Code No. MP/DRUGS/25/1/2014

**MXI:0007:28C:R1**

**Mylan.com**

Prompt "LOT" & "EXP" will be printed along with Variable Data online Coding (see e.g. below)

LOT 1234567  
 EXP YYYY-MM  
 \*SN 0000000000  
 \*GTIN 00000000000000  
 \*(wherever is applicable)

NDC 0378-0007-85

# Everolimus

Tablets for Oral Suspension

**5 mg**



TABLETS MUST BE DISPERSED IN WATER.  
 TABLETS MUST NOT BE SWALLOWED WHOLE, CHEWED OR CRUSHED.

Each tablet contains everolimus, 5 mg



Rx only 28 Tablets for Oral Suspension (carton contains 4 individual blister cards of 7 tablets)



NDC 0378-0007-85

# Everolimus

Tablets for Oral Suspension

**5 mg**



Each tablet contains everolimus, 5 mg



NDC 0378-0007-85

# Everolimus

Tablets for Oral Suspension

**5 mg**



TABLETS MUST BE DISPERSED IN WATER.  
 TABLETS MUST NOT BE SWALLOWED WHOLE, CHEWED OR CRUSHED.

Each tablet contains everolimus, 5 mg



Rx only 28 Tablets for Oral Suspension (carton contains 4 individual blister cards of 7 tablets)

Manufactured for:  
 Mylan Pharmaceuticals Inc.  
 Morgantown, WV 26505 U.S.A.  
 Made in India  
 Code No. MP/DRUGS/25/12014



For oral use.

Usual Dosage: See accompanying prescribing information.  
 See enclosed everolimus tablets for oral suspension instructions for Use.

Store at 20° to 25°C (68° to 77°F).  
 [See USP Controlled Room Temperature.]  
 Store in the original container; protect from light and moisture.  
 Keep this and all medication out of the reach of children.



artwork - 100%

## EVEROLIMUS

everolimus tablet, for suspension

### Product Information

Product Type	HUMAN PRESCRIPTION DRUG	Item Code (Source)	NDC:0378-0005
Route of Administration	ORAL		

### Active Ingredient/Active Moiety

Ingredient Name	Basis of Strength	Strength
EVEROLIMUS (UNII: 9HW64Q8G6G) (EVEROLIMUS - UNII:9HW64Q8G6G)	EVEROLIMUS	2 mg

## Inactive Ingredients

Ingredient Name	Strength
<b>ANHYDROUS LACTOSE</b> (UNII: 3SY5LH9PMK)	
<b>BUTYLATED HYDROXYTOLUENE</b> (UNII: 1P9D0Z171K)	
<b>CROSCARMELLOSE SODIUM</b> (UNII: M28OL1HH48)	
<b>CROSPVIDONE</b> (UNII: 2S7830E561)	
<b>HYPROMELLOSE 2910 (3 MPA.S)</b> (UNII: 0VUT3PMY82)	
<b>LACTOSE MONOHYDRATE</b> (UNII: EWQ57Q8I5X)	
<b>MAGNESIUM STEARATE</b> (UNII: 70097M6I30)	
<b>MANNITOL</b> (UNII: 3OWL53L36A)	
<b>MICROCRYSTALLINE CELLULOSE 102</b> (UNII: PNR0YF693Y)	
<b>SILICON DIOXIDE</b> (UNII: ETJ7Z6XBU4)	

## Product Characteristics

<b>Color</b>	WHITE (white to slightly yellow)	<b>Score</b>	no score
<b>Shape</b>	ROUND	<b>Size</b>	9mm
<b>Flavor</b>		<b>Imprint Code</b>	M;EVD;2
<b>Contains</b>			

## Packaging

#	Item Code	Package Description	Marketing Start Date	Marketing End Date
1	NDC:0378-0005-85	4 in 1 CARTON	10/01/2021	
1		7 in 1 BLISTER PACK; Type 0: Not a Combination Product		

## Marketing Information

Marketing Category	Application Number or Monograph Citation	Marketing Start Date	Marketing End Date
ANDA	ANDA210130	10/01/2021	

## EVEROLIMUS

everolimus tablet, for suspension

## Product Information

<b>Product Type</b>	HUMAN PRESCRIPTION DRUG	<b>Item Code (Source)</b>	NDC:0378-0006
<b>Route of Administration</b>	ORAL		

## Active Ingredient/Active Moiety

Ingredient Name	Basis of Strength	Strength
-----------------	-------------------	----------

<b>EVEROLIMUS</b> (UNII: 9HW64Q8G6G) (EVEROLIMUS - UNII:9HW64Q8G6G)	EVEROLIMUS	3 mg
---	------------	------

### Inactive Ingredients

Ingredient Name	Strength
<b>ANHYDROUS LACTOSE</b> (UNII: 3SY5LH9PMK)	
<b>BUTYLATED HYDROXYTOLUENE</b> (UNII: 1P9D0Z171K)	
<b>CROSCARMELLOSE SODIUM</b> (UNII: M28OL1HH48)	
<b>CROSPVIDONE</b> (UNII: 2S7830E561)	
<b>HYPROMELLOSE 2910 (3 MPA.S)</b> (UNII: 0VUT3PMY82)	
<b>LACTOSE MONOHYDRATE</b> (UNII: EWQ57Q8I5X)	
<b>MAGNESIUM STEARATE</b> (UNII: 70097M6I30)	
<b>MANNITOL</b> (UNII: 3OWL53L36A)	
<b>MICROCRYSTALLINE CELLULOSE 102</b> (UNII: PNR0YF693Y)	
<b>SILICON DIOXIDE</b> (UNII: ETJ7Z6XBU4)	

### Product Characteristics

<b>Color</b>	WHITE (white to slightly yellow)	<b>Score</b>	no score
<b>Shape</b>	ROUND	<b>Size</b>	10mm
<b>Flavor</b>		<b>Imprint Code</b>	M;EVD;3
<b>Contains</b>			

### Packaging

#	Item Code	Package Description	Marketing Start Date	Marketing End Date
1	NDC:0378-0006-85	4 in 1 CARTON	10/01/2021	
1		7 in 1 BLISTER PACK; Type 0: Not a Combination Product		

### Marketing Information

Marketing Category	Application Number or Monograph Citation	Marketing Start Date	Marketing End Date
ANDA	ANDA210130	10/01/2021	

## EVEROLIMUS

everolimus tablet, for suspension

### Product Information

<b>Product Type</b>	HUMAN PRESCRIPTION DRUG	<b>Item Code (Source)</b>	NDC:0378-0007
<b>Route of Administration</b>	ORAL		

**Active Ingredient/Active Moiety**

<b>Ingredient Name</b>	<b>Basis of Strength</b>	<b>Strength</b>
EVEROLIMUS (UNII: 9HW64Q8G6G) (EVEROLIMUS - UNII:9HW64Q8G6G)	EVEROLIMUS	5 mg

**Inactive Ingredients**

<b>Ingredient Name</b>	<b>Strength</b>
ANHYDROUS LACTOSE (UNII: 3SY5LH9PMK)	
BUTYLATED HYDROXYTOLUENE (UNII: 1P9D0Z171K)	
CROSCARMELLOSE SODIUM (UNII: M28OL1HH48)	
CROSPVIDONE (UNII: 2S7830E561)	
HYPROMELLOSE 2910 (3 MPA.S) (UNII: 0VUT3PMY82)	
LACTOSE MONOHYDRATE (UNII: EWQ57Q8I5X)	
MAGNESIUM STEARATE (UNII: 70097M6I30)	
MANNITOL (UNII: 3OWL53L36A)	
MICROCRYSTALLINE CELLULOSE 102 (UNII: PNR0YF693Y)	
SILICON DIOXIDE (UNII: ETJ7Z6XBU4)	

**Product Characteristics**

<b>Color</b>	WHITE (white to slightly yellow)	<b>Score</b>	no score
<b>Shape</b>	ROUND	<b>Size</b>	11mm
<b>Flavor</b>		<b>Imprint Code</b>	M;EVD;5
<b>Contains</b>			

**Packaging**

<b>#</b>	<b>Item Code</b>	<b>Package Description</b>	<b>Marketing Start Date</b>	<b>Marketing End Date</b>
1	NDC:0378-0007-85	4 in 1 CARTON	10/01/2021	
1		7 in 1 BLISTER PACK; Type 0: Not a Combination Product		

**Marketing Information**

<b>Marketing Category</b>	<b>Application Number or Monograph Citation</b>	<b>Marketing Start Date</b>	<b>Marketing End Date</b>
ANDA	ANDA210130	10/01/2021	

**Labeler** - Mylan Pharmaceuticals Inc. (059295980)

Revised: 5/2023

Mylan Pharmaceuticals Inc.