

BSS PLUS - balanced salt solution enriched with bicarbonate, dextrose, and glutathione
Alcon Laboratories, Inc.

BSS PLUS™
STERILE IRRIGATING SOLUTION
(balanced salt solution enriched with bicarbonate, dextrose, and glutathione)

DESCRIPTION

BSS PLUS™ is a sterile intraocular irrigating solution for use during all intraocular surgical procedures, including those requiring a relatively long intraocular perfusion time (e.g., pars plana vitrectomy, phacoemulsification, extra capsular cataract extraction/lens aspiration, anterior segment reconstruction, etc.). The solution does not contain a preservative and should be prepared just prior to use in surgery.

Part I: Part I is a sterile 480 mL solution in a 500 mL single-dose bag to which the Part II concentrate is added. Each mL of Part I contains: sodium chloride 7.44 mg, potassium chloride 0.395 mg, dibasic sodium phosphate 0.433 mg, sodium bicarbonate 2.19 mg, hydrochloric acid and/or sodium hydroxide (to adjust pH), in water for injection.

Part II: Part II is a sterile concentrate in a 20 mL single-dose vial for addition to Part I. Each mL of Part II contains: calcium chloride dihydrate 3.85 mg, magnesium chloride hexahydrate 5 mg, dextrose 23 mg, glutathione disulfide (oxidized glutathione) 4.6 mg, in water for injection.

After addition of BSS PLUS solution Part II to the Part I bag, each mL of the reconstituted product contains: sodium chloride 7.14 mg, potassium chloride 0.38 mg, calcium chloride dihydrate 0.154 mg, magnesium chloride hexahydrate 0.2 mg, dibasic sodium phosphate 0.42 mg, sodium bicarbonate 2.1 mg, dextrose 0.92 mg, glutathione disulfide (oxidized glutathione) 0.184 mg, hydrochloric acid and/or sodium hydroxide (to adjust pH), in water for injection.

The reconstituted product has a pH of approximately 7.4. Osmolality is approximately 305 mOsm.

CLINICAL PHARMACOLOGY

None of the components of BSS PLUS solution are foreign to the eye, and BSS PLUS solution has no pharmacological action. Human perfused cornea studies have shown BSS PLUS solution to be an effective irrigation solution for providing corneal detumescence and maintaining corneal endothelial integrity during intraocular perfusion. An *in vivo* study in rabbits has shown the BSS PLUS solution is more suitable than normal saline or Balanced Salt Solution for intravitreal irrigation because BSS PLUS solution contains the appropriate bicarbonate, pH, and ionic composition necessary for the maintenance of normal retinal electrical activity. Human *in vivo* studies have demonstrated BSS PLUS solution to be safe and effective when used during surgical procedures such as pars plana vitrectomy, phacoemulsification, cataract extraction/lens

aspiration, anterior segment reconstruction. No differences have been observed between adults and pediatric patients following use of this drug product.

INDICATIONS AND USAGE

BSS PLUS solution is indicated for use as an intraocular irrigating solution during intraocular surgical procedures involving perfusion of the eye.

CONTRAINDICATIONS

There are no specific contraindications to the use of BSS PLUS solution; however, contraindications for the surgical procedure during which BSS PLUS solution is to be used should be strictly adhered to.

WARNINGS

For IRRIGATION during ophthalmic surgery only. Not for injection or intravenous infusion. Do not use unless product is clear, seal is intact and container is undamaged. Do not use if product is discolored or contains a precipitate.

PRECAUTIONS

DO NOT USE BSS PLUS solution UNTIL PART I IS FULLY RECONSTITUTED WITH PART II. Discard unused contents. BSS PLUS does not contain a preservative; therefore, do not use this container for more than one patient. DISCARD ANY UNUSED PORTION SIX HOURS AFTER PREPARATION. Studies suggest that intraocular irrigating solutions which are iso-osmotic with normal aqueous fluids should be used with caution in diabetic patients undergoing vitrectomy since intraoperative lens changes have been observed.

There have been reports of corneal clouding or edema following ocular surgery in which BSS PLUS solution was used as an irrigating solution. As in all surgical procedures appropriate measures should be taken to minimize trauma to the cornea and other ocular tissues.

Preparation

Reconstitute **BSS PLUS** Intraocular Irrigating Solution just prior to use in surgery. Follow the same strict aseptic procedures in the reconstitution of **BSS PLUS** solution as is used for intravenous additives. Remove the **BSS PLUS solution** Part I (480 mL) bag from the clear overwrap. Remove the blue flip-off seal from the **BSS PLUS solution** Part II (20 mL) vial. Clean and disinfect the rubber stoppers on both containers by using sterile alcohol wipes. Transfer the contents of the Part II vial to the Part I bag using a **BSS PLUS solution** Dual-Spike Transfer Device (provided). An alternative method of solution transfer may be accomplished by using a 20 mL syringe to remove the Part II solution from the vial and transferring exactly 20 mL to the Part I container through the outer target area of the rubber stopper. An excess volume of Part II is provided in each vial. Gently agitate the contents to mix the solution. Place a sterile cap on the bag. Record the time and date of reconstitution and the patient's name on the bag label.

GERIATRIC USE

No overall differences in safety or effectiveness have been observed between elderly and younger patients.

ADVERSE REACTIONS

Postoperative inflammatory reactions as well as incidents of corneal edema and corneal decompensation have been reported. Their relationship to the use of BSS PLUS solution has not been established.

OVERDOSAGE

The solution has no pharmacological action and thus no potential for overdose. However, as with any intraocular surgical procedure, the duration of intraocular manipulation should be kept to a minimum.

DOSAGE AND ADMINISTRATION

The solution should be used according to the standard technique employed by the operating surgeon. For non-active irrigating system, use an administration set with an air-inlet in the plastic spike since the bag does not contain a separate airway tube. Follow the directions for the particular administration set to be used. Insert the spike aseptically into the bag through the center target area of the rubber stopper. Allow the fluid to flow to remove air from the tubing before intraocular irrigation begins.

HOW SUPPLIED

BSS PLUS solution is supplied in two packages for reconstitution prior to use: a 500 mL bag containing 480 mL (Part I) and a 20 mL glass vial (Part II); both using grey butyl stoppers and aluminum seals. See the PRECAUTIONS section regarding reconstitution of the solution.

NDC 0065-0800-94

STORAGE AND HANDLING

Store Part I and Part II at 2° - 25°C (36° - 77°F). Discard prepared solution after six hours.

RECONSTITUTION INSTRUCTIONS

DIRECTIONS: Use Aseptic Technique

1. Remove the BSS PLUS™ solution Part I (480 mL) bag from the clear overwrap. Remove the blue flip-off seal from the BSS PLUS solution Part II (20 mL) vial. Prepare the stoppers on both parts by using sterile alcohol wipes.
2. Peel open a BSS PLUS solution Dual-Spike Transfer Device package (supplied) and remove the sterile transfer spike. NOTE: This device is vented permitting air to enter

vial during solution transfer, thereby preventing the creation of a vacuum inside the vial.

3. Remove protector from the white plastic piercing pin of the Dual-Spike Transfer Device.
4. Firmly grasp device from behind the flange and insert the white plastic piercing pin into the upright rubber stopper of the BSS PLUS solution Part II (20 mL) vial.
5. Remove guard from filter needle. Firmly grasp vial in the palm of one hand and with thumb and index finger, hold plastic flange against top of vial.
6. Hold the vial in the upright position, incline and immediately insert the transfer device into the center target of rubber stopper of the BSS PLUS solution Part I (480 mL) bag. (See illustration.) NOTE: Do not invert Part II (20mL) vial before or during spiking of the BSS PLUS solution Part I bag rubber stopper, until ready to initiate transfer.
7. Invert vial to initiate the transfer of Part II into Part I. If transfer does not occur immediately, gentle manipulation of the bag can initiate transfer. NOTE: An excess amount of BSS PLUS solution Part II is provided in each vial. A non-transferred solution residual of approximately 0.3 mL can be expected to remain in the vial.
8. Immediately remove vial (with spike attached) from the BSS PLUS solution Part I container and discard it after solution transfer has been completed.
9. Place a sterile safety cap over the rubber stopper of Part I if the solution is not going to be used immediately. Mix the solution gently until uniform. Record the patient's name and the date and time of reconstitution. BSS PLUS solution is now ready for use.

CAUTION: Reconstituted BSS PLUS solution must be used within six hours of mixing.

Discard any solution which has aged beyond that time. Never use the same bag of BSS PLUS solution on more than one patient.

Alternative Transfer Method

If preferred, the contents of the BSS PLUS Part II component may be aspirated with an 18-gauge cannula attached to a 20 mL syringe and then transferred into the Part I bag.

W300049019-0621

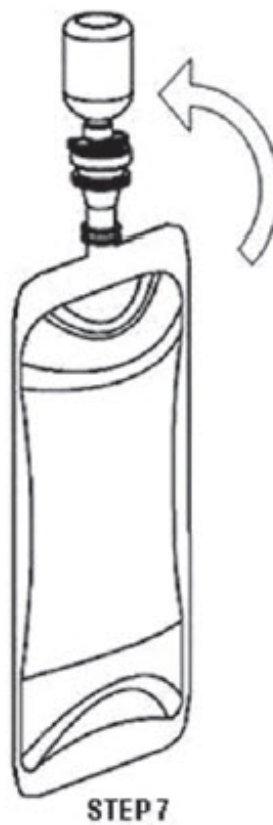
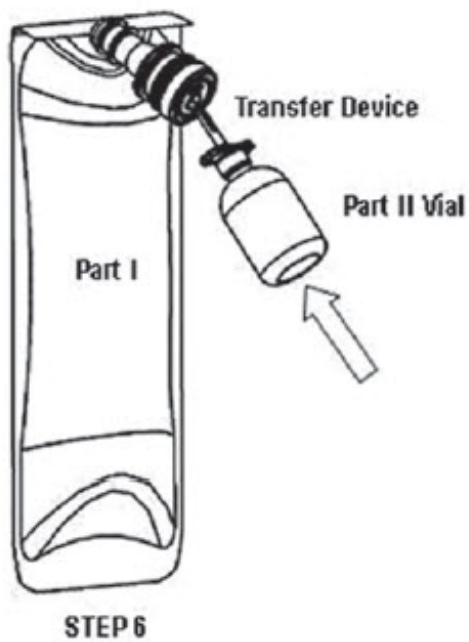

Alcon
Alcon Laboratories, Inc.
Fort Worth, Texas 76134 USA
© 2021 Alcon Inc.

PRINCIPAL DISPLAY PANEL

NDC 0065-0800-94

BSS PLUS™ PART I 480 mL

STERILE SOLUTION

**(For Reconstitution by Addition of BSS PLUS™
Concentrate Part II, 20 mL)***

SINGLE PATIENT USE ONLY

***Reconstitute just prior to use in Surgery.**

BSS PLUS™ 500 mL

STERILE INTRAOCULAR IRRIGATING SOLUTION
(balanced salt solution enriched with bicarbonate, dextrose, and glutathione)

After addition of BSS PLUS – Part II (20 mL), each mL contains: sodium chloride 7.14 mg, potassium chloride 0.38 mg, calcium chloride dihydrate 0.154 mg, magnesium chloride hexahydrate 0.2 mg, dibasic sodium phosphate 0.42 mg, sodium bicarbonate 2.1 mg, dextrose 0.92 mg, glutathione disulfide (oxidized glutathione) 0.184 mg, hydrochloric acid and/or sodium hydroxide (to adjust pH), in water for injection.

pH Approx. 7.4. Osmolality Approx. 305 mOsm/kg

Rx Only

**NOT FOR INJECTION OR
INTRAVENOUS INFUSION**

STORAGE: Store at 36° - 77°F (2° - 25°C)

**See Warnings, Precautions
and Preparation sections of
package insert.**

Alcon
Alcon Laboratories, Inc.
Fort Worth, Texas 76134 USA

LOT:
EXP.:
MFD.:

300049016-0821

Patient _____

Reconstituted at _____
AM/PM on _____

LOT:
EXP.:
MFD.:



300049016-0821

NDC 0065-0800-94

BSS PLUS™ PART I 480 mL

STERILE SOLUTION

(For Reconstitution by Addition of BSS PLUS™
Concentrate Part II, 20 mL)*

SINGLE PATIENT USE ONLY

*Reconstitute just prior to use in Surgery.

BSS PLUS™ 500 mL

STERILE INTRAOCULAR IRRIGATING SOLUTION

(balanced salt solution enriched with bicarbonate, dextrose, and glutathione)

After addition of BSS PLUS – Part II (20 mL), each mL contains: sodium chloride 7.14 mg, potassium chloride 0.38 mg, calcium chloride dihydrate 0.154 mg, magnesium chloride hexahydrate 0.2 mg, dibasic sodium phosphate 0.42 mg, sodium bicarbonate 2.1 mg, dextrose 0.92 mg, glutathione disulfide (oxidized glutathione) 0.184 mg, hydrochloric acid and/or sodium hydroxide (to adjust pH), in water for injection.

pH Approx. 7.4 . Osmolality Approx. 305 mOsm/kg

Rx Only

**NOT FOR INJECTION OR
INTRAVENOUS INFUSION**

STORAGE: Store at 36° - 77°F (2° - 25°C)



See Warnings, Precautions
and Preparation sections of

Alcon

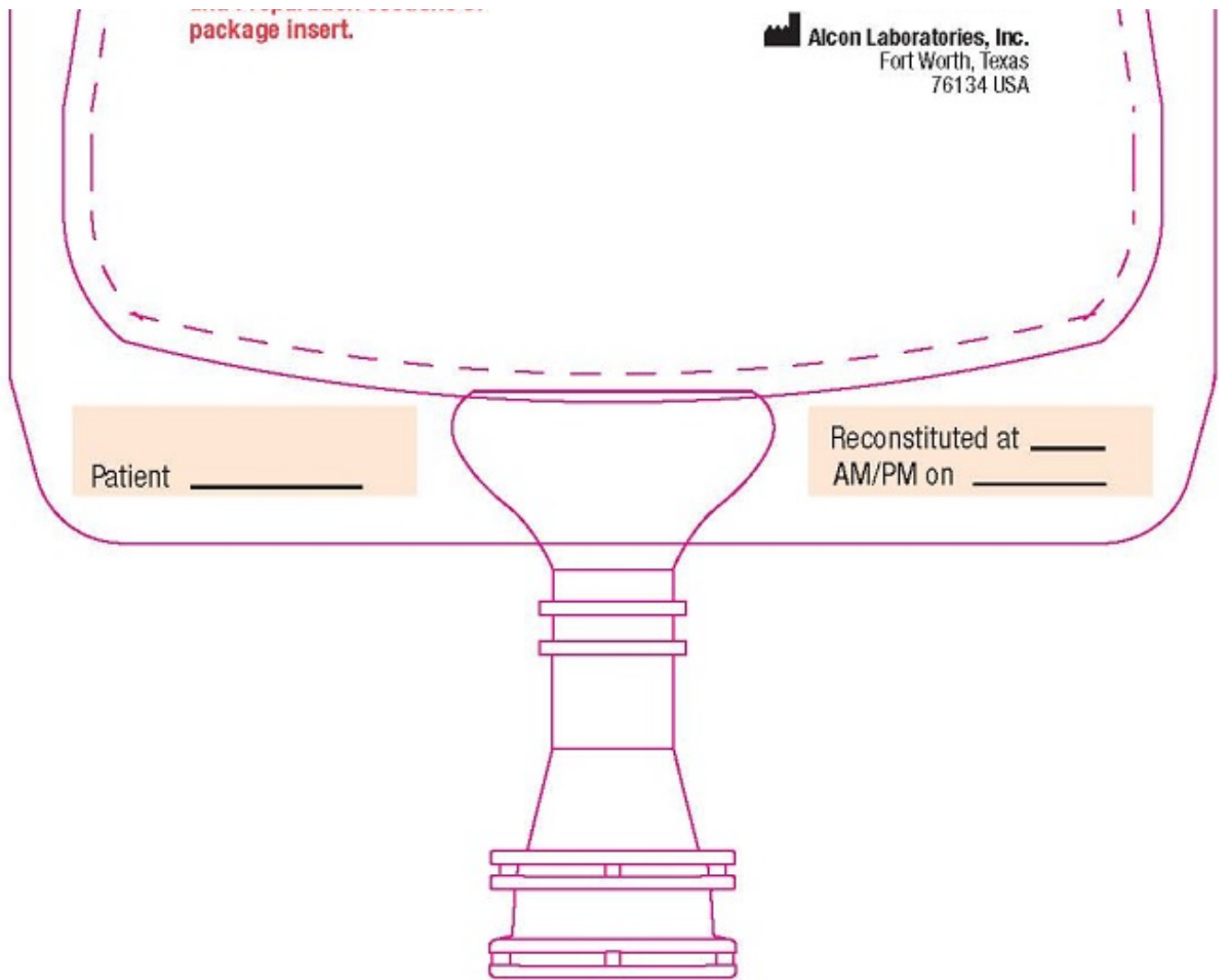

NDC 0065-0800-94

BSS PLUS® PART I 480 mL

STERILE SOLUTION

(For Reconstitution by Addition of BSS PLUS® Concentrate Part II, 20 mL)*

SINGLE PATIENT USE ONLY

***Reconstitute just prior to use in Surgery.**

BSS PLUS* 500 mL

STERILE INTRAOCULAR IRRIGATING SOLUTION

(balanced salt solution enriched with bicarbonate, dextrose, and glutathione)

After addition of BSS PLUS - Part II (20 mL), each mL contains: sodium chloride 7.14 mg, potassium chloride 0.38 mg, calcium chloride dihydrate 0.154 mg, magnesium

chloride hexahydrate 0.2 mg, dibasic sodium phosphate 0.42 mg, sodium bicarbonate 2.1 mg, dextrose 0.92 mg, glutathione disulfide (oxidized glutathione) 0.184 mg, hydrochloric acid and/or sodium hydroxide (to adjust pH), in water for injection.

pH Approx. 7.4. Osmolality Approx. 305 mOsm/kg

Rx Only

**NOT FOR INJECTION OR
INTRAVENOUS INFUSION**

STORAGE: Store at 36° - 77°F (2° - 25°C)

**See Warnings, Precautions
and Preparation sections of
package insert.**

Alcon®

a Novartis company

Alcon Laboratories, Inc.

Fort Worth, Texas 76134 USA

© 2013, 2015 Novartis

LOT:

EXP.:

MFD.:

9012637-1115

Patient _____

Reconstituted at _____

AM/PM on _____

LOT: _____
EXP.: _____
MFD.: _____



9012837-1115

NDC 0065-0800-94

BSS PLUS® PART I 480 mL

STERILE SOLUTION

(For Reconstitution by Addition of BSS PLUS®
Concentrate Part II, 20 mL)*

SINGLE PATIENT USE ONLY

*Reconstitute just prior to use in Surgery.

BSS PLUS® 500 mL

STERILE INTRAOCULAR IRRIGATING SOLUTION

(balanced salt solution enriched with bicarbonate, dextrose, and glutathione)

After addition of BSS PLUS – Part II (20 mL), each mL contains: sodium chloride 7.14 mg, potassium chloride 0.38 mg, calcium chloride dihydrate 0.154 mg, magnesium chloride hexahydrate 0.2 mg, dibasic sodium phosphate 0.42 mg, sodium bicarbonate 2.1 mg, dextrose 0.92 mg, glutathione disulfide (oxidized glutathione) 0.184 mg, hydrochloric acid and/or sodium hydroxide (to adjust pH), in water for injection.

pH Approx. 7.4 . Osmolality Approx. 305 mOsm/kg

Rx Only

**NOT FOR INJECTION OR
INTRAVENOUS INFUSION**

STORAGE: Store at 36° - 77°F (2° - 25°C)



See Warnings, Precautions
and Preparation sections of
package insert.

Alcon®
a Novartis company

 Alcon Laboratories, Inc.
Fort Worth, Texas
76134 USA

© 2013, 2015 Novartis

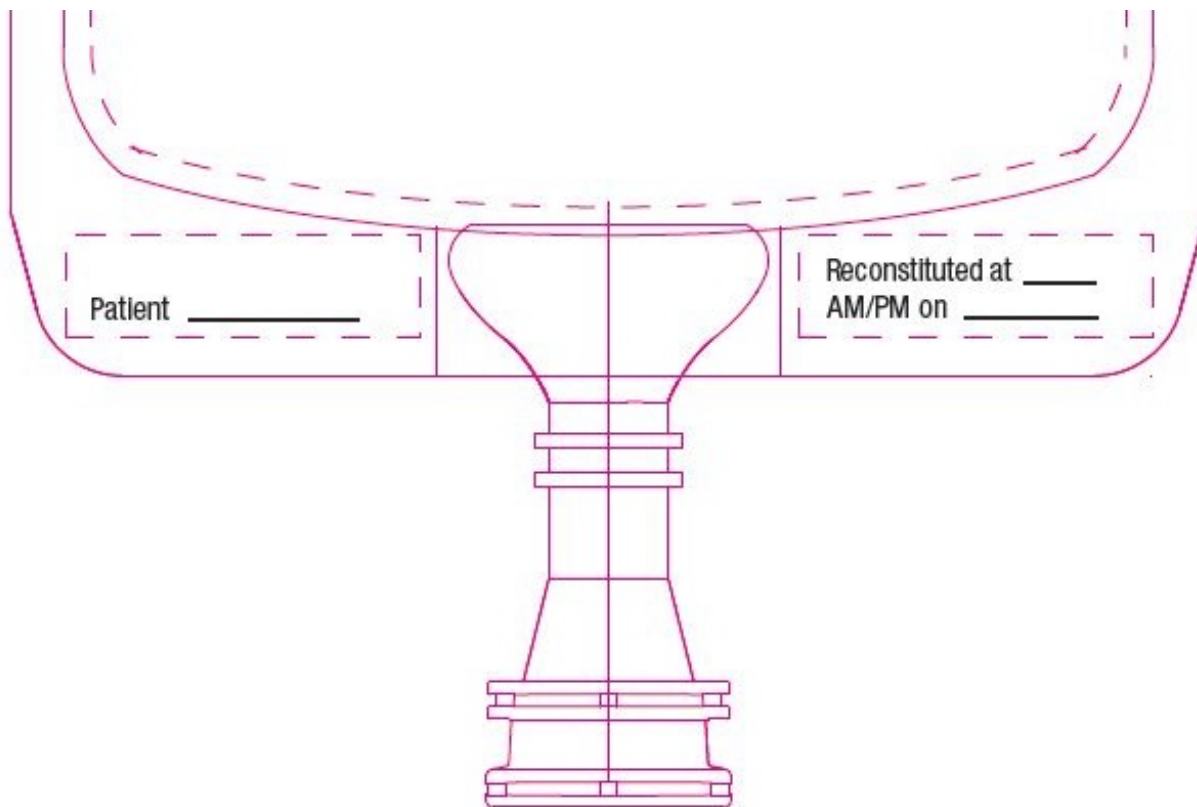

NDC 0065-0800-94 20mL

BSS PLUS™
CONCENTRATE PART II
(Sterile Solution for Reconstitution)

Alcon
Alcon Laboratories Inc.
Fort Worth, Texas 76134 USA

Each mL contains: calcium chloride dihydrate 3.85 mg, magnesium chloride hexahydrate 5 mg, dextrose 23 mg, glutathione disulfide (oxidized glutathione) 4.6 mg, in water for injection.

For Addition to **BSS PLUS™ — Part I** (480 mL) only.
See **Preparation** section of package insert.

WARNINGS: Not for injection or intravenous infusion – for reconstitution of irrigation solution only. Do not use unless product is clear, seal is intact and container is undamaged. Do not use if product is discolored or contains a precipitate.

PRECAUTIONS: Discard unused contents. Do not use this container for more than one patient.

Storage: Store at 2-25°C (36-77°F).

Rx Only

300049017-0621

LOT:

EXP.:

MFD.:

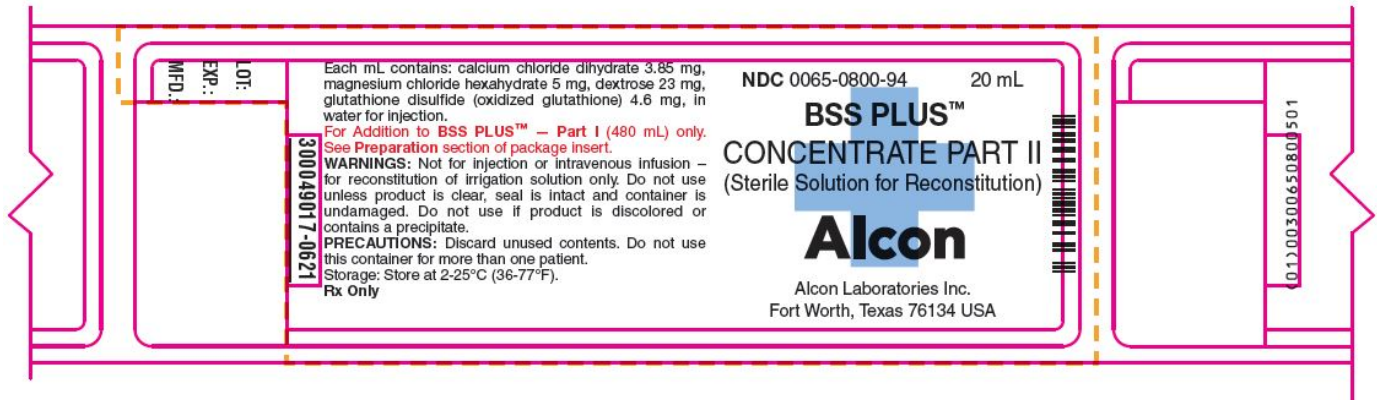

NDC 0065-0800-94 20mL

BSS PLUS®
CONCENTRATE PART II
(Sterile Solution for Reconstitution)

Alcon®
Alcon Laboratories Inc.
Fort Worth, Texas 76134 USA

Each mL contains: calcium chloride dihydrate 3.85 mg, magnesium chloride hexahydrate 5 mg, dextrose 23 mg, glutathione disulfide (oxidized glutathione) 4.6 mg, in water for injection.

For Addition to **BSS PLUS® — Part I** (480 mL) only.
See **Preparation** section of package insert.

WARNINGS: Not for injection or intravenous infusion – for reconstitution of irrigation solution only. Do not use unless product is clear, seal is intact and container is undamaged. Do not use if product is discolored or contains a precipitate.

PRECAUTIONS: Discard unused contents. Do not use this container for more than one patient.

Storage: Store at 2-25°C (36-77°F).

Rx Only

© 2002-2003, 2013, 2015 Novartis

H14141-1115

LOT:

EXP.:

MFD.:



BSS PLUS™

**STERILE INTRAOCULAR
IRRIGATING SOLUTION**

(balanced salt solution enriched with bicarbonate, dextrose, and glutathione)

1 **Vial BSS PLUS®** Concentrate Part II Sterile Solution for Reconstitution with **BSS PLUS solution** Part 1 Only

1 **BSS PLUS solution** Dual Spike Transfer Device

1 **BSS PLUS solution** Product Package Insert

WARNINGS: For IRRIGATION during ophthalmic surgery only. Not for injection or intravenous infusion. Do not use unless product is clear, seal is intact and container is undamaged. Do not use if product is discolored or contains a precipitate.

Store at 2° - 25°C (36° - 77°F).

Alcon

Alcon Laboratories, Inc.
Fort Worth, Texas 76134 USA

300049018-0621

PRECAUTIONS: DO NOT USE **BSS PLUS*** Sterile Intraocular Irrigating Solution, UNTIL PART I IS FULLY RECONSTITUTED WITH PART II. Discard unused contents. **BSS PLUS** solution does not contain a preservative; therefore, do not use this container for more than one patient. DISCARD ANY UNUSED PORTION SIX HOURS AFTER PREPARATION. Studies suggest that intraocular irrigating solutions which are iso-osmotic with normal aqueous fluids should be used with caution in diabetic patients undergoing vitrectomy since intraoperative lens changes have been observed.

There have been reports of corneal clouding or edema following ocular surgery in which **BSS PLUS** solution was used as irrigating solution. As in all surgical procedures, appropriate measures should be taken to minimize trauma to the cornea and other ocular tissues.

LOT:

EXP:

MFD:

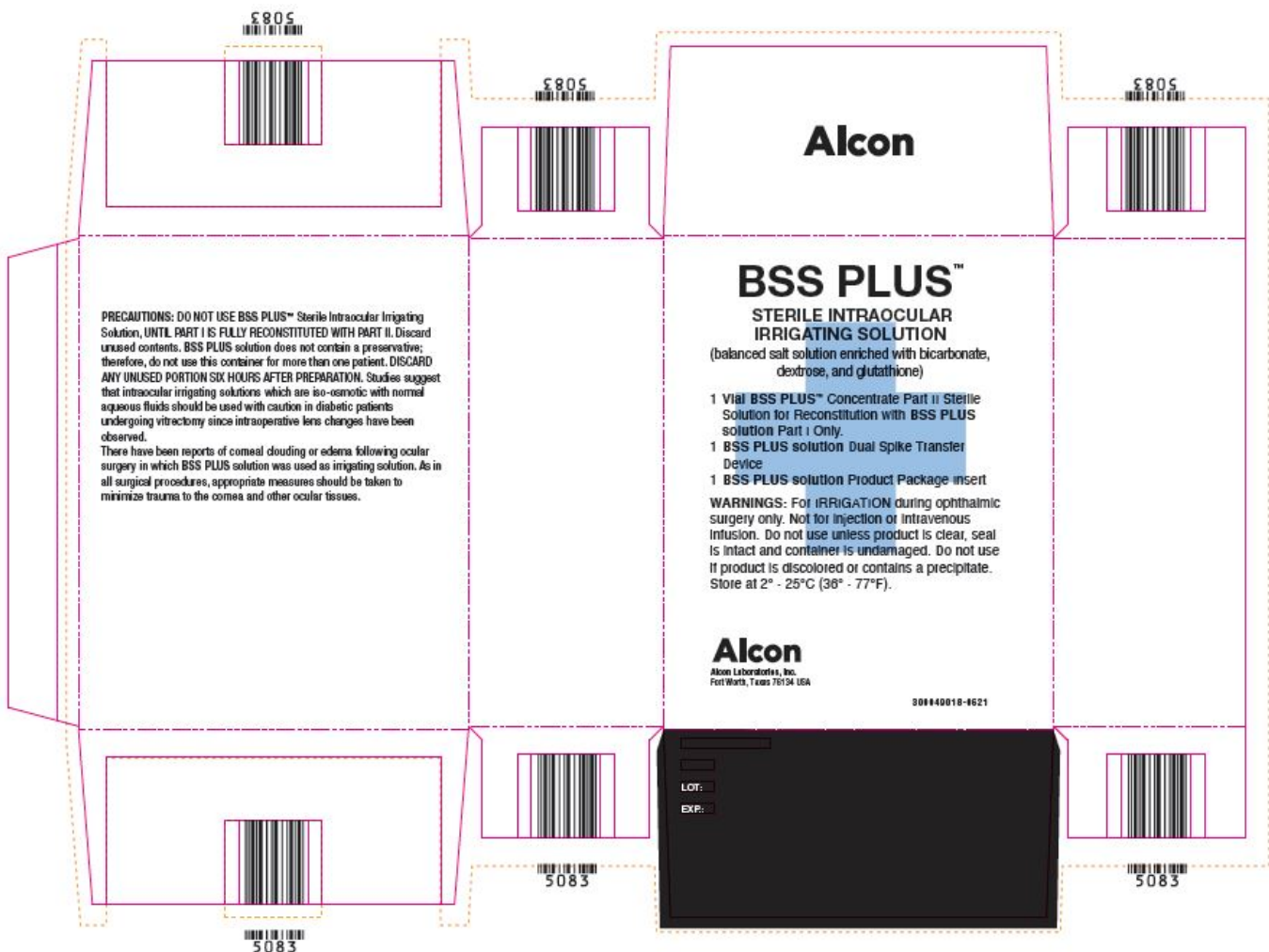

BSS PLUS®

**STERILE INTRAOCULAR
IRRIGATING SOLUTION**

(balanced salt solution enriched with bicarbonate, dextrose, and glutathione)

- 1 **Vial BSS PLUS®** Concentrate Part II Sterile Solution for Reconstitution with **BSS PLUS solution** Part 1 Only
- 1 **BSS PLUS solution** Dual Spike Transfer Device
- 1 **BSS PLUS solution** Product Package Insert

WARNINGS: For IRRIGATION during ophthalmic surgery only. Not for injection or intravenous infusion. Do not use unless product is clear, seal is intact and container is undamaged. Do not use if product is discolored or contains a precipitate.

Store at 2° - 25°C (36° - 77°F).

Alcon®

a Novartis company

Alcon Laboratories, Inc.
Fort Worth, Texas 76134 USA
© 2013, 2014, 2015 Novartis

9012757-0116

PRECAUTIONS: DO NOT USE **BSS PLUS*** Sterile Intraocular Irrigating Solution, UNTIL PART I IS FULLY RECONSTITUTED WITH PART II. Discard unused contents. **BSS PLUS** solution does not contain a preservative; therefore, do not use this container for more than one patient. DISCARD ANY UNUSED PORTION SIX HOURS AFTER PREPARATION. Studies suggest that intraocular irrigating solutions which are iso-osmotic with normal aqueous fluids should be used with caution in diabetic patients undergoing vitrectomy since intraoperative lens changes have been observed.

There have been reports of corneal clouding or edema following ocular surgery in which **BSS PLUS** solution was used as irrigating solution. As in all surgical procedures, appropriate measures should be taken to minimize trauma to the cornea and other ocular tissues.

LOT:

EXP:

MFD:

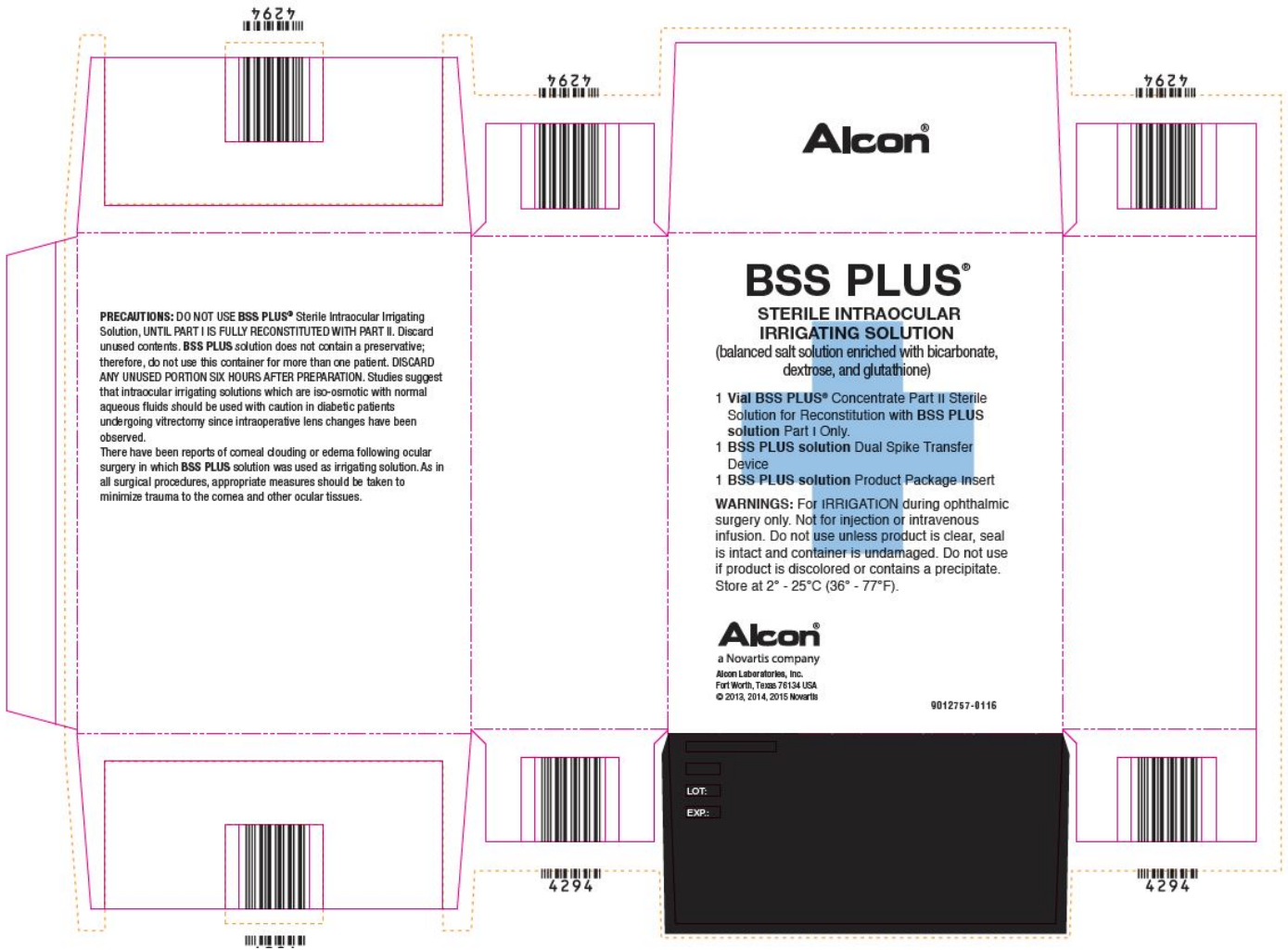

BSS PLUS

balanced salt solution enriched with bicarbonate, dextrose, and glutathione kit

Product Information

Product Type	HUMAN PRESCRIPTION DRUG	Item Code (Source)	NDC:0065-0800
---------------------	-------------------------	---------------------------	---------------

Packaging

#	Item Code	Package Description	Marketing Start Date	Marketing End Date
1	NDC:0065-0800-94	1 in 1 PACKAGE; Type 0: Not a Combination Product	06/20/2013	

Quantity of Parts

Part #	Package Quantity	Total Product Quantity
Part 1	1 BAG	480 mL
Part 2	1 VIAL, GLASS	20 mL

Part 1 of 2

PART 1

balanced salt solution enriched with bicarbonate, dextrose, and glutathione solution

Product Information

Route of Administration OPTHALMIC

Active Ingredient/Active Moiety

Ingredient Name	Basis of Strength	Strength
Sodium Chloride (UNII: 451W47IQ8X) (Sodium Cation - UNII:LYR4M0NH37, Chloride Ion - UNII:Q32ZN48698)	Sodium Chloride	7.44 mg in 1 mL
Potassium Chloride (UNII: 660YQ98I10) (Potassium Cation - UNII:295O53K152, Chloride Ion - UNII:Q32ZN48698)	Potassium Chloride	0.395 mg in 1 mL
Sodium Phosphate, Dibasic (UNII: GR686LBA74) (Sodium Cation - UNII:LYR4M0NH37, Phosphate Ion - UNII:NK08V8K8HR)	Sodium Phosphate, Dibasic	0.433 mg in 1 mL
Sodium Bicarbonate (UNII: 8MDF5V39QO) (Sodium Cation - UNII:LYR4M0NH37, Bicarbonate Ion - UNII:HN1ZRA3Q20)	Sodium Bicarbonate	2.19 mg in 1 mL

Inactive Ingredients

Ingredient Name	Strength
Hydrochloric Acid (UNII: QTT17582CB)	
Sodium Hydroxide (UNII: 55X04QC32I)	
Water (UNII: 059QF0KO0R)	

Packaging

#	Item Code	Package Description	Marketing Start Date	Marketing End Date
1		480 mL in 1 BAG; Type 0: Not a Combination Product		

Marketing Information

Marketing Category	Application Number or Monograph Citation	Marketing Start Date	Marketing End Date
NDA	NDA018469	06/20/2013	

Part 2 of 2

PART II

calcium chloride, magnesium chloride, dextrose, and glutathione concentrate

Product Information

Route of Administration OPTHALMIC

Active Ingredient/Active Moiety

Ingredient Name	Basis of Strength	Strength
Calcium Chloride (UNII: M4I0D6VV5M) (Calcium Cation - UNII:2M83C4R6ZB, Chloride Ion - UNII:Q32ZN48698)	Calcium Chloride	3.85 mg in 1 mL
Magnesium Chloride (UNII: 02F3473H9O) (Magnesium Cation - UNII:T6V3LHY838, Chloride Ion - UNII:Q32ZN48698)	Magnesium Chloride	5 mg in 1 mL
Dextrose (UNII: IY9XDZ35W2) (Dextrose - UNII:IY9XDZ35W2)	Dextrose	23 mg in 1 mL
Oxiglutatione (UNII: ULW86O013H) (Oxiglutatione - UNII:ULW86O013H)	Oxiglutatione	4.6 mg in 1 mL

Inactive Ingredients

Ingredient Name	Strength
Water (UNII: 059QF0KO0R)	

Packaging

#	Item Code	Package Description	Marketing Start Date	Marketing End Date
1		20 mL in 1 VIAL, GLASS; Type 0: Not a Combination Product		

Marketing Information

Marketing Category	Application Number or Monograph Citation	Marketing Start Date	Marketing End Date
NDA	NDA018469	06/20/2013	

Marketing Information

Marketing Category	Application Number or Monograph Citation	Marketing Start Date	Marketing End Date
NDA	NDA018469	06/20/2013	

Labeler - Alcon Laboratories, Inc. (008018525)

Registrant - Alcon Laboratories, Inc. (008018525)

Establishment

Name	Address	ID/FEI	Business Operations
------	---------	--------	---------------------

Revised: 6/2022

Alcon Laboratories, Inc.