

**ECLIPSE SPF 50 ALL SHADES- titanium dioxide, zinc oxide lotion
SCIENCE OF SKINCARE LLC**

Eclipse SPF 50 Non Tinted

Active Ingredients

TITANIUM DIOXIDE – 5.20%

Zinc Oxide – 1.10%

PURPOSE

SUNSCREEN

USES

- Helps hydrate and prevent sunburn.
- If used as directed with other sun protection measures (see Directions), decreases the risk of skin cancer and early skin aging caused by the sun

WARNINGS

- For external use only
- Do not use on damaged or broken skin
- When using this product keep out of eyes. Rinse with water to remove
- Stop use and ask a doctor if rash occurs
- Keep out of reach of children. If product is swallowed, get medical help or contact a Poison Control Center right away.

DIRECTIONS

- APPLY LIBERALLY 15 MINUTES BEFORE SUN EXPOSURE.
- REAPPLY:
 - AFTER 40 MINUTES OF SWIMMING OR SWEATING
 - IMMEDIATELY AFTER TOWEL DRYING
 - AT LEAST EVERY 2 HOURS
- Sun Protection Measures. Spending time in the sun increases your risk of skin cancer and early skin aging. To decrease this risk, regularly use a sunscreen with a broad spectrum SPF of 15 or higher and other sun protection measures including:
 - o limit time in the sun, especially from 10 a.m.-2 p.m.
 - o wear long-sleeve shirts, pants, hats, and sunglasses
- Children under 6 months: Ask a doctor

Other Information

Sun alert: Limiting sun exposure, wearing protective clothing, and using sunscreens may reduce the risk of skin cancer, and other harmful effects of the sun.

Questions or Comments?

Call Customer Care at (888) 804-4447

Inactive Ingredients

1,2-Hexanediol, Acrylates/C10-30 Alkyl Acrylate Crosspolymer, Alumina, Butylene Glycol, C12-15 Alkyl Benzoate, Caprylic/Capric Triglyceride, Caprylyl Glycol, Cetearyl Alcohol, Cetearyl Glucoside, Disodium EDTA, Dimethicone, Glyceryl Stearate, Methicone, Octyldodecyl Neopentanoate, PEG-100 Stearate, Polyhydroxystearic Acid, Sorbitan Laurate, Styrene/Acrylates Copolymer, Tocopherol, Tocopheryl Acetate, Triethoxycaprylylsilane, VP/Eicosene Copolymer, Water/Aqua/Eau, Xanthan Gum +/- Iron Oxides.

Package Label - Principal Display Panel

DESCRIPTION/VERSION#: Eclipse SPF 50+ - Professional Box		DATE: 1/24/22
DESIGNER/ARTIST: Rebecca	REQUESTED BY: Marketing	<input checked="" type="checkbox"/> NEW PROJECT <input type="checkbox"/> UPDATE
ITEM #: BDX.1361.300.2302		
CHANGES MADE: CAD 26645A1 ABIT		
<input type="checkbox"/> 4-COLOR PROCESS/CMYK	<input checked="" type="checkbox"/> PMS 072C	<input checked="" type="checkbox"/> PMS 032 C
<input checked="" type="checkbox"/> SPOT COLOR/PANTONE		White (QR Code)
PAPER STOCK: 18 PT SBS Board	<input checked="" type="checkbox"/> GLOSS UV COATING	
OVERALL SIZE: 12.210" x 12.958"	<input checked="" type="checkbox"/> DIE CUT	<input checked="" type="checkbox"/> FOLD LINE

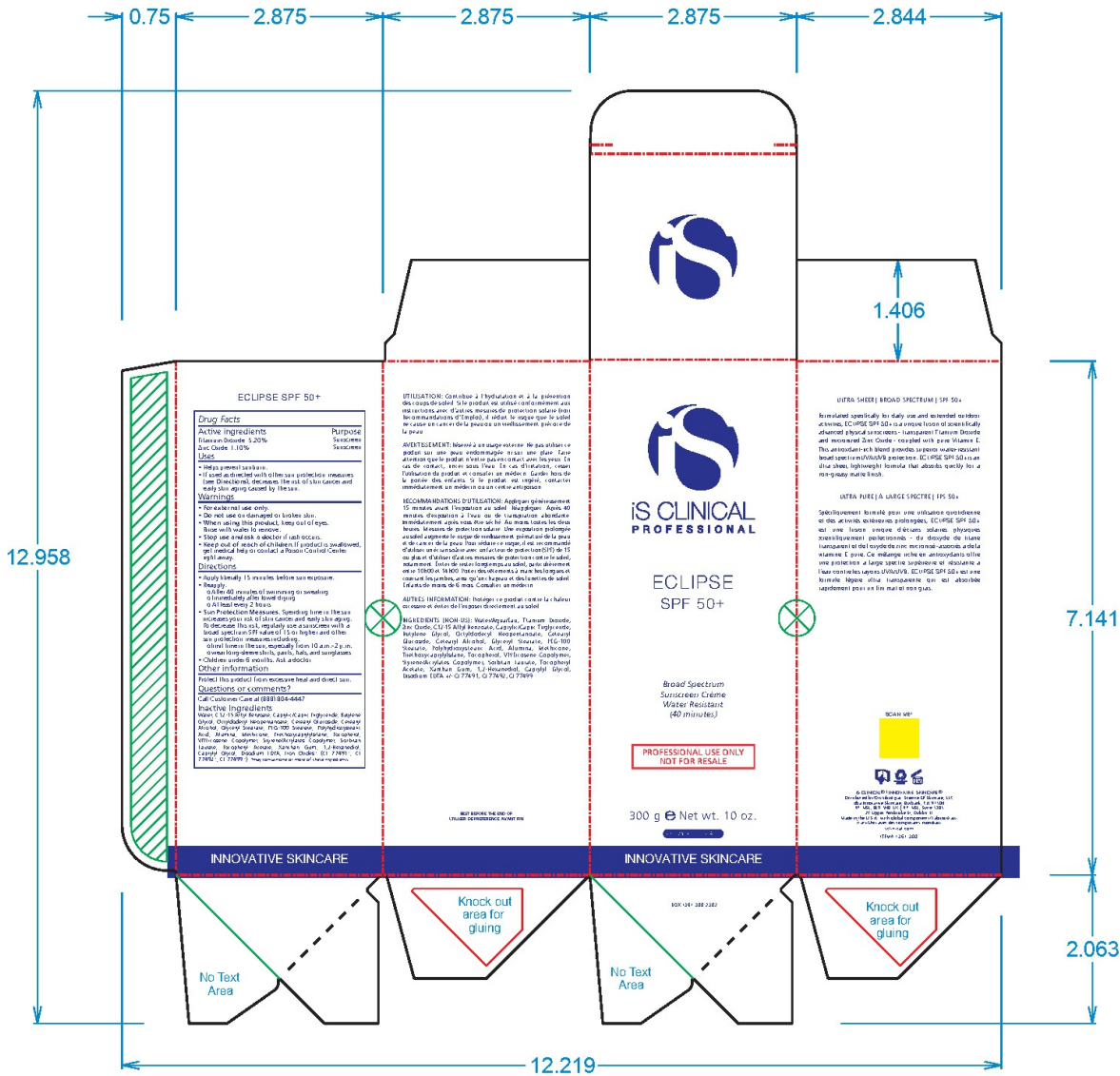

Drug Facts

Active ingredients

Titanium Dioxide 5.20%
Zinc Oxide 1.10%

Purpose

Sunscreen
Sunscreen

Uses

- Helps prevent sunburn.
- If used as directed with other sun protection measures (see Directions), decreases the risk of skin cancer and

ECLIPSE SPF 50+

Broad Spectrum
Sunscreen Crème
Water Resistant
(40 minutes)

(see **Directions**), decreases the risk of skin cancer and early skin aging caused by the sun.

Warnings

- **For external use only.**
- **Do not use** on damaged or broken skin.
- **When using this product** keep out of eyes. Rinse with water to remove.
- **Stop use and ask a doctor** if rash occurs.
- **Keep out of reach of children.** If product is swallowed, get medical help or contact a Poison Control Center right away.

Directions

- Apply liberally 15 minutes before sun exposure.
- Reapply:
 - After 40 minutes of swimming or sweating
 - Immediately after towel drying
 - At least every 2 hours
- **Sun Protection Measures.** Spending time in the sun increases your risk of skin cancer and early skin aging. To decrease this risk, regularly use a sunscreen with a broad spectrum SPF of 15 or higher and other sun protection measures including:
 - limit time in the sun, especially from 10 a.m.-2 p.m.
 - wear long-sleeve shirts, pants, hats, and sunglasses
- Children under 6 months: Ask a doctor

Other information

Protect this product from excessive heat and direct sun.

Questions or comments?

Call Customer Care at (888) 804-4447

Inactive ingredients

Water, C12-15 Alkyl Benzoate, Caprylic/Capric Triglyceride, Butylene Glycol, Octyldodecyl Neopentanoate, Cetearyl Glucoside, Cetearyl Alcohol, Glyceryl Stearate, PEG-100 Stearate, Polyhydroxystearic Acid, Alumina, Methicone, Triethoxycaprylylsilane, Tocopherol, VP/Eicosene Copolymer, Styrene/Acrylates Copolymer, Sorbitan Laurate, Tocopheryl Acetate, Xanthan Gum, 1,2-Hexanediol, Caprylyl Glycol, Disodium EDTA, Iron Oxides* (CI 77491*, CI 77492*, CI 77499*). *may contain one or more of these ingredients

LOT



EXP (BBE)





10 g e Net wt. 0.35 oz.

INGREDIENTS (NON-US):
Water/Aqua/Eau, Titanium Dioxide, Zinc Oxide, C12-15 Alkyl Benzoate, Caprylic/Capric Triglyceride, Butylene Glycol, Octyldodecyl Neopentanoate, Cetearyl Glucoside, Cetearyl Alcohol, Glyceryl Stearate, PEG-100 Stearate, Polyhydroxystearic Acid, Alumina, Methicone, Triethoxycaprylylsilane, Tocopherol, VP/Eicosene Copolymer, Styrene/Acrylates Copolymer, Sorbitan Laurate, Tocopheryl Acetate, Xanthan Gum, 1,2-Hexanediol, Caprylyl Glycol, Disodium EDTA +/- CI 77491, CI 77492, CI 77499.

SAMPLE ONLY
NOT FOR RESALE /
ECHANTILLON SEULEMENT
NE PAS REVENDRE



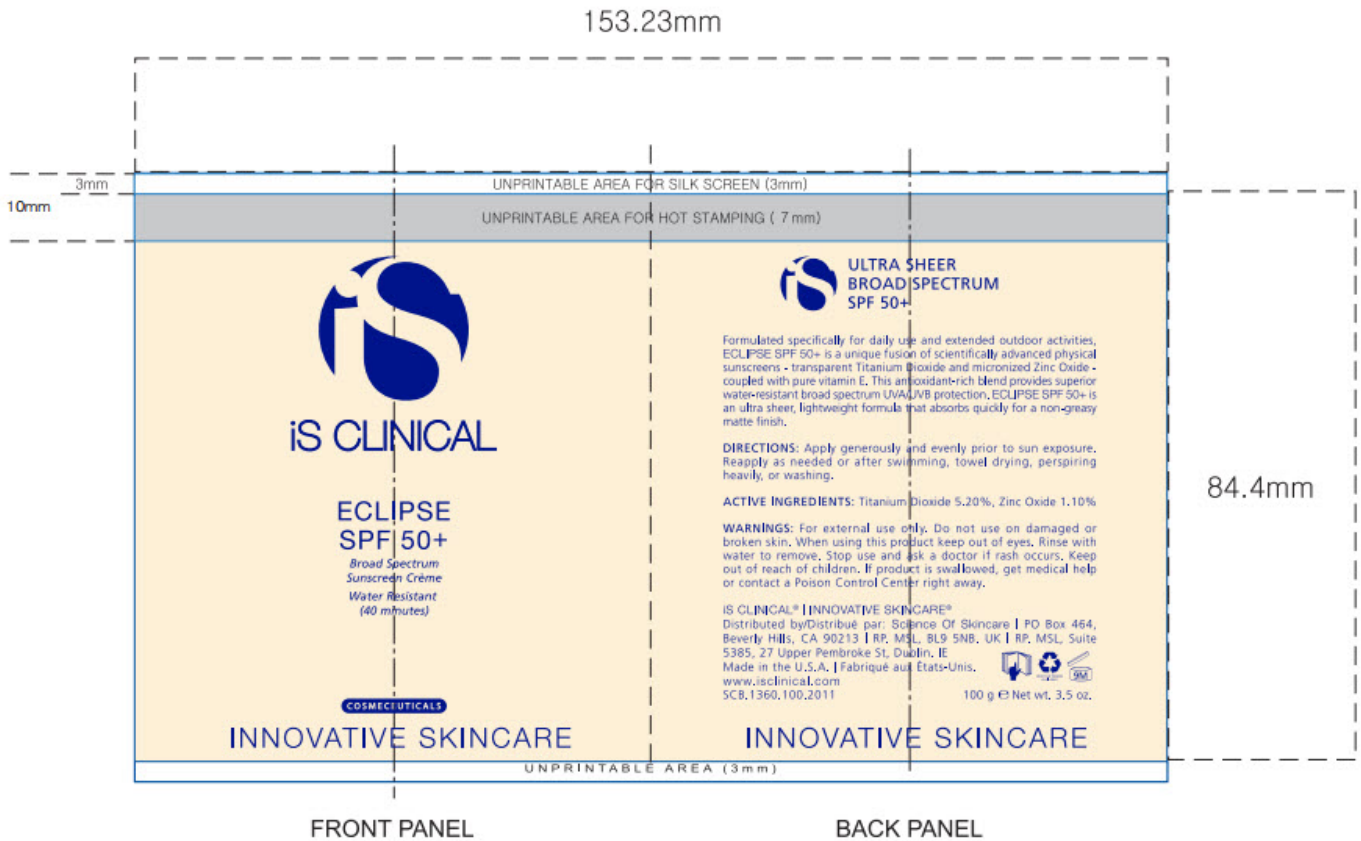

IS CLINICAL®
INNOVATIVE SKINCARE®
Distributed by/Distribué par:
Science Of Skincare | PO Box 464
Beverly Hills, CA 90213
RP. MSL, BL9 5NB. UK
RP. MSL, Suite 5385, 27 Upper
Pembroke St, Dublin. IE
Made in the U.S.A
Fabriqué aux États-Unis.
www.isclinical.com
LBL.1361.010.PKR.1937
ITEM# 1361.010.10PK
NPN 80060627

DESCRIPTION/VERSION#: ECLIPSE SPF 50+ - 100 g Screen			
DESIGNER/ARTIST: Cynthia	REQUESTED BY: Marketing - Chuck	DATE: 3/11/2020	
ITEM #: SCB.1360.100.2011	CAD #/VENDOR: AS100-J-PP (YONWOO)	<input type="checkbox"/> N/A	<input type="checkbox"/> NEW PROJECT <input checked="" type="checkbox"/> UPDATE
NOTES/CHANGES MADE: Update copy and color callout.			
<input type="checkbox"/> 4-COLOR PROCESS/CMYK	<input checked="" type="checkbox"/> SPOT COLOR/PANTONE	<input type="checkbox"/> RGB	 MATCH BLUE  Metallic Silver Spray
PAPER STOCK:		OVERALL SIZE: 153.23mm x 84.4 mm	
DIE LINE		FOLD LINE	
PRINTING FINISHING DETAILS: <input checked="" type="checkbox"/> GLOSS COATING			



DESCRIPTION/VERSION#: ECLIPSE SPF 50+ 300 g LABEL

DESIGNER/ARTIST: Cynthia	REQUESTED BY: Chuck	DATE: 10/9/2020
ITEM #: LBL.1361.300.2041	CAD #/VENDOR:	<input checked="" type="checkbox"/> N/A <input type="checkbox"/> NEW PROJECT <input checked="" type="checkbox"/> UPDATE
NOTES/CHANGES MADE: ingredients capitalized in romance copy.		
<input type="checkbox"/> 4-COLOR PROCESS/CMYK	<input checked="" type="checkbox"/> SPOT COLOR/PANTONE	<input type="checkbox"/> RGB
	 PMS 2738 C	 PMS 877 C
PAPER STOCK: Silver BOPP	OVERALL SIZE: 4.2259" x 8.2457"	
DIE LINE	FOLD LINE	
PRINTING PROCESS:	<input type="checkbox"/> OFFSET LITHOGRAPHY	<input checked="" type="checkbox"/> FLEXOGRAPHY <input type="checkbox"/> SILK SCREEN <input type="checkbox"/> DIGITAL PRINTING
PRINTING FINISHING DETAILS:	<input checked="" type="checkbox"/> UV GLOSS <input type="checkbox"/> GLOSS AQ <input type="checkbox"/> GLOSS VARNISH <input type="checkbox"/> SOFT TOUCH <input type="checkbox"/> GLOSS COATING	<input type="checkbox"/> MATTE UV <input type="checkbox"/> SATIN AQ <input type="checkbox"/> DULL VARNISH <input type="checkbox"/> SPOT UV

4.2259 x 8.2457

Drug Facts

Active ingredients	Purpose
Titanium Dioxide 5.20%	Sunscreen
Zinc Oxide 1.10%	Sunscreen

Uses

- Helps prevent sunburn.
- If used as directed with other sun protection measures (see **Directions**), decreases the risk of skin cancer and early skin aging caused by the sun.

Warnings

- For external use only.
- Do not use on damaged or broken skin.
- When using this product keep out of eyes. Rinse with water to remove.
- Stop use and ask a doctor if rash occurs.
- Keep out of reach of children. If product is swallowed, get medical help or contact a Poison Control Center right away.

Directions

- Apply liberally 15 minutes before sun exposure.
- Reapply:
 - o After 40 minutes of swimming or sweating
 - o Immediately after towel drying
 - o At least every 2 hours
- Sun Protection Measures. Spending time in the sun increases your risk of skin cancer and early skin aging. To decrease this risk, regularly use a sunscreen with a broad spectrum SPF of 15 or higher and other sun protection measures including:
 - o limit time in the sun, especially from 10 a.m.-2 p.m.
 - o wear long-sleeve shirts, pants, hats, and sunglasses
- Children under 6 months: Ask a doctor

Other information

Protect this product from excessive heat and direct sun.

Questions or comments?

Call Customer Care at (888) 804-4447

Inactive ingredients

Water, C12-15 Alkyl Benzoate, Caprylic/Capric Triglyceride, Butylene Glycol, Octyldodecyl Heptanoate, Cetylal Glycolide, Cetylal Alcohol, Glyceryl Stearate, PEG-100 Stearate, Polyhydroxystyrene Acid, Alumina, Methicone, Triethoxycaprylylsilane, Tocopherol, Vitecosene Copolymer, Styrene/Acrylates Copolymer, Sorbitan Laurate, Tocopheryl Acetate, Xanthan Gum, 1,2-Hexanediol, Caprylyl Glycol, Disodium EDTA, Iron Oxides (CI 77491*, CI 77492*, CI 77499*). *may contain one or more of these ingredients.



ECLIPSE SPF 50+
Broad Spectrum Sunscreen Crème
Water Resistant (40 minutes)

300 g e Net wt. 10 oz.

COSMECEUTICALS

INNOVATIVE SKINCARE

ECLIPSE SPF 50+

ULTRA SHEER | BROAD SPECTRUM | SPF 50+

Formulated specifically for daily use and extended outdoor activities, ECLIPSE SPF 50+ is a unique fusion of scientifically advanced physical sunscreens - transparent Titanium Dioxide and micronized Zinc Oxide - coupled with pure vitamin E. This antioxidant-rich blend provides superior water-resistant broad spectrum UVA/UVB protection. ECLIPSE SPF 50+ is an ultra sheer, lightweight formula that absorbs quickly for a non-greasy matte finish.

ULTRA SHEER | À LARGE SPECTRE | FPS 50+

Spécifiquement formulée pour une utilisation quotidienne et des activités extérieures prolongées, ECLIPSE SPF 50+ est une fusion unique d'écrans solaires physiques scientifiquement perfectionnés - dioxyde de titane transparent et oxyde de zinc micronisé associés à de la vitamine E pure. Ce mélange riche en antioxydants offre une protection à large spectre supérieure et résistante à l'eau contre les rayons UVA/UVB. ECLIPSE SPF 50+ est une formule légère ultra transparente qui est absorbée rapidement pour un fini mat non gras.

UTILISATION

Aide à prévenir les coups de soleil. Si le produit est utilisé conformément aux instructions avec d'autres mesures de protection solaire (voir Mode d'emploi), il réduit le risque que le soleil cause un cancer de la peau ou un vieillissement précoce de la peau.

AVERTISSEMENT

Réservez à un usage externe. Ne pas utiliser ce produit sur une peau endommagée ni sur une plaie. Faites attention que le produit n'entre pas en contact avec les yeux. En cas de contact, rincer sous l'eau. En cas d'irritation, cessez l'utilisation du produit et consultez un médecin. Garder hors de la portée des enfants. Si le produit est ingéré, contactez immédiatement un médecin ou un centre antipoison.

RECOMMANDATIONS D'UTILISATION

Appliquez généreusement 15 minutes avant l'exposition au soleil. Réappliquez. Après 40 minutes d'exposition à l'eau ou de transpiration abondante, immédiatement après sous séchage. Au moins toutes les deux heures. Mélanges de protection solaire. Une exposition prolongée au soleil augmente le risque de vieillissement prématuré de la peau et de cancer de la peau. Pour réduire ce risque, il est recommandé d'utiliser un écran solaire avec un facteur de protection (SPF) de 15 ou plus et d'utiliser d'autres mesures de protection contre le soleil, notamment: Éviter de rester longtemps au soleil, particulièrement entre 10h00 et 14h00. Porter des vêtements à manches longues et couvrant les jambes, ainsi qu'un chapeau et des lunettes de soleil enfants de moins de 6 ans. Consulter un médecin.

PLUS D'INFORMATION

Protéger ce produit contre la chaleur excessive et éviter de l'exposer directement au soleil.

IS CLINICAL, ® INNOVATIVE SKINCARE®
Distributed by Distributeur par: Science Of Skincare
P.O. Box 464, Beverly Hills, CA 90213
RF MSL, BLS SNE, IAK, RP, MSL, Suite 5385,
27 Lippin Peninsula St, Dublin, IE
Made in the U.S.A. / Fabriqué aux États-Unis.
www.isclinical.com
ITEM 1361.300
LBL 1361.300.2041

INGREDIENTS (NON-US): Water/Aqua/Eau, Titanium Dioxide, Zinc Oxide, C12-15 Alkyl Benzoate, Caprylic/Capric Triglyceride, Butylene Glycol, Octyldodecyl Heptanoate, Cetylal Glycolide, Cetylal Alcohol, Glyceryl Stearate, PEG-100 Stearate, Polyhydroxystyrene Acid, Alumina, Methicone, Triethoxycaprylylsilane, Tocopherol, Vitecosene Copolymer, Styrene/Acrylates Copolymer, Sorbitan Laurate, Tocopheryl Acetate, Xanthan Gum, 1,2-Hexanediol, Caprylyl Glycol, Disodium EDTA, Iron Oxides (CI 77491*, CI 77492*, CI 77499*). *may contain one or more of these ingredients.

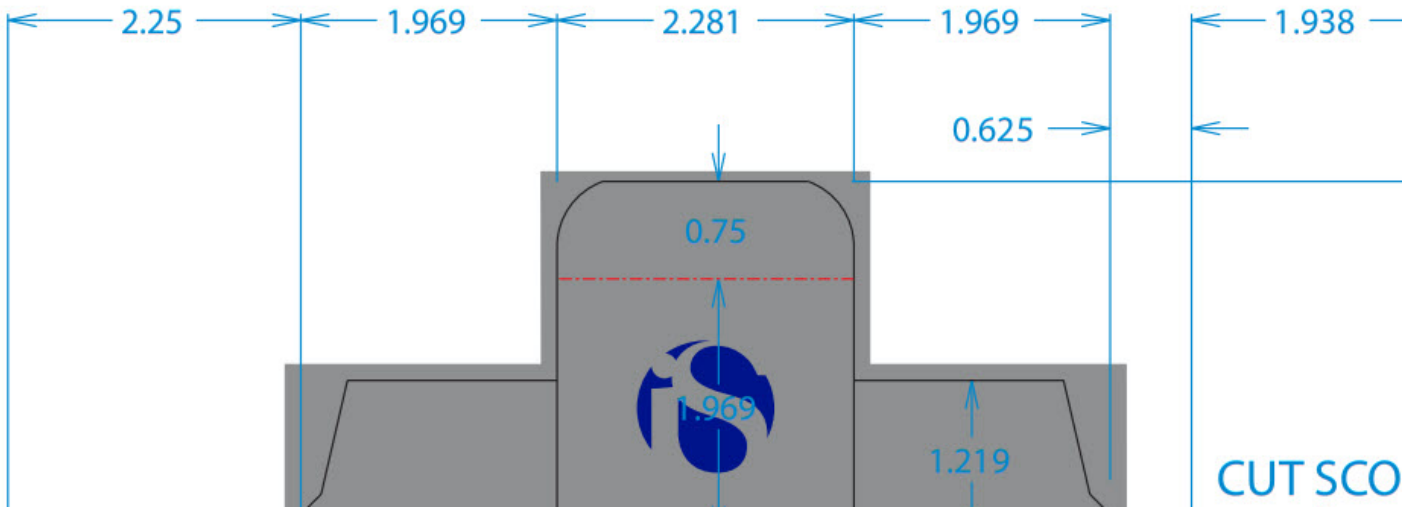

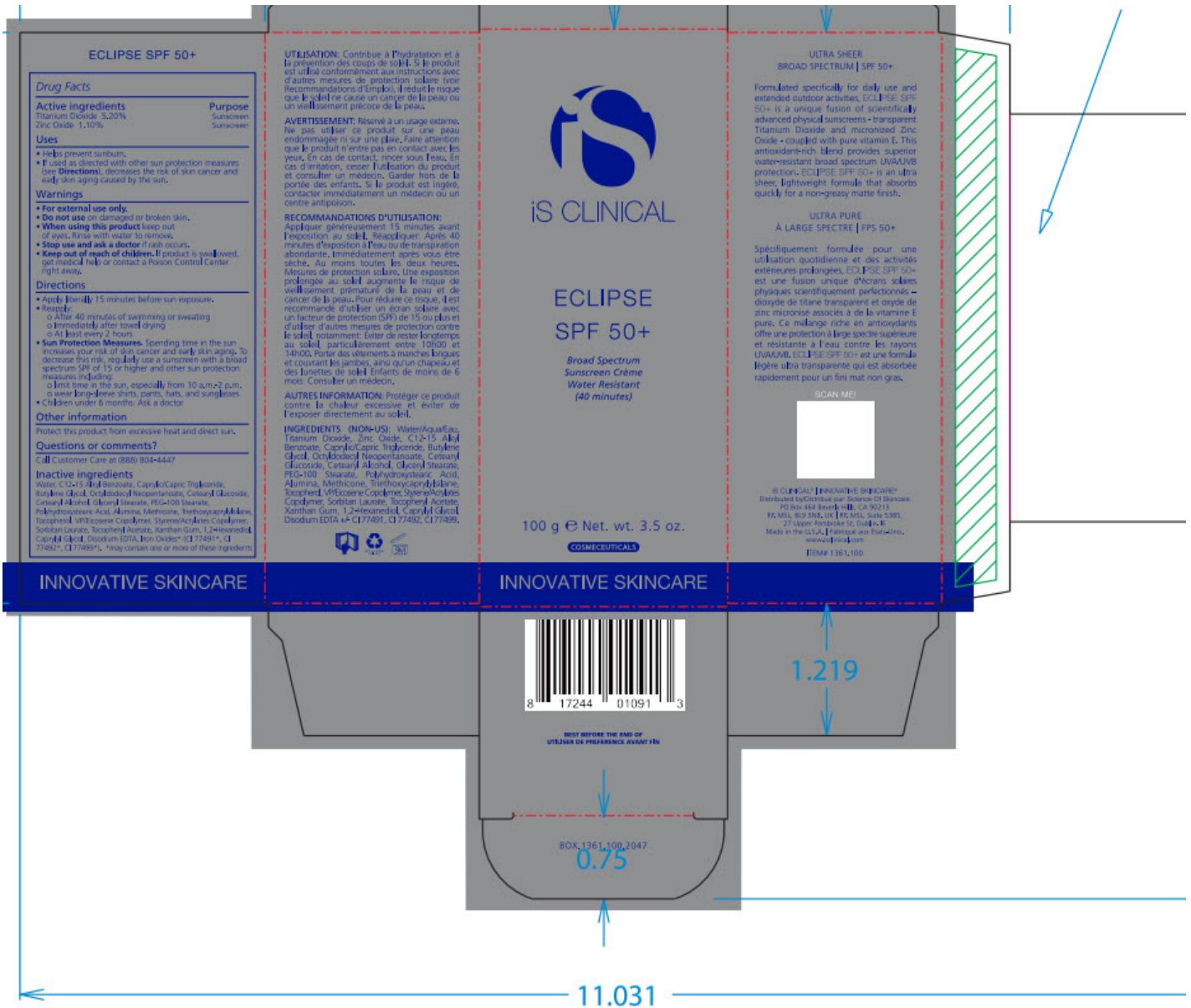

DESCRIPTION/VERSION#: Eclipse SPF 50 100g Box		
DESIGNER/ARTIST: Cynthia	REQUESTED BY: Marketing	DATE: 11/19/2020
ITEM #: BOX_1361_100_2047		<input type="checkbox"/> NEW PROJECT <input checked="" type="checkbox"/> UPDATE
CHANGES MADE: Box specs updated, QRCode added.		
<input checked="" type="checkbox"/> 4-COLOR PROCESS/CMYK	<input type="checkbox"/> PMS 877 C	<input type="checkbox"/> Custom Blue
<input checked="" type="checkbox"/> SPOT COLOR/PANTONE	<input type="checkbox"/> Black	<input type="checkbox"/> White
PAPER STOCK: 18 PT Silver Foil board	<input checked="" type="checkbox"/> GLOSS UV COATING	
OVERALL SIZE:	<input type="checkbox"/> DIE CUT	<input type="checkbox"/> FOLD LINE

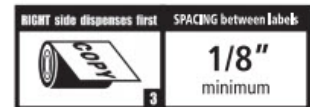
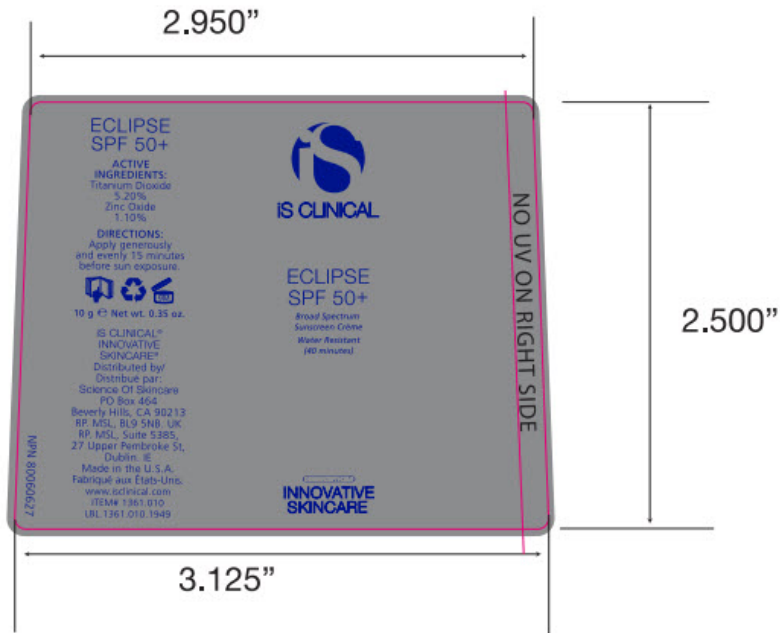

DESCRIPTION/VERSION#: Eclipse SPF 50+ Non Tint 10g Label			
DESIGNER/ARTIST: Cynthia		DATE: 1/17/2020	
ITEM #: LBL.1361.010.1949	REQUESTED BY: Operation	<input type="checkbox"/> NEW PROJECT	<input checked="" type="checkbox"/> UPDATE
CHANGES MADE: Set standards, shift front art to center align.			
<input type="checkbox"/> 4-COLOR PROCESS/CMYK	<input checked="" type="checkbox"/> SPOT COLOR/PANTONE		
PAPER STOCK: Silver BOPP	<input checked="" type="checkbox"/> UV GLOSS	<input type="checkbox"/> GLOSS	<input type="checkbox"/> MATTE
OVERALL SIZE:	— DIELINE		

ECLIPSE SPF 50 ALL SHADES

titanium dioxide, zinc oxide lotion

Product Information

Product Type	HUMAN OTC DRUG	Item Code (Source)	NDC:69219-102
Route of Administration	TOPICAL		

Active Ingredient/Active Moiety

Ingredient Name	Basis of Strength	Strength
TITANIUM DIOXIDE (UNII: 15FIX9V2JP) (TITANIUM DIOXIDE - UNII:15FIX9V2JP)	TITANIUM DIOXIDE	5.2 g in 100 g

ZINC OXIDE (UNII: SOI2LOH54Z) (ZINC CATION - UNII:13S1S8SF37)	ZINC CATION	1.1 g in 100 g
Inactive Ingredients		
Ingredient Name		Strength
1,2-HEXANEDIOL (UNII: TR046Y3K1G)		
ALUMINUM (UNII: CPD4NFA903)		
BUTYLENE GLYCOL (UNII: 3XUS85K0RA)		
ALKYL (C12-15) BENZOATE (UNII: A9EJ3J61HQ)		
MEDIUM-CHAIN TRIGLYCERIDES (UNII: C9H2L21V7U)		
CAPRYLYL GLYCOL (UNII: 00YIU5438U)		
CETOSTEARYL ALCOHOL (UNII: 2DMT128M1S)		
CETEARYL GLUCOSIDE (UNII: 09FUA47KNA)		
EDETATE DISODIUM (UNII: 7FLD91C86K)		
GLYCERYL MONOSTEARATE (UNII: 230OU9XXE4)		
OCTYLDODECYL NEOPENTANOATE (UNII: X8725R883T)		
PEG-100 STEARATE (UNII: YD01N1999R)		
POLYHYDROXYSTEARIC ACID (2300 MW) (UNII: YXH47AOU0F)		
SORBITAN MONOLAURATE (UNII: 6W9PS8B71J)		
STYRENE (UNII: 44LJ2U959V)		
TOCOPHEROL (UNII: R0ZB2556P8)		
.ALPHA.-TOCOPHEROL ACETATE (UNII: 9E8X80D2L0)		
TRIETHOXYCAPRYLYLSILANE (UNII: LDC331P08E)		
VINYLPYRROLIDONE/EICOSENE COPOLYMER (UNII: 035MV9S1C3)		
WATER (UNII: 059QF0KO0R)		
XANTHAN GUM (UNII: TTV12P4NEE)		
FERRIC OXIDE RED (UNII: 1K09F3G675)		
FERROSFERRIC OXIDE (UNII: XM0M87F357)		
FERRIC OXIDE YELLOW (UNII: EX438O2MRT)		

Packaging				
#	Item Code	Package Description	Marketing Start Date	Marketing End Date
1	NDC:69219-102-51	1 in 1 BOX	10/01/2014	
1	NDC:69219-102-13	90 g in 1 BOTTLE, PUMP; Type 0: Not a Combination Product		
2	NDC:69219-102-11	1 in 1 BOX	10/01/2014	
2	NDC:69219-102-01	100 g in 1 BOTTLE, PUMP; Type 0: Not a Combination Product		
3	NDC:69219-102-21	1 in 1 BAG	10/01/2014	
3	NDC:69219-102-02	10 g in 1 BOTTLE, PUMP; Type 0: Not a Combination Product		
4	NDC:69219-102-03	300 g in 1 BOTTLE, PUMP; Type 0: Not a Combination Product	10/01/2014	
5	NDC:69219-102-01	100 g in 1 BOTTLE, PUMP; Type 0: Not a Combination Product	10/01/2014	
6	NDC:69219-102-02	10 g in 1 BOTTLE, PUMP; Type 0: Not a Combination Product	10/01/2014	

7	NDC:69219-102-53	1 in 1 BOX	08/01/2023	
7		300 g in 1 BOTTLE, PUMP; Type 0: Not a Combination Product		

Marketing Information

Marketing Category	Application Number or Monograph Citation	Marketing Start Date	Marketing End Date
OTC Monograph Drug	M020	10/01/2014	

Labeler - SCIENCE OF SKINCARE LLC (006251958)

Revised: 12/2023

SCIENCE OF SKINCARE LLC