

**CEFAZOLIN SODIUM- cefazolin sodium solution**  
**B. Braun Medical Inc.**

-----

**HIGHLIGHTS OF PRESCRIBING INFORMATION**

**These highlights do not include all the information needed to use CEFAZOLIN FOR INJECTION AND DEXTROSE INJECTION safely and effectively. See full prescribing information for CEFAZOLIN FOR INJECTION AND DEXTROSE INJECTION.**

**CEFAZOLIN FOR INJECTION AND DEXTROSE INJECTION, for intravenous use**

**Initial U.S. Approval: 1973**

----- **RECENT MAJOR CHANGES** -----

- Indications and Usage, Perioperative Prophylaxis (1.9) 11/2020
- Dosage and Administration, Dosage for the Treatment of Infections (2.2) 11/2020
- Dosage and Administration, Dosage for Perioperative Prophylaxis (2.3) 11/2020
- Dosage and Administration, Dosage Recommendations in Adult and Pediatric Patients with Renal Impairment (2.4) 11/2020

----- **INDICATIONS AND USAGE** -----

Cefazolin for Injection and Dextrose Injection is a cephalosporin antibacterial indicated for:

- Treatment of the following infections caused by susceptible isolates of the designated microorganisms in adult and pediatric patients for whom appropriate dosing with this formulation can be achieved: (1)
  - Respiratory tract infections (1.1);
  - Urinary tract infections (1.2);
  - Skin and skin structure infections (1.3);
  - Biliary tract infections (1.4);
  - Bone and joint infections (1.5);
  - Genital infections (1.6);
  - Septicemia (1.7);
  - Endocarditis (1.8)
- Perioperative prophylaxis in adults and pediatric patients aged 10 to 17 years old for whom appropriate dosing with this formulation can be achieved (1.9)

To reduce the development of drug-resistant bacteria and maintain the effectiveness of Cefazolin for Injection and Dextrose Injection and other antibacterial drugs, Cefazolin for Injection and Dextrose Injection should be used only to treat or prevent infections that are proven or strongly suspected to be caused by bacteria. (1.10).

----- **DOSAGE AND ADMINISTRATION** -----

If a dose of Cefazolin for Injection and Dextrose Injection is required that does not equal 1 gram or 2 grams, this product is not recommended for use and an alternative formulation of cefazolin should be considered. (2.1)

For intravenous use only administered over approximately 30 minutes. (2.1)

**Table 1: Recommended Dosing Schedule in Adult Patients with CLcr Greater Than or Equal To 55 mL/min. (2.1, 2.2 and 2.3)**

Site and Type of Infection	Dose	Frequency
Moderate to severe infections	500 mg to 1 gram	every 6 to 8 hours
Mild infections caused by susceptible gram-positive cocci	250 mg to 500 mg	every 8 hours
Acute, uncomplicated urinary tract infections	1 gram	every 12 hours
Pneumococcal pneumonia	500 mg	every 12 hours
Severe, life-threatening infections (e.g., endocarditis, septicemia)*	1 gram to 1.5 grams	every 6 hours
	1 gram to 2 grams	½ to 1 hour prior to start of surgery
		during surgery for lengthy

Perioperative prophylaxis	500 mg to 1 g	during surgery for lengthy procedures
	500 mg to 1 g	every 6 to 8 hours for 24 hours postoperatively

\* In rare instances, doses of up to 12 grams of cefazolin per day have been used.

**Recommended Dosing Schedule in Pediatric Patients with CLcr Greater than or Equal to 70 mL/min. (2.1, 2.2, and 2.3)**

Site and Type of Infection	Dose	Frequency
Moderate to severe infections*	25 to 50 mg per kg	divided into 3 or 4 equal doses
Severe infections*	May increase to 100 mg per kg	divided into 3 or 4 equal doses
Perioperative prophylaxis (10 to 17 years old)	< 50 kg: 1 gram	½ to 1 hour prior to start of surgery
	≥ 50 kg: 2 grams	
	500 mg to 1 g	during surgery for lengthy procedures
	500 mg to 1 g	every 6 to 8 hours for 24 hours postoperatively

\* For the treatment indications (1.1 to 1.8)

- Dosage adjustment is required for adult patients with CLcr that is less than 55 mL/min and pediatric patients with CLcr that is less than 70 mL/min. (2.4 and 8.6)
- See full prescribing information for preparation and administration instructions. (2.5)

**DOSAGE FORMS AND STRENGTHS**

Dual-Chamber in single-dose Duplex® Container:

- 1 g Cefazolin for Injection USP and 50 mL 4% Dextrose Injection USP (3)
- 2 g Cefazolin for Injection USP and 50 mL 3% Dextrose Injection USP (3)

**CONTRAINDICATIONS**

- Hypersensitivity to cefazolin or other cephalosporin class antibacterial drugs, penicillins, or other beta-lactams (4.1)

**WARNINGS AND PRECAUTIONS**

- Hypersensitivity reactions: Cross-hypersensitivity may occur in up to 10% of patients with a history of penicillin allergy. If an allergic reaction occurs, discontinue the drug. (5.1)
- Clostridioides difficile-associated diarrhea (CDAD): May range from mild diarrhea to fatal colitis. Evaluate if diarrhea occurs. (5.3)

**ADVERSE REACTIONS**

- Adult and Pediatric Patients: Most common adverse reactions: gastrointestinal (nausea, vomiting, diarrhea), and allergic reactions (anaphylaxis, urticaria, skin rash). (6)
- Pediatric Patients with Perioperative Prophylaxis: The most frequently reported adverse reactions (incidence ≥ 5%) were nausea, infusion site pain, and headache.

**To report SUSPECTED ADVERSE REACTIONS, contact B. Braun Medical Inc. at 1-800-854-6851 or FDA at 1-800-FDA-1088 or [www.fda.gov/medwatch](http://www.fda.gov/medwatch). (6)**

**DRUG INTERACTIONS**

- Probenecid: The renal excretion of cefazolin is inhibited by probenecid. Co-administration of probenecid with cefazolin for injection is not recommended. (7)

**See 17 for PATIENT COUNSELING INFORMATION.**

**Revised: 7/2021**

## **FULL PRESCRIBING INFORMATION: CONTENTS\***

### **RECENT MAJOR CHANGES**

#### **1 INDICATIONS AND USAGE**

- 1.1 Respiratory Tract Infections
- 1.2 Urinary Tract Infections
- 1.3 Skin and Skin Structure Infections
- 1.4 Biliary Tract Infections
- 1.5 Bone and Joint Infections
- 1.6 Genital Infections
- 1.7 Septicemia
- 1.8 Endocarditis
- 1.9 Perioperative Prophylaxis
- 1.10 Usage

#### **2 DOSAGE AND ADMINISTRATION**

- 2.1 Important Administration Instructions
- 2.2 Dosage for the Treatment of Infections
- 2.3 Dosage for Perioperative Prophylaxis
- 2.4 Dosage Recommendations in Adult and Pediatric Patients with Renal Impairment
- 2.5 Preparation for Use of Cefazolin for Injection and Dextrose Injection in DUPLEX® Container

#### **3 DOSAGE FORMS AND STRENGTHS**

#### **4 CONTRAINDICATIONS**

- 4.1 Hypersensitivity to Cefazolin or the Cephalosporin Class of Antibacterial Drugs, Penicillins, or Other Beta-lactams

#### **5 WARNINGS AND PRECAUTIONS**

- 5.1 Hypersensitivity Reactions to Cefazolin, Cephalosporins, Penicillins, or Other Beta-lactams
- 5.2 Seizures in Patients with Renal Impairment
- 5.3 *Clostridioides difficile*-associated Diarrhea
- 5.4 Hypersensitivity to Dextrose-containing Products
- 5.5 Risk of Development of Drug-resistant Bacteria
- 5.6 Drug/Laboratory Test Interactions
- 5.7 Patients with Overt or Known Subclinical Diabetes Mellitus or Carbohydrate Intolerance

#### **6 ADVERSE REACTIONS**

- 6.1 Clinical Trials Experience
- 6.2 Postmarketing Experience
- 6.3 Cephalosporin-class Adverse Reactions

#### **7 DRUG INTERACTIONS**

#### **8 USE IN SPECIFIC POPULATIONS**

- 8.1 Pregnancy
- 8.2 Lactation
- 8.4 Pediatric Use
- 8.5 Geriatric Use
- 8.6 Patients with Renal Impairment

#### **10 OVERDOSAGE**

#### **11 DESCRIPTION**

#### **12 CLINICAL PHARMACOLOGY**

- 12.1 Mechanism of Action

12.2 Pharmacodynamics

12.3 Pharmacokinetics

12.4 Microbiology

## **13 NONCLINICAL TOXICOLOGY**

13.1 Carcinogenesis, Mutagenesis, Impairment of Fertility

## **15 REFERENCES**

## **16 HOW SUPPLIED/STORAGE AND HANDLING**

## **17 PATIENT COUNSELING INFORMATION**

\* Sections or subsections omitted from the full prescribing information are not listed.

---

## **FULL PRESCRIBING INFORMATION**

### **1 INDICATIONS AND USAGE**

#### **1.1 Respiratory Tract Infections**

Cefazolin for Injection and Dextrose Injection is indicated for the treatment of respiratory tract infections due to *Streptococcus pneumoniae*, *Staphylococcus aureus* and *Streptococcus pyogenes* in adults and pediatric patients for whom appropriate dosing with this formulation can be achieved [see *Dosage and Administration* (2.1, 2.2, 2.4, 2.5) and *Use in Specific Populations* (8.4)].

#### Limitations of Use

Injectable benzathine penicillin is considered the drug of choice in treatment and prevention of streptococcal infections, including the prophylaxis of rheumatic fever.

Cefazolin for Injection and Dextrose Injection is indicated for the eradication of streptococci from the nasopharynx; however, data establishing the efficacy of cefazolin in the subsequent prevention of rheumatic fever are not available.

#### **1.2 Urinary Tract Infections**

Cefazolin for Injection and Dextrose Injection is indicated for the treatment of urinary tract infections due to *Escherichia coli*, and *Proteus mirabilis* in adults and pediatric patients for whom appropriate dosing with this formulation can be achieved [see *Dosage and Administration* (2.1, 2.2, 2.4, 2.5) and *Use in Specific Populations* (8.4)].

#### **1.3 Skin and Skin Structure Infections**

Cefazolin for Injection and Dextrose Injection is indicated for the treatment of skin and skin structure infections due to *S. aureus*, *S. pyogenes*, and *Streptococcus agalactiae* in adults and pediatric patients for whom appropriate dosing with this formulation can be achieved [see *Dosage and Administration* (2.1, 2.2, 2.4, 2.5) and *Use in Specific Populations* (8.4)].

#### **1.4 Biliary Tract Infections**

Cefazolin for Injection and Dextrose Injection is indicated for the treatment of biliary

infections due to *E. coli*, various isolates of streptococci, *P. mirabilis*, and *S. aureus* in adults and pediatric patients for whom appropriate dosing with this formulation can be achieved [see *Dosage and Administration* (2.1, 2.2, 2.4, 2.5) and *Use in Specific Populations* (8.4)].

### **1.5 Bone and Joint Infections**

Cefazolin for Injection and Dextrose Injection is indicated for the treatment of bone and joint infections due to *S. aureus* in adults and pediatric patients for whom appropriate dosing with this formulation can be achieved [see *Dosage and Administration* (2.1, 2.2, 2.4, 2.5) and *Use in Specific Populations* (8.4)].

### **1.6 Genital Infections**

Cefazolin for Injection and Dextrose Injection is indicated for the treatment of genital infections due to *E. coli*, and *P. mirabilis* in adults and pediatric patients for whom appropriate dosing with this formulation can be achieved [see *Dosage and Administration* (2.1, 2.2, 2.4, 2.5) and *Use in Specific Populations* (8.4)].

### **1.7 Septicemia**

Cefazolin for Injection and Dextrose Injection is indicated for the treatment of septicemia due to *S. pneumoniae*, *S. aureus*, *P. mirabilis*, and *E. coli* in adults and pediatric patients for whom appropriate dosing with this formulation can be achieved [see *Dosage and Administration* (2.1, 2.2, 2.4, 2.5) and *Use in Specific Populations* (8.4)].

### **1.8 Endocarditis**

Cefazolin for Injection and Dextrose Injection is indicated for the treatment of endocarditis due to *S. aureus* and *S. pyogenes* in adults and pediatric patients for whom appropriate dosing with this formulation can be achieved [see *Dosage and Administration* (2.1, 2.2, 2.4, 2.5) and *Use in Specific Populations* (8.4)].

### **1.9 Perioperative Prophylaxis**

Cefazolin for Injection and Dextrose Injection is indicated for perioperative prophylaxis in adults and pediatric patients aged 10 to 17 years old for whom appropriate dosing with this formulation can be achieved [see *Dosage and Administration* (2.1, 2.3, 2.4, 2.5) and *Use in Specific Populations* (8.4)].

The perioperative use of Cefazolin for Injection and Dextrose Injection is indicated in adult and pediatric (aged 10 to 17 years old) surgical patients in whom infection at the operative site would present a serious risk (e.g., during open-heart surgery and prosthetic arthroplasty).

The prophylactic administration of Cefazolin for Injection and Dextrose Injection preoperatively, intraoperatively, and postoperatively may reduce the incidence of certain postoperative infections in patients undergoing surgical procedures which are classified as contaminated or potentially contaminated (e.g., vaginal hysterectomy, and cholecystectomy in high-risk patients such as those older than 70 years, with acute cholecystitis, obstructive jaundice, or common duct bile stones).

### **1.10 Usage**

To reduce the development of drug-resistant bacteria and maintain the effectiveness of Cefazolin for Injection and Dextrose Injection and other antibacterial drugs, Cefazolin for Injection and Dextrose Injection should be used only to treat or prevent infections that are proven or strongly suspected to be caused by susceptible bacteria. When culture and susceptibility information are available, they should be considered in selecting or modifying antibacterial therapy. In the absence of such data, local epidemiology and susceptibility patterns may contribute to the empiric selection of therapy.

## 2 DOSAGE AND ADMINISTRATION

### 2.1 Important Administration Instructions

If a dose of Cefazolin for Injection and Dextrose Injection is required that does not equal 1 gram or 2 grams, this product is not recommended for use and an alternative formulation of cefazolin should be considered.

Administer Cefazolin for Injection and Dextrose Injection intravenously over approximately 30 minutes.

### 2.2 Dosage for the Treatment of Infections

#### Dosage for the Treatment of Infections in Adults with Creatinine Clearance (CLcr) Equal to 55 mL/min or Greater

The recommended adult dosages for the treatment of infections [see *Indications and Usage (1.1 to 1.8)*] are outlined in Table 1 below. Administer Cefazolin for Injection and Dextrose Injection intravenously over approximately 30 minutes.

<b>Site and Type of Infection</b>	<b>Dose</b>	<b>Frequency</b>
Moderate to severe infections	500 mg to 1 gram	every 6 to 8 hours
Mild infections caused by susceptible gram-positive cocci	250 mg to 500 mg	every 8 hours
Acute, uncomplicated urinary tract infections	1 gram	every 12 hours
Pneumococcal pneumonia	500 mg	every 12 hours
Severe, life-threatening infections (e.g., endocarditis, septicemia) <sup>†</sup>	1 gram to 1.5 grams	every 6 hours

\* If a dose of Cefazolin for Injection and Dextrose Injection is required that does not equal 1 gram or 2 grams, this product is not recommended for use and an alternative formulation of cefazolin should be considered.

† In rare instances, doses of up to 12 grams of cefazolin per day have been used.

#### Dosage for the Treatment of Infections in Pediatric Patients with CLcr Equal to 70 mL/min or Greater

The recommended pediatric dosages for the treatment of infections [see *Indications and Usage (1.1 to 1.8)*] are outlined in Table 2 below. Administer Cefazolin for Injection and

Dextrose Injection intravenously over approximately 30 minutes.

If a dose of Cefazolin for Injection and Dextrose Injection is required that does not equal 1 gram or 2 grams, this product is not recommended for use and an alternative formulation of cefazolin should be considered [see *Use in Specific Populations (8.4)*].

Type of Severity	Recommended Total Daily Dosage
Mild to moderate infections	25 mg/kg to 50 mg/kg, divided into 3 or 4 equal doses
Severe infections	May increase to 100 mg/kg, divided into 3 or 4 equal doses

### 2.3 Dosage for Perioperative Prophylaxis

#### Dosage for Perioperative Prophylaxis in Adults with CLcr Equal to 55 mL/min or Greater

To prevent postoperative infection in contaminated or potentially contaminated surgery, recommended dosages are described in Table 3 below.

Dose administered ½ hour to 1 hour prior to the start of surgery	Additional dose during lengthy operative procedures (e.g., 2 hours or more)	Dose for 24 hours postoperatively
1 g 2 g	500 mg to 1 g	500 mg to 1 g every 6 hours to 8 hours

If a dose of Cefazolin for Injection and Dextrose Injection is required that does not equal 1 gram or 2 grams, this product is not recommended and an alternative formulation of cefazolin should be considered.

It is important that (i) the preoperative dose be given just prior (1/2 hour to 1 hour) to the start of surgery so that adequate antibacterial concentrations are present in the serum and tissues at the time of initial surgical incision; and (ii) cefazolin be administered, if necessary, at appropriate intervals during surgery to provide sufficient concentrations of the antibacterial drug at the anticipated moments of greatest exposure to infective organisms.

The perioperative prophylactic administration of cefazolin should usually be discontinued

within a 24-hour period after the surgical procedure. In surgery where the occurrence of infection may be particularly devastating (e.g., open-heart surgery and prosthetic arthroplasty), the prophylactic administration of cefazolin may be continued for 3 days to 5 days following the completion of surgery.

Dosage for Perioperative Prophylaxis in Pediatric Patients Aged 10 to 17 Years Old with CLcr 70 mL/min or Greater

To prevent postoperative infection in contaminated or potentially contaminated surgery, recommended doses are described in Table 4 below.

<b>Table 4: Recommended Dosage for Perioperative Prophylaxis in Pediatric Patients with CLcr 70 mL/min or greater Aged 10 to 17 years Old *</b>			
<b>Body weight (kg)</b>	<b>Dose administered <sup>1/2</sup> to 1 hour prior to the start of surgery</b>	<b>Additional dose during lengthy operative procedures (e.g., 2 hours or more)</b>	<b>Dose for 24 hours postoperatively</b>
Less than 50 kg	1 g	500 mg to 1 g	500 mg to 1 g every 6 hours to 8 hours
Greater than or equal to 50 kg	2 g		

\* If a dose of Cefazolin for Injection and Dextrose Injection is required that does not equal 1 gram or 2 grams, this product is not recommended for use and an alternative formulation of cefazolin should be considered.

It is important that (i) the preoperative dose be given just prior (1/2 hour to 1 hour) to the start of surgery so that adequate antibacterial concentrations are present in the serum and tissues at the time of initial surgical incision; and (ii) cefazolin be administered, if necessary, at appropriate intervals during surgery to provide sufficient concentrations of the antibacterial drug at the anticipated moments of greatest exposure to infective organisms.

The administration of Cefazolin for Injection and Dextrose Injection for perioperative prophylaxis should usually be discontinued within a 24-hour period after the surgical procedure. In surgery where the occurrence of infection may be particularly devastating the administration of Cefazolin for Injection and Dextrose Injection for perioperative prophylaxis may be continued for 3 days to 5 days following the completion of surgery.

**2.4 Dosage Recommendations in Adult and Pediatric Patients with Renal Impairment**

Dosage Recommendations in Adult Patients with CLcr less than 55 mL/min

The dosage recommendation for Cefazolin for Injection and Dextrose Injection in adult patients with renal impairment (CLcr less than 55 mL/min) is outlined in Table 5 below.

**Table 5: Dosage Recommendation for Adult Patients with CLcr less than 55 mL/min**



<b>Creatinine Clearance</b>	<b>Dose</b>	<b>Frequency</b>
35 to 54 mL/min	Recommended dose	every 8 hours or longer
11 to 34 mL/min	Half of recommended dose*	every 12 hours
10 mL/min or less	Half of recommended dose*	every 18 to 24 hours

\* If the recommended dose in adult patients with creatinine clearance equal to 35 mL/min or greater is 1 gram, then this product is not recommended for use in patients with creatinine clearance less than 35 mL/min and an alternative formulation of cefazolin should be considered.

### Dosage Recommendations in Pediatric Patients with CLcr less than 70 mL/min

The dosage recommendation for Cefazolin for Injection and Dextrose Injection in pediatric patients with renal impairment (CLcr less than 70 mL/min) is outlined in Table 6 below.

**Table 6: Recommended Dosage in Pediatric Patients with CLcr less than 70 mL/min**

<b>Creatinine Clearance</b>	<b>Recommended Dosage</b>
40 to 70 mL/min	60% of the normal daily dose given in equally divided doses every 12 hours
20 to 40 mL/min	25% of the normal daily dose given in equally divided doses every 12 hours
5 to 20 mL/min	10% of the normal daily dose every 24 hours

\*If a dose of Cefazolin for Injection and Dextrose Injection is required that does not equal 1 gram or 2 grams, this product is not recommended for use and an alternative formulation of cefazolin should be considered.

## **2.5 Preparation for Use of Cefazolin for Injection and Dextrose Injection in DUPLEX® Container**

This reconstituted solution of Cefazolin for Injection and Dextrose Injection is for intravenous use only.

Do **not** use plastic containers in series connections. Such use would result in air embolism due to residual air being drawn from the primary container before administration of the fluid from the secondary container is complete. If administration is controlled by a pumping device, care must be taken to discontinue pumping action before the container runs dry or air embolism may result.

Parenteral drug products should be inspected visually for particulate matter and discoloration prior to administration. Use only if solution is clear and container and seals are intact.

### DUPLEX® Container Storage

- To avoid inadvertent activation, the DUPLEX® Container should remain in the folded position until activation is intended.

### Patient Labeling and Drug Powder/Diluent Inspection

- Apply patient-specific label on foil side of container. Use care to avoid activation. Do not cover any portion of foil strip with patient label.
- Unlatch side tab and unfold DUPLEX® Container (see *Diagram 1*).

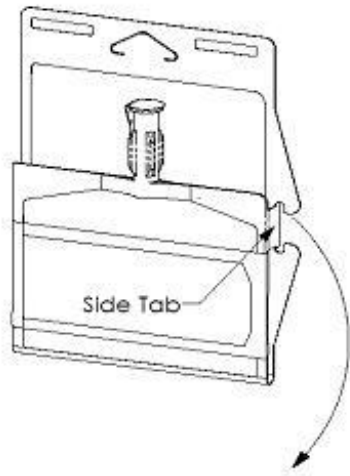

Diagram 1

- Visually inspect diluent chamber for particulate matter.
- Use only if container and seals are intact.
- To inspect the drug powder for foreign matter or discoloration, peel foil strip from drug chamber (see *Diagram 2*).

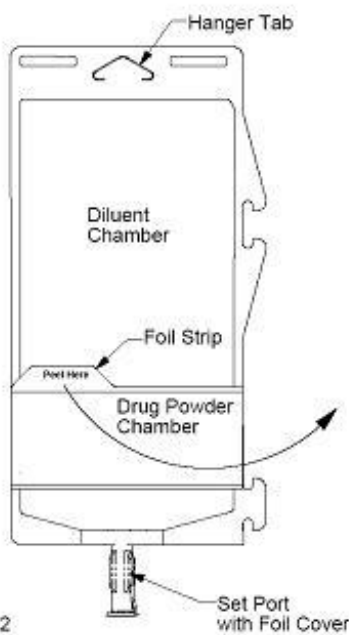

Diagram 2

- Protect from light after removal of foil strip.

Note: If foil strip is removed, the container should be re-folded and the side tab latched

until ready to activate. The product must then be used within 7 days, but not beyond the labeled expiration date.

### Reconstitution (Activation)

- Do not use directly after storage by refrigeration, allow the product to equilibrate to room temperature before patient use.
- Unfold the DUPLEX® Container and point the set port in a downward direction. Starting at the hanger tab end, fold the DUPLEX® Container just below the diluent meniscus trapping all air above the fold. To activate, squeeze the folded diluent chamber until the seal between the diluent and powder opens, releasing diluent into the drug powder chamber (see *Diagram 3*).

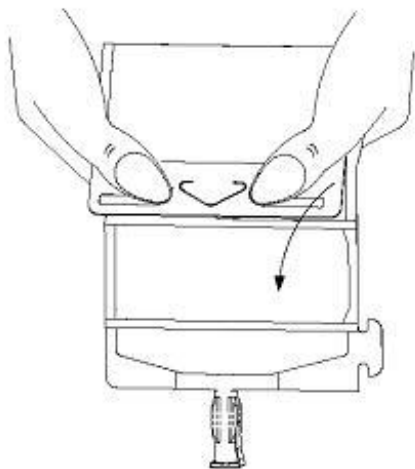

Diagram 3

- Agitate the liquid-powder mixture until the drug powder is completely dissolved.

Note: Following reconstitution (activation), product must be used within 24 hours if stored at room temperature or within 7 days if stored under refrigeration.

### Administration

- Visually inspect the reconstituted solution for particulate matter.
- Point the set port in a downwards direction. Starting at the hanger tab end, fold the DUPLEX® Container just below the solution meniscus trapping all air above the fold. Squeeze the folded DUPLEX® Container until the seal between reconstituted drug solution and set port opens, releasing liquid to set port (see *Diagram 4*).

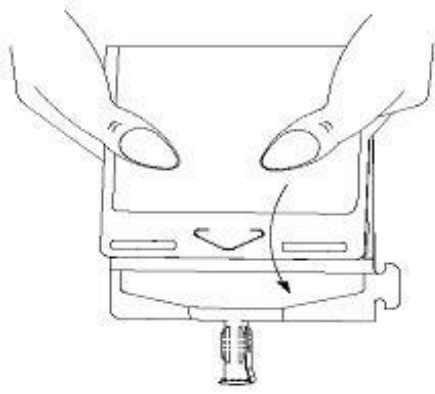

Diagram 4

- Prior to attaching the IV set, check for minute leaks by squeezing container firmly. If leaks are found, discard container and solution as sterility may be compromised.
- Using aseptic technique, peel foil cover from the set port and attach sterile administration set (see *Diagram 5*).

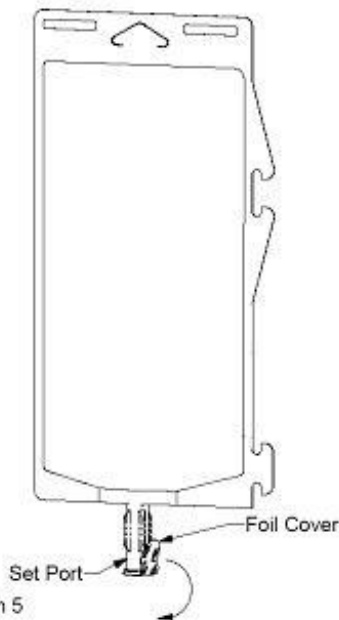

Diagram 5

- Refer to directions for use accompanying the administration set.

#### Important Administration Instructions

- Do not use in series connections.
- Do not introduce additives into the DUPLEX® Container.
- Administer Cefazolin for Injection and Dextrose Injection intravenously over approximately 30 minutes.

### **3 DOSAGE FORMS AND STRENGTHS**

Dual-chamber, single-dose packaged combination of Cefazolin Sodium USP (lyophilized) and sterile iso-osmotic diluent in the DUPLEX® sterile container consisting of :

- 1 g Cefazolin for Injection USP and 50 mL 4% Dextrose Injection USP
- 2 g Cefazolin for Injection USP and 50 mL 3% Dextrose Injection USP

## **4 CONTRAINDICATIONS**

### **4.1 Hypersensitivity to Cefazolin or the Cephalosporin Class of Antibacterial Drugs, Penicillins, or Other Beta-lactams**

Cefazolin for Injection and Dextrose Injection is contraindicated in patients who have a history of immediate hypersensitivity reactions (e.g., anaphylaxis, serious skin reactions) to cefazolin or the cephalosporin class of antibacterial drugs, penicillins, or other beta-lactams [see *Warnings and Precautions (5.1)*].

## **5 WARNINGS AND PRECAUTIONS**

### **5.1 Hypersensitivity Reactions to Cefazolin, Cephalosporins, Penicillins, or Other Beta-lactams**

Serious and occasionally fatal hypersensitivity (anaphylactic) reactions have been reported in patients receiving beta-lactam antibacterial drugs. Before therapy with Cefazolin for Injection and Dextrose Injection is instituted, careful inquiry should be made to determine whether the patient has had previous immediate hypersensitivity reactions to cefazolin, cephalosporins, penicillins, or carbapenems. Exercise caution if this product is to be given to penicillin-sensitive patients because cross-hypersensitivity among beta-lactam antibacterial drugs has been clearly documented and may occur in up to 10% of patients with a history of penicillin allergy. If an allergic reaction to Cefazolin for Injection and Dextrose Injection occurs, discontinue the drug.

### **5.2 Seizures in Patients with Renal Impairment**

Seizures may occur with the administration of Cefazolin for Injection and Dextrose Injection, particularly in patients with renal impairment when the dosage is not reduced appropriately. Discontinue Cefazolin for Injection and Dextrose Injection if seizures occur or make appropriate dosage adjustments in patients with renal impairment [see *Dosage and Administration (2.4)*]. Anticonvulsant therapy should be continued in patients with known seizure disorders.

### **5.3 *Clostridioides difficile*-associated Diarrhea**

*Clostridioides difficile*-associated diarrhea (CDAD) has been reported with use of nearly all antibacterial agents, including cefazolin, and may range in severity from mild diarrhea to fatal colitis. Treatment with antibacterial agents alters the normal flora of the colon leading to overgrowth of *C. difficile*.

*C. difficile* produces toxins A and B, which contribute to the development of CDAD. Hypertoxin-producing isolates of *C. difficile* cause increased morbidity and mortality, as these infections can be refractory to antimicrobial therapy and may require colectomy. CDAD must be considered in all patients who present with diarrhea following antibacterial drug use. Careful medical history is necessary since CDAD has been reported to occur

over two months after the administration of antibacterial agents.

If CDAD is suspected or confirmed, ongoing antibacterial drug use not directed against *C. difficile* may need to be discontinued. Appropriate fluid and electrolyte management, protein supplementation, antibacterial drug treatment of *C. difficile*, and surgical evaluation should be instituted as clinically indicated.

#### **5.4 Hypersensitivity to Dextrose-containing Products**

Hypersensitivity reactions, including anaphylaxis, have been reported with administration of dextrose-containing products. These reactions have been reported in patients receiving high concentrations of dextrose (i.e. 50% dextrose)<sup>1</sup>. The reactions have also been reported when corn-derived dextrose solutions were administered to patients with or without a history of hypersensitivity to corn products.<sup>2</sup>

#### **5.5 Risk of Development of Drug-resistant Bacteria**

Prescribing cefazolin for injection and dextrose injection in the absence of proven or strongly suspected bacterial infection or a prophylactic indication is unlikely to provide benefit to the patient and increases the risk of the development of drug-resistant bacteria.

As with other antimicrobials, prolonged use of Cefazolin for Injection and Dextrose Injection may result in overgrowth of nonsusceptible microorganisms. Repeated evaluation of the patient's condition is essential. Should superinfection occur during therapy, appropriate measures should be taken.

#### **5.6 Drug/Laboratory Test Interactions**

##### Urinary Glucose

The administration of cefazolin may result in a false-positive reaction with glucose in the urine when using glucose tests based on Benedict's copper reduction reaction that determine the amount of reducing substances like glucose in the urine. It is recommended that glucose tests based on enzymatic glucose oxidase be used.

##### Coombs' Test

Positive direct Coombs' tests have been reported during treatment with cefazolin. In hematologic studies or in transfusion cross-matching procedures when antiglobulin tests are performed on the minor side or in Coombs' testing of newborns whose mothers have received cephalosporin antibacterial drugs before parturition, it should be recognized that a positive Coombs' test may be due to the drug.

#### **5.7 Patients with Overt or Known Subclinical Diabetes Mellitus or Carbohydrate Intolerance**

As with other dextrose-containing solutions, Cefazolin for Injection and Dextrose Injection should be prescribed with caution in patients with overt or known subclinical diabetes mellitus or carbohydrate intolerance for any reason.

## **6 ADVERSE REACTIONS**

The following serious adverse reactions to Cefazolin for Injection and Dextrose Injection are described below and elsewhere in the labeling:

- Hypersensitivity reactions [see *Warnings and Precautions (5.1)*]
- Seizures in Patients with Renal Impairment [see *Warnings and Precautions (5.2)*]
- *Clostridioides difficile*-associated diarrhea [see *Warnings and Precautions (5.3)*]

## 6.1 Clinical Trials Experience

Because clinical trials are conducted under widely varying conditions, adverse reaction rates observed in the clinical trials of a drug cannot be directly compared to rates in the clinical trials of another drug and may not reflect the rates observed in practice.

The following adverse reactions were reported from clinical trials:

*Gastrointestinal:* Diarrhea, oral candidiasis (oral thrush), mouth ulcers, vomiting, nausea, stomach cramps, epigastric pain, heartburn, flatus, anorexia and pseudomembranous colitis. Onset of pseudomembranous colitis symptoms may occur during or after antibacterial treatment [see *Warnings and Precautions (5.3)*].

*Allergic:* Anaphylaxis, eosinophilia, urticaria, itching, drug fever, skin rash, Stevens-Johnson syndrome.

*Hematologic:* Neutropenia, leukopenia, thrombocytopenia, thrombocythemia.

*Hepatic:* Transient rise in SGOT, SGPT, and alkaline phosphatase levels has been observed. Reports of hepatitis have been received.

*Renal:* Reports of increased BUN and creatinine levels, as well as renal failure, have been received.

*Local Reactions:* Instances of phlebitis have been reported at site of injection. Some induration has occurred.

*Other Reactions:* Pruritus (including genital, vulvar and anal pruritus, genital moniliasis, and vaginitis). Dizziness, fainting, lightheadedness, confusion, weakness, tiredness, hypotension, somnolence and headache.

### Adverse Reactions in Pediatric Patients for Perioperative Prophylaxis

Two studies (Study 1: NCT 3231228 and Study 2: NCT 01904357) were conducted to assess the safety and pharmacokinetics of a single 30-minute infusion of either 1 gram or 2 grams (based on weight) of Cefazolin for Injection and Dextrose Injection for perioperative prophylaxis in pediatric patients.

Study 1 was a multicenter, open-label, non-comparative, parallel group study to evaluate the safety and pharmacokinetics of a single 30-minute infusion of either 1 gram or 2 grams (based on weight) of Cefazolin for Injection and Dextrose Injection for perioperative prophylaxis in 61 pediatric patients 10 to 17 years of age. Thirty-three subjects with a weight of at least 25 kg but less than 60 kg received a single dose of 1 gram of cefazolin and 28 subjects with a weight of at least 60 kg received a single dose of 2 grams of cefazolin. The mean age of the safety population was 14 years and ranged from 10 to 17 years. There were no adverse reactions leading to study discontinuation or deaths reported during the study. The most frequently reported adverse reactions were nausea (14.8%), infusion site pain (6.6%), and headache (4.9%).

Study 2 was a multicenter, non-comparative study that evaluated the safety and pharmacokinetics of a single 30-minute infusion of either 1 gram or 2 grams (based on weight) of Cefazolin for Injection and Dextrose Injection for perioperative prophylaxis in 12 pediatric patients 10 to 12 years of age. Subjects weighing at least 25 kg to less than 50 kg received a single dose of 1 gram of Cefazolin for Injection and Dextrose Injection and subjects weighing at least 50 kg to less than 85 kg received a single dose of 2 grams of Cefazolin for Injection and Dextrose Injection.

The safety findings in Study 2 in pediatric patients aged 10 to 12 years old were similar to those observed in adult patients and the pediatric patients aged 10 to 17 years old in Study 1.

## **6.2 Postmarketing Experience**

The following adverse reactions have been identified during post approval use of cefazolin. Because these reactions are reported voluntarily from a population of uncertain size, it is not always possible to reliably estimate their frequency or establish a causal relationship to drug exposure.

*Immune system disorders: Serum sickness-like reaction*

*Renal and urinary disorders: Acute tubulointerstitial nephritis (ATIN)*

*Skin and subcutaneous tissue disorders: Acute generalized exanthematous pustulosis (AGEP)*

## **6.3 Cephalosporin-class Adverse Reactions**

In addition to the adverse reactions listed above that have been observed in patients treated with cefazolin, the following adverse reactions and altered laboratory tests have been reported for cephalosporin-class antibacterials:

Stevens-Johnson syndrome, erythema multiforme, toxic epidermal necrolysis, renal impairment, toxic nephropathy, aplastic anemia, hemolytic anemia, hemorrhage, hepatic impairment including cholestasis, and pancytopenia.

## **7 DRUG INTERACTIONS**

The renal excretion of cefazolin is inhibited by probenecid. Co-administration of probenecid with Cefazolin for Injection and Dextrose Injection is not recommended.

## **8 USE IN SPECIFIC POPULATIONS**

### **8.1 Pregnancy**

#### Risk Summary

Available data from published prospective cohort studies, case series and case reports over several decades with cephalosporin use, including cefazolin, in pregnant women have not established a drug-associated risk of major birth defects, miscarriage, or adverse maternal or fetal outcomes. Cefazolin crosses the placenta.

Animal reproduction studies with rats, mice and rabbits administered cefazolin during



organogenesis at doses 1 to 3 times the maximum recommended human dose (MRHD) did not demonstrate adverse developmental outcomes. In rats subcutaneously administered cefazolin prior to delivery and throughout lactation, there were no adverse effects on offspring at a dose approximately 2 times the MRHD (*see Data*).

The estimated background risk of major birth defects and miscarriage for the indicated population is unknown. All pregnancies have a background risk of birth defect, loss, or other adverse outcomes. In the U.S. general population, the estimated background risk of major birth defects and miscarriage in clinically recognized pregnancies is 2% to 4% and 15% to 20%, respectively.

## Data

### *Human Data*

While available studies cannot definitively establish the absence of risk, published data from case-control studies and case reports over several decades have not identified an association with cephalosporin use during pregnancy and major birth defects, miscarriage, or other adverse maternal or fetal outcomes. Available studies have methodologic limitations, including small sample size, retrospective data collection, and inconsistent comparator groups.

### *Animal Data*

Reproduction studies have been performed in rats, mice and rabbits administered cefazolin during organogenesis at doses of 2000, 4000 and 240 mg/kg/day (approximately 1 to 3 times the maximum recommended human dose on a body surface area comparison). There was no evidence of any adverse effects on embryofetal development due to cefazolin. In a peri-postnatal study in rats, cefazolin administered subcutaneously up to 1200 mg/kg/day (approximately 2 times the MRHD based on body surface area comparison) to pregnant dams prior to delivery and through lactation caused no adverse effects on offspring.

## **8.2 Lactation**

Data from published literature report that cefazolin is present in human milk, but is not expected to accumulate in a breastfed infant. There are no data on the effects of cefazolin on the breastfed child or on milk production.

The developmental and health benefits of breastfeeding should be considered along with the mother's clinical need for Cefazolin for Injection and Dextrose Injection and any potential adverse effects on the breastfed child from Cefazolin for Injection and Dextrose Injection or from the mother's underlying condition.

## **8.4 Pediatric Use**

Cefazolin for Injection and Dextrose Injection is indicated for the treatment of respiratory tract infections, urinary tract infections, skin and skin structure infections, biliary tract infections, bone and joint infections, genital infections, septicemia, and endocarditis in pediatric patients for whom appropriate dosing with this formulation can be achieved, and for perioperative prophylaxis in pediatric patients aged 10 to 17 years old [*see Indications and Usage (1.1 to 1.9)*].

Safety and effectiveness of Cefazolin for Injection and Dextrose Injection in premature

infants and neonates have not been established and is not recommended for use in this age group of pediatric patients. Dosing for cefazolin in pediatric patients younger than one month old has not been established.

Because of the limitations of the available strengths and administration requirements (i.e., administration of fractional doses is not recommended) of Cefazolin for Injection and Dextrose Injection, and to avoid unintentional overdose, this product is not recommended for use if a dose of Cefazolin for Injection and Dextrose Injection that does not equal 1 gram or 2 grams is required and an alternative formulation of cefazolin should be considered [see *Dosage and Administration (2.2, 2.3, 2.4 and 2.5)*].

The safety and effectiveness of Cefazolin for Injection and Dextrose Injection for perioperative prophylaxis have been established in pediatric patients aged 10 to 17 years old. Use of Cefazolin for Injection and Dextrose Injection in these age groups is supported by evidence from adults with additional safety and pharmacokinetic data in pediatric patients aged 10 to 17 years old. Safety and pharmacokinetics were evaluated in two multicenter, non-comparative studies (Study 1 and Study 2). These studies were conducted to assess the safety and pharmacokinetics of a single 30-minute infusion of either 1 gram or 2 grams (based on weight) of Cefazolin for Injection and Dextrose Injection for perioperative prophylaxis in pediatric patients. Study 1 evaluated the safety and pharmacokinetics of 1 g of Cefazolin for Injection and Dextrose Injection in pediatric patients aged 10 to 17 years old scheduled for surgery with a weight of at least 25 kg but less than 60 kg and, 2 g in pediatric patients with a weight of at least 60 kg. Study 2 evaluated 1 g of Cefazolin for Injection and Dextrose Injection in pediatric patients aged 10 to 12 years old scheduled for surgery with a weight of at least 25 kg but less than 50 kg and, 2 g in pediatric patients with a weight of at least 50 kg to less than 85 kg [see *Dosage and Administration (2.3)*, *Adverse Reactions (6.1)* and *Clinical Pharmacology (12.3)*].

The safety and effectiveness of Cefazolin for Injection and Dextrose Injection for perioperative prophylaxis have not been established in pediatric patients younger than 10 years old.

## **8.5 Geriatric Use**

Of the 920 subjects who received cefazolin in clinical studies, 313 (34%) were 65 years and over, while 138 (15%) were 75 years and over. No overall differences in safety or effectiveness were observed between these subjects and younger subjects. Other reported clinical experience has not identified differences in responses between the elderly and younger patients, but greater sensitivity of some older individuals cannot be ruled out.

This drug is known to be substantially excreted by the kidney, and the risk of toxic reactions to this drug may be greater in patients with impaired renal function. Because elderly patients are more likely to have decreased renal function, care should be taken in dose selection, and it may be useful to monitor renal function [see *Dosage and Administration (2.4)* and *Warnings and Precautions (5.2)*].

## **8.6 Patients with Renal Impairment**

When Cefazolin for Injection and Dextrose Injection is administered to adult and pediatric patients with low urinary output because of impaired renal function (creatinine clearance less than 55 mL/min and 70 mL/min for adults and pediatric patients, respectively), lower

daily dosage is required [see *Dosage and Administration (2.4)* and *Warnings and Precautions (5.2)*].

## 10 OVERDOSAGE

Accidental overdose resulting in seizures may occur in patients with renal impairment who receive doses greater than the recommended dosage of Cefazolin for Injection and Dextrose Injection [see *Warnings and Precautions (5.2)*]. If seizures associated with accidental overdose occur, discontinue Cefazolin for Injection and Dextrose Injection and give supportive treatment.

## 11 DESCRIPTION

Cefazolin for Injection USP and Dextrose Injection USP is a sterile, nonpyrogenic, single-dose, packaged combination of Cefazolin Sodium USP (lyophilized) and sterile iso-osmotic diluent in the DUPLEX® sterile container. The DUPLEX® Container is a flexible dual chamber container.

After reconstitution the approximate osmolality for Cefazolin for Injection USP and Dextrose Injection USP is 290 mOsmol/kg.

The drug chamber is filled with sterile lyophilized Cefazolin Sodium USP, a semi-synthetic cephalosporin and has the following IUPAC nomenclature: Sodium (6*R*,7*R*)-3-[[[(5-methyl-1,3,4-thiadiazol-2-yl)thio]methyl]-8-oxo-7-[2-(1*H*-tetrazol-1-yl)acetamido]-5-thia-1-azabicyclo[4.2.0]oct-2-ene-2-carboxylate. Its empirical formula is C<sub>14</sub>H<sub>13</sub>N<sub>8</sub>NaO<sub>4</sub>S<sub>3</sub> and its molecular weight is 476.48.

Cefazolin Sodium USP has the following structural formula:

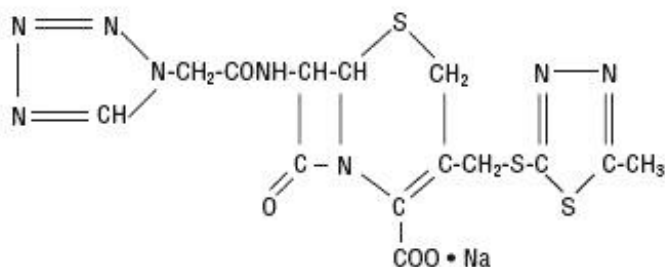

The sodium content is 48 mg/g of cefazolin sodium.

The diluent chamber contains Dextrose Injection USP, an iso-osmotic diluent using Hydrus Dextrose USP in Water for Injection USP. Dextrose Injection USP is sterile, nonpyrogenic, and contains no bacteriostatic or antimicrobial agents. Its empirical formula is C<sub>6</sub>H<sub>12</sub>O<sub>6</sub>•H<sub>2</sub>O and its molecular weight is 198.17.

Hydrus Dextrose USP has the following structural (molecular) formula:

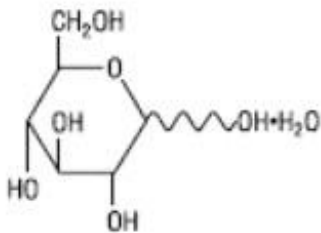

Cefazolin Sodium USP is supplied as a lyophilized form equivalent to either 1 g or 2 g of cefazolin. Dextrose hydrous USP has been added to the diluent to adjust osmolality (approximately 2 g [4.0% w/v] and 1.5 g [3.0% w/v] for the 1 g and 2 g dosages, respectively).

After removing the peelable foil strip, activating the seals, and thoroughly mixing, the reconstituted drug product is intended for single intravenous use.

Reconstituted solutions of Cefazolin for Injection and Dextrose Injection range in color from pale yellow to amber.

Not made with natural rubber latex, PVC or DEHP.

The DUPLEX® dual chamber container is made from a specially formulated material. The product (diluent and drug) contact layer is a mixture of thermoplastic rubber and a polypropylene ethylene copolymer that contains no plasticizers. The safety of the container system is supported by USP biological evaluation procedures.

## 12 CLINICAL PHARMACOLOGY

### 12.1 Mechanism of Action

Cefazolin is an antibacterial drug [see *Microbiology (12.4)*].

### 12.2 Pharmacodynamics

The pharmacokinetic/pharmacodynamic relationship for cefazolin has not been evaluated in patients.

### 12.3 Pharmacokinetics

Studies have shown that following intravenous administration of cefazolin to normal volunteers, mean serum concentrations peaked at approximately 185 mcg/mL and were approximately 4 mcg/mL at 8 hours for a 1 gram dose.

The serum half-life for cefazolin is approximately 1.8 hours following IV administration.

In a study of constant intravenous infusion with dosages of 3.5 mg/kg for 1 hour (approximately 250 mg) and 1.5 mg/kg the next 2 hours (approximately 100 mg) in healthy volunteers, cefazolin serum concentrations at the third hour were approximately 28 mcg/mL.

Plasma pharmacokinetic parameters of cefazolin in healthy volunteers (N=12) following a single 15-minute IV infusion of 2 grams of Cefazolin for Injection and Dextrose Injection are summarized in Table 7.

**Table 7: Mean (Standard Deviation) Plasma Pharmacokinetic Parameters of Cefazolin in Healthy Volunteers**

	N	C <sub>max</sub> (mcg/mL)	T <sub>max</sub> <sup>*</sup> (h)	AUC <sub>0-inf</sub> (mcg*h/mL)	t <sub>1/2</sub> (h)	CL (L/h)	V <sub>z</sub> (L)
Single 2 grams Dose as a 15-Minute IV Infusion	12	280.9 (45.9)	0.25 (0.25-0.33)	509.9 (89.3)	2.01 (0.28)	4.03 (0.68)	11.50 (1.53)

\* T<sub>max</sub> reported as median (range)

N= number of subjects observed; C<sub>max</sub> = maximum plasma concentration; T<sub>max</sub> = time to maximum plasma concentration; AUC<sub>0-inf</sub> = area under the plasma concentration-time curve extrapolated to infinity; t<sub>1/2</sub> = apparent plasma terminal elimination half-life; CL = total clearance; V<sub>z</sub> = volume of distribution

Studies in patients hospitalized with infections indicate that cefazolin mean peak serum concentrations were approximately equivalent to those seen in healthy volunteers.

Bile concentrations in patients without obstructive biliary disease can reach or exceed serum concentrations by up to five times; however, in patients with obstructive biliary disease, bile concentrations of cefazolin are considerably lower than serum concentrations (less than 1.0 mcg/mL).

In synovial fluid, the cefazolin concentration becomes comparable to that reached in serum at about 4 hours after drug administration.

Studies of cord blood show prompt transfer of cefazolin across the placenta. Cefazolin is present in very low concentrations in the milk of nursing mothers.

Cefazolin is excreted unchanged in the urine. In the first 6 hours, approximately 60% of the drug is excreted in the urine and this increases to 70% to 80% within 24 hours.

### Specific Populations

#### *Pediatric Patients for Perioperative Prophylaxis*

A simulation based on pharmacokinetic data from healthy adults (n=24), pediatric patients aged 10 to 17 years (n=26: Study 1 [see Adverse Reactions (6.1)]), and pediatric patients aged 10 to 12 years (n=12: Study 2 [see Adverse Reactions (6.1)]) indicate that the administration of a 1 gram cefazolin dose for pediatric patients weighing less than 50 kg and a 2 grams cefazolin dose for those weighing 50 kg or greater will provide comparable exposures between pediatric patients aged 10 to 17 years and healthy adults receiving 2 grams Cefazolin for Injection and Dextrose Injection [see Dosage and Administration (2.2 and 2.3) and Use in Specific Populations (8.4)].

## **12.4 Microbiology**

### Mechanism of Action

Cefazolin is a bactericidal agent that acts by inhibition of bacterial cell wall synthesis.

### Resistance

Predominant mechanisms of bacterial resistance to cephalosporins include the presence of extended-spectrum beta-lactamases and enzymatic hydrolysis.

### Antimicrobial Activity

Cefazolin has been shown to be active against most isolates of the following microorganisms, both in vitro and in clinical infections [see *Indications and Usage (1)*].

- Gram-positive bacteria
  - *Staphylococcus aureus*
  - *Staphylococcus epidermidis*
  - *Streptococcus agalactiae*
  - *Streptococcus pneumoniae*
  - *Streptococcus pyogenes*

Methicillin-resistant staphylococci are uniformly resistant to cefazolin.

- Gram-negative bacteria
  - *Escherichia coli*
  - *Proteus mirabilis*

Most isolates of indole positive *Proteus* (*Proteus vulgaris*), *Enterobacter* spp., *Morganella morganii*, *Providencia rettgeri*, *Serratia* spp., and *Pseudomonas* spp. are resistant to cefazolin.

### Susceptibility Testing

For specific information regarding susceptibility test interpretive criteria, and associated test methods and quality control standards recognized by FDA for this drug, please see: <http://www.fda.gov/STIC>.

## **13 NONCLINICAL TOXICOLOGY**

### **13.1 Carcinogenesis, Mutagenesis, Impairment of Fertility**

#### Carcinogenicity and Mutagenesis

Mutagenicity studies and long-term studies in animals to determine the carcinogenic potential of Cefazolin for Injection and Dextrose Injection have not been performed.

#### Impairment of Fertility

Fertility studies conducted in rats subcutaneously administered cefazolin at doses of 2000 mg/kg/day (approximately 3 times the maximum recommended human dose based on body surface area comparison) showed no impairment of mating and fertility.

## **15 REFERENCES**

1. Czarny D, Prichard PJ, Fennessy M, Lewis S. Anaphylactoid reaction to 50% solution of dextrose. *Med J Aust* 1980;2:255-258.
2. Guharoy, SR, Barajas M. Probably Anaphylactic Reaction to Corn-Derived Dextrose Solution. *Vet Hum Toxicol* 1991;33:609-610.

## 16 HOW SUPPLIED/STORAGE AND HANDLING

Cefazolin for Injection USP and Dextrose Injection USP in the single-dose DUPLEX® Container is a flexible dual chamber container supplied in two concentrations. After reconstitution, the concentrations are equivalent to 1 g and 2 g cefazolin. The diluent chamber contains approximately 50 mL of Dextrose Injection USP. Dextrose Injection USP has been adjusted to 4.0% and 3.0% for the 1 g and 2 g doses, respectively, such that the reconstituted solution is iso-osmotic.

Cefazolin for Injection USP and Dextrose Injection USP is supplied sterile and nonpyrogenic in the DUPLEX® Container packaged 24 units per case.

NDC	REF	Dose	Volume
0264-3103-11	3103-11	1 g	50 mL
0264-3105-11	3105-11	2 g	50 mL

Store the unactivated unit at 20-25°C (68-77°F). Excursions permitted to 15-30°C (59-86°F). [See USP Controlled Room Temperature.] Do not freeze.

As with other cephalosporins, reconstituted Cefazolin for Injection USP and Dextrose Injection USP tends to darken depending on storage conditions, within the stated recommendations. However, product potency is not adversely affected.

Use only if prepared solution is clear and free from particulate matter.

## 17 PATIENT COUNSELING INFORMATION

### Serious Allergic Reactions

Advise patients that allergic reactions, including serious allergic reactions could occur and that serious reactions require immediate treatment and discontinuation of Cefazolin for Injection and Dextrose Injection. Patients should report to their health care provider any previous allergic reactions to cefazolin, cephalosporins, penicillins, or other similar antibacterials.

### Seizures

Advise patients that seizures could occur with Cefazolin for Injection and Dextrose Injection. Instruct patients to inform a healthcare provider at once of any signs and symptoms of seizures, for immediate treatment, dosage adjustment, or discontinuation of Cefazolin for Injection and Dextrose Injection.

### Diarrhea

Advise patients that diarrhea is a common problem caused by antibacterials, which usually ends when the antibacterial is discontinued. Sometimes after starting treatment with antibacterials, patients can develop watery and bloody stools (with or without stomach cramps and fever) even as late as two or more months after having taken the last dose of the antibacterials. If this occurs, patients should contact a physician as soon as possible.

## Antibacterial Resistance

Patients should be counseled that antibacterial drugs, including Cefazolin for Injection and Dextrose Injection should only be used to treat bacterial infections. They do not treat viral infections (e.g., the common cold). When Cefazolin for Injection and Dextrose Injection is prescribed to treat a bacterial infection, patients should be told that although it is common to feel better early in the course of therapy, the medication should be taken exactly as directed. Skipping doses or not completing the full course of therapy may (1) decrease the effectiveness of the immediate treatment and (2) increase the likelihood that bacteria will develop resistance and will not be treatable by Cefazolin for Injection and Dextrose Injection or other antibacterial drugs in the future.

DUPLEX is a registered trademark of B. Braun Medical Inc.

ATCC is a registered trademark of the American Type Culture Collection.

### **B. Braun Medical Inc.**

Bethlehem, PA 18018-3524 USA

1-800-227-2862

Prepared in USA. API from USA and Italy.

Y36-003-047 LD-105-10

### **PRINCIPAL DISPLAY PANEL - 1g Cefazolin**

#### **Cefazolin for Injection USP and Dextrose Injection USP**

**1g\***

REF 3103-11

NDC 0264-3103-11

**DUPLEX®** CONTAINER

**50 mL**

**Use only after mixing contents of both chambers.**

**For IV Use Only    Iso-osmotic    Single Dose    Sterile/Nonpyrogenic**

\* Contains Cefazolin Sodium USP equivalent to 1 g cefazolin.

**Reconstitution:** Hold container with set port in a downward direction and fold the diluent chamber just below the solution meniscus. To activate seal, squeeze folded diluent chamber until seal between diluent and drug chamber opens, releasing diluent into drug chamber. Agitate the reconstituted solution until the drug powder is completely dissolved. Fold the container a second time and squeeze until seal between drug chamber and set port opens.

After reconstitution each 50 mL single dose unit contains: Cefazolin for Injection USP (equivalent to 1 g cefazolin) with approx. 2.0 g (4.0% w/v) Hydrous Dextrose USP in Water for Injection USP. Sodium content is 48 mg/g of cefazolin sodium.

Approximate osmolality: 290 mOsmol/kg

**Prior to Reconstitution:** Store at 20-25°C (68-77°F). Excursions permitted to 15-30°C (59-86°F). [See USP Controlled Room Temperature.] Use only if container and



seals are intact. Do not peel foil strip until ready for use. After foil strip removal, product must be used within 7 days, but not beyond the labeled expiration date. Protect from light after removal of foil strip.

**After Reconstitution:** Use only if prepared solution is clear and free from particulate matter. Use within 24 hours if stored at room temperature or within 7 days if stored under refrigeration. Do not use in a series connection. Do not introduce additives into this container. Prior to administration check for minute leaks by squeezing container firmly. If leaks are found, discard container and solution as sterility may be impaired. Do not freeze.

**Not made with natural rubber latex, PVC or DEHP.**

**B. Braun Medical Inc.**

Bethlehem, PA 18018-3524

Rx only

Prepared in USA. API from USA and Italy.

LD-201-7

Y37-002-541

EXP

LOT

**PEEL HERE**

**Drug Chamber**

Discard unit if foil strip is damaged. Peel foil strip only when ready for use. Visually inspect drug prior to reconstitution.

See package insert for complete directions for reconstitution and administration.

LD-336-1 X27-001-485

# Cefazolin for Injection USP and Dextrose Injection USP

# 1g\*

REF 3103-11

NDC 0264-3103-11

DUPLEX® CONTAINER

50 mL

Use only after mixing contents of both chambers.

For IV Use Only      Iso-osmotic      Single Dose      Sterile/Nonpyrogenic

\* Contains Cefazolin Sodium USP equivalent to 1 g cefazolin.

**Reconstitution:** Hold container with set port in a downward direction and fold the diluent chamber just below the solution meniscus. To activate seal, squeeze folded diluent chamber until seal between diluent and drug chamber opens, releasing diluent into drug chamber. Agitate the reconstituted solution until the drug powder is completely dissolved. Fold the container a second time and squeeze until seal between drug chamber and set port opens.

After reconstitution each 50 mL single dose unit contains: Cefazolin for Injection USP (equivalent to 1 g cefazolin) with approx. 2.0 g (4.0% w/v) Hydrous Dextrose USP in Water for Injection USP. Sodium content is 48 mg/g of cefazolin sodium. Approximate osmolality: 290 mOsmol/kg

**Prior to Reconstitution:** Store at 20-25°C (68-77°F). Excursions permitted to 15-30°C (59-86°F). [See USP Controlled Room Temperature.] Use only if container and seals are intact. Do not peel foil strip until ready for use. After foil strip removal, product must be used within 7 days, but not beyond the labeled expiration date. Protect from light after removal of foil strip.

**After Reconstitution:** Use only if prepared solution is clear and free from particulate matter. Use within 24 hours if stored at room temperature or within 7 days if stored under refrigeration. Do not use in a series connection. Do not introduce additives into this container. Prior to administration check for minute leaks by squeezing container firmly. If leaks are found, discard container and solution as sterility may be impaired. Do not freeze.

Not made with natural rubber latex, PVC or DEHP.

Rx only

**B | BRAUN** B. Braun Medical Inc.  
Bethlehem, PA 18018-3524

LD-201-7  
Y37-002-541

EXP

LOT



NDC No. (01)10302643103115

Prepared in USA. API from USA and Italy.

PEEL HERE



## Drug Chamber

Discard unit if foil strip is damaged. Peel foil strip only when ready for use. Visually inspect drug prior to reconstitution.

See package insert for complete directions for reconstitution and administration.

LD-336-1 X27-001-485

### **PRINCIPAL DISPLAY PANEL - 2g Cefazolin**

#### **Cefazolin for Injection USP and Dextrose Injection USP**

**2g\***

REF 3105-11

NDC 0264-3105-11

**DUPLEX® CONTAINER**

**50 mL**

**Use only after mixing contents of both chambers.**

**For IV Use Only    Iso-osmotic    Single Dose    Sterile/Nonpyrogenic**

\* Contains Cefazolin Sodium USP equivalent to 2 g cefazolin.

**Reconstitution:** Hold container with set port in a downward direction and fold the diluent chamber just below the solution meniscus. To activate seal, squeeze folded diluent chamber until seal between diluent and drug chamber opens, releasing diluent into drug chamber. Agitate the reconstituted solution until the drug powder is completely dissolved. Fold the container a second time and squeeze until seal between drug chamber and set port opens.

After reconstitution each 50 mL single dose unit contains: Cefazolin for Injection USP (equivalent to 2 g cefazolin) with approx. 1.5 g (3.0% w/v) Hydrous Dextrose USP in Water for Injection USP. Sodium content is 48 mg/g of cefazolin sodium. Approximate osmolality: 290 mOsmol/kg

**Prior to Reconstitution:** Store at 20-25°C (68-77°F). Excursions permitted to 15-30°C (59-86°F). [See USP Controlled Room Temperature.] Use only if container and seals are intact. Do not peel foil strip until ready for use. After foil strip removal, product must be used within 7 days, but not beyond the labeled expiration date. Protect from light after removal of foil strip.

**After Reconstitution:** Use only if prepared solution is clear and free from particulate matter. Use within 24 hours if stored at room temperature or within 7 days if stored under refrigeration. Do not use in a series connection. Do not introduce additives into this container. Prior to administration check for minute leaks by squeezing container firmly. If leaks are found, discard container and solution as sterility may be impaired. Do not freeze.

**Not made with natural rubber latex, PVC or DEHP.**

**B. Braun Medical Inc.**

Bethlehem, PA 18018-3524

Rx only

Prepared in USA. API from USA and Italy.

LD-200-4

Y37-002-542

EXP

LOT

**PEEL HERE**

**Drug Chamber**

Discard unit if foil strip is damaged. Peel foil strip only when ready for use. Visually inspect drug prior to reconstitution.

See package insert for complete directions for reconstitution and administration.

LD-336-1 X27-001-485

# Cefazolin for Injection USP and Dextrose Injection USP

# 2g\*

REF 3105-11

NDC 0264-3105-11

DUPLEX® CONTAINER

50 mL

Use only after mixing contents of both chambers.

For IV Use Only      Iso-osmotic      Single Dose      Sterile/Nonpyrogenic

\* Contains Cefazolin Sodium USP equivalent to 2 g cefazolin.

**Reconstitution:** Hold container with set port in a downward direction and fold the diluent chamber just below the solution meniscus. To activate seal, squeeze folded diluent chamber until seal between diluent and drug chamber opens, releasing diluent into drug chamber. Agitate the reconstituted solution until the drug powder is completely dissolved. Fold the container a second time and squeeze until seal between drug chamber and set port opens.

After reconstitution each 50 mL single dose unit contains: Cefazolin for Injection USP (equivalent to 2 g cefazolin) with approx. 1.5 g (3.0% w/v) Hydrus Dextrose USP in Water for Injection USP. Sodium content is 48 mg/g of cefazolin sodium. Approximate osmolality: 290 mOsm ol/kg

**Prior to Reconstitution:** Store at 20-25°C (68-77°F). Excursions permitted to 15-30°C (59-86°F). [See USP Controlled Room Temperature.] Use only if container and seals are intact. Do not peel foil strip until ready for use. After foil strip removal, product must be used within 7 days, but not beyond the labeled expiration date. Protect from light after removal of foil strip.

**After Reconstitution:** Use only if prepared solution is clear and free from particulate matter. Use within 24 hours if stored at room temperature or within 7 days if stored under refrigeration. Do not use in a series connection. Do not introduce additives into this container. Prior to administration check for minute leaks by squeezing container firmly. If leaks are found, discard container and solution as sterility may be impaired. Do not freeze.

**Not made with natural rubber latex, PVC or DEHP.**

Rx only

**B | BRAUN**

B. Braun Medical Inc.  
Bethlehem, PA 18018-3524

LD-200-4  
Y37-002-542

EXP

LOT



NDC No. (01)10302643105119

Prepared in USA. API from USA and Italy.

PEEL HERE



## Drug Chamber

Discard unit if foil strip is damaged. Peel foil strip only when ready for use. Visually inspect drug prior to reconstitution.

See package insert for complete directions for reconstitution and administration.

LD-336-1 X27-001-485

### CEFAZOLIN SODIUM

cefazolin sodium solution

#### Product Information

<b>Product Type</b>	HUMAN PRESCRIPTION DRUG	<b>Item Code (Source)</b>	NDC:0264-3103
<b>Route of Administration</b>	INTRAVENOUS		

#### Active Ingredient/Active Moiety

Ingredient Name	Basis of Strength	Strength
<b>CEFAZOLIN SODIUM</b> (UNII: P380M0454Z) (CEFAZOLIN - UNII:IHS69L0Y4T)	CEFAZOLIN	1 g in 50 mL

#### Inactive Ingredients

Ingredient Name	Strength
<b>DEXTROSE MONOHYDRATE</b> (UNII: LX22YL083G)	2 g in 50 mL
<b>WATER</b> (UNII: 059QF0KO0R)	

#### Packaging

#	Item Code	Package Description	Marketing Start Date	Marketing End Date
1	NDC:0264-3103-11	24 in 1 CASE	07/27/2000	
1		50 mL in 1 CONTAINER; Type 0: Not a Combination Product		

## Marketing Information

Marketing Category	Application Number or Monograph Citation	Marketing Start Date	Marketing End Date
NDA	NDA050779	07/27/2000	

## CEFAZOLIN SODIUM

cefazolin sodium solution

### Product Information

Product Type	HUMAN PRESCRIPTION DRUG	Item Code (Source)	NDC:0264-3105
Route of Administration	INTRAVENOUS		

### Active Ingredient/Active Moiety

Ingredient Name	Basis of Strength	Strength
CEFAZOLIN SODIUM (UNII: P380M0454Z) (CEFAZOLIN - UNII:IHS69L0Y4T)	CEFAZOLIN	2 g in 50 mL

### Inactive Ingredients

Ingredient Name	Strength
DEXTROSE MONOHYDRATE (UNII: LX22YL083G)	1.5 g in 50 mL
WATER (UNII: 059QF0KO0R)	

### Packaging

#	Item Code	Package Description	Marketing Start Date	Marketing End Date
1	NDC:0264-3105-11	24 in 1 CASE	01/13/2012	
1		50 mL in 1 CONTAINER; Type 0: Not a Combination Product		

## Marketing Information

Marketing Category	Application Number or Monograph Citation	Marketing Start Date	Marketing End Date
NDA	NDA050779	01/13/2012	

**Labeler** - B. Braun Medical Inc. (002397347)

Revised: 7/2021

B. Braun Medical Inc.